

# PH220 Lectures on Physics

R. Todd Lines  
Brigham Young University-Idaho

Created in Scientific Workplace™

Copyright ©2014 by Author

# Preface

## Preface

This document contains my lecture notes for the third semester of introductory physics. What actually happens in the class room may be very different. I use an active approach with a classroom response system. But if I were to lecture the whole time, this is what I would plan to say. These notes also serve as a review of what we did in class and (and likely more).

## Forward

## Acknowledgments

*BYU-I*

*R. Todd Lines.*





# Contents

<b>Preface</b>	<b>iii</b>
<b>Preface</b>	<b>iii</b>
<b>Forward</b>	<b>iii</b>
<b>Acknowledgments</b>	<b>iii</b>
<b>0 Introduction: Motion and Environment<sup>1</sup></b>	<b>1</b>
<b>1 Charge</b>	<b>5</b>
<b>What is Charge</b>	<b>6</b>
<b>Model for Charge</b>	<b>13</b>
<b>Insulators and Conductors</b>	<b>14</b>
<b>Conduction in solids</b>	<b>17</b>
<b>Note on drawing charge diagrams</b>	<b>23</b>
<b>2 Coulomb's Law and Lines of Force</b>	<b>25</b>
<b>Coulomb's Law</b>	<b>25</b>
<b>Direction of the force</b>	<b>29</b>
<b>More than two charges</b>	<b>30</b>
<b>Fields</b>	<b>36</b>
<b>Field Lines</b>	<b>40</b>

---

<sup>1</sup> Note to editors: Yes this is a chapter number 0. I know this is not customary, but zero is a perfectly good number. There is no requirement that a book start with chapter 0. So please don't change this. I want the new material for the course to start with chapter 1. So don't undo hundreds of years of mathematical debate and negate zero. It's a nice number.

	On-Line fun	43
<b>3</b>	<b>Electric Fields of Standard Charge Configurations Part I</b>	<b>45</b>
	Standard Charge Configurations	45
	Point Charges	45
	Combinations of many charges	55
	On-Line Fun	58
<b>4</b>	<b>Electric Fields of Standard Charge Configurations Part II</b>	<b>59</b>
	Fields from Continuous Charge Distributions	59
<b>5</b>	<b>Motion of Charged Particles in Electric Fields</b>	<b>69</b>
	Sheet of Charge	69
	Constant electric fields	74
	Particle motion in a uniform field	77
	Non uniform fields	84
<b>6</b>	<b>Dipole motion, Symmetry</b>	<b>87</b>
	Dipole motion in an electromagnetic field	87
	Symmetry	95
<b>7</b>	<b>Electric Flux</b>	<b>101</b>
	The Idea of Flux	101
<b>8</b>	<b>Gauss' Law and its Applications</b>	<b>115</b>
	Gauss' Law	115
	Examples of Gauss' Law	119
	Derivation of Gauss' Law	126

<b>9</b>	<b>Conductors in Equilibrium, Electric Potentials</b>	<b>131</b>
	Conductors in Equilibrium	131
	Electrical Work and Energy	138
<b>10</b>	<b>Electric potential Energy</b>	<b>143</b>
	Point charge potential energy	143
	Dipole potential energy	151
	Shooting $\alpha$ -particles	153
<b>11</b>	<b>Electric Potentials</b>	<b>155</b>
	Electric Potential	155
	Example, potential of a capacitor	158
	Electron Volt	162
<b>12</b>	<b>Electric potential of charges and groups of charges</b>	<b>167</b>
	Point charge potential	167
	Potential of groups of charges	175
<b>13</b>	<b>Potential and Field</b>	<b>181</b>
	Connecting potential and field	181
	Sources of electric potential	186
	Electrochemical separation of charge	187
	Batteries and emf	187
<b>14</b>	<b>Calculating fields from potentials</b>	<b>195</b>
	Finding electric field from the potential	195
	Geometry of field and potential	199
	Conductors in equilibrium again	203

**15 Capacitance 209**

Capacitance and capacitors 209

Combinations of Capacitors 216

**16 Dielectrics and Current 221**

Energy stored in a capacitor 221

Dielectrics and capacitors 224

Induced Charge 227

Electric current 228

**17 Current, Resistance, and Electric Fields 235**

Current and resistance 235

Current density 241

Conservation of current 243

**18 Resistance 247**

Conductivity and resistivity 247

**19 Ohm's law 251**

Electronic symbols 255

**20 Kirchoff's Rules for Direct Current Circuits 259**

EMF 259

Conservation of Charge (Reprise) and Conservation of Energy 259

Combinations in series and parallel 261

Series Resistances 265

Examples 266

Power in resistors 268

<b>21 RC Circuits</b>	<b>271</b>
Circuits made from Resistors	273
Resistors and Capacitors Together	276
Meters	282
Household Circuits	285
<b>22 Magnetism</b>	<b>287</b>
Discovery of Magnetic Field	290
<b>23 Current loops</b>	<b>299</b>
Magnetic field of a current	299
Magnetic dipoles	305
<b>24 Ampere's law, and Forces on Charges</b>	<b>311</b>
Ampere's Law	311
Magnetic Force on a moving charge	319
Motion of a charged particle in a $B$ -Field	321
Hall Effect	328
<b>25 Magnetic forces on wires</b>	<b>331</b>
Magnetic forces on Current-Carrying wires	331
Torque on a Current Loop	333
<b>26 Permanent Magnets, Induction</b>	<b>341</b>
Finally, why magnets work	341
Back to the Earth	352
Induced currents	353
<b>27 Induction</b>	<b>357</b>

x Contents

Motional emf 357

Eddy Currents 360

Magnetic flux 361

**28 Faraday and Lenz 367**

Fundamental Concepts in the Lecture 368

Lenz 368

Faraday 369

Return to Lenz's law 370

Pulling a loop from a magnetic field. 371

**29 Induced Fields 375**

Generators 375

Transformers (not the movie) 380

Induced Electric Fields 381

Relationship between induced fields 384

Electromagnetic waves 386

**30 Inductors 389**

Self Inductance 389

Energy in a Magnetic Field 391

Return to Non-Conservative Fields 403

Magnetic Field Energy in Circuits 411

Mutual Induction 412

**31 The Electromagnetic field 417**

Relative motion and field theory 417

Field Laws 429

<b>32</b>	<b>Field Equations and Waves in the Field</b>	<b>433</b>
	Displacement Current	433
	Maxwell Equations	439
<b>33</b>	<b>Electromagnetic waves</b>	<b>441</b>
	Turning the Maxwell Equations into Differential Equations	441
	Wave equation for plane waves	446
	Properties of EM waves	448
	The Electromagnetic Spectrum	454
<b>34</b>	<b>Polarization</b>	<b>459</b>
	Polarization of Light Waves	459
	Making alternating current	468
<b>35</b>	<b>Alternating Currents and Potentials</b>	<b>471</b>
	Instantaneous current and potential	471
	Phasor Addition	474
<b>36</b>	<b>AC circuits with Capacitors and Resistors</b>	<b>479</b>
	AC Circuits and Capacitors	479
<b>37</b>	<b>Inductive AC Circuits, and the LRC AC circuit</b>	<b>489</b>
	AC Circuits and Inductors	489
	RLC Series circuits	491
	Power in an AC Circuit	499
	Retrospective	503
	PH121 or Dynamics Right Hand Rules	505
	PH223 Right Hand Rules	507

xii Contents

**Some Helpful Integrals 511**



# 0 Introduction: Motion and Environment<sup>2</sup>

If you are taking PH220 you should have already taken PH121 or an equivalent class. In PH121, you learned about how things move. You learned about forces and how force relates to acceleration

$$\vec{\mathbf{F}} = m \vec{\mathbf{a}}$$

The force,  $\vec{\mathbf{F}}$ , is how hard you push or pull. This push or pull changes the motion of the object, represented by its mass,  $m$ . The change in motion is represented by its acceleration,  $\vec{\mathbf{a}}$ . Notice that both  $\vec{\mathbf{F}}$  and  $\vec{\mathbf{a}}$  are vectors. We will need all that you learned about vectors in PH121.

Since physics is the study of how things move, we are going to study the motion of objects again in this class. But in this class we will learn about new sources of force, that is, new ways to push or pull something.

Really these new sources of force are not entirely new. You have heard of them and probably experienced them. They are electrical charge and magnetism. You have probably had a sock stick from you after pulling it out of a dryer, and you have probably had a magnet that sticks to your refrigerator. So although these new sources of force are new to our study of physics, they are somewhat familiar in every day lives.

To get us started this semester I want to review a particular force, the force due to gravity. Think of most of our experience with gravity. We have an object moving near the Earth. There is a force acting on the object, and that force is because of Earth's gravity.

We can think of the Earth as creating an environment in which the object moves, feeling the gravitational force.

---

<sup>2</sup> Note to editors: Yes this is a chapter number 0. I know this is not customary, but zero is a perfectly good number. There is no requirement that a book start with chapter 0. So please don't change this. I want the new material for the course to start with chapter 1. So don't undo hundreds of years of mathematical debate and negate zero. It's a nice number.

## 2 Chapter 0 Introduction: Motion and Environment<sup>3</sup>

Think of a ball falling. We considered this as an environment of constant acceleration. In this environment, the ball feels a force proportional to their mass

$$\vec{F} = m \vec{g}$$

where  $g = 9.81 \frac{m}{s}$  is the acceleration due to gravity. This is true anywhere near the Earth's surface. We could draw this situation as follows:

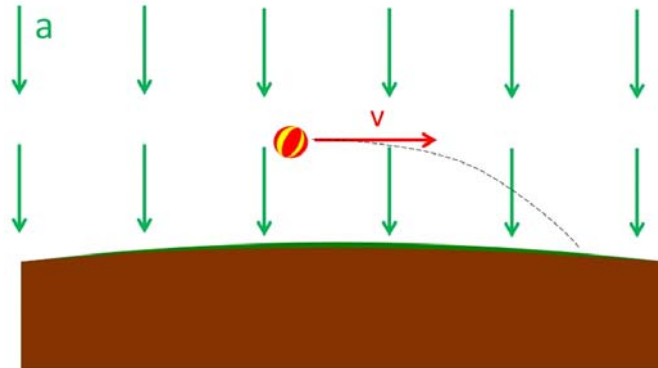

where the environment for constant acceleration is drawn as a series of arrows in the acceleration direction (downward toward the center of the Earth). Anywhere the ball goes the environment is the same. So we draw arrows all around the ball to show that the whole environment around the ball is the same.

This environment is caused by the Earth being there. If the Earth suddenly disappeared, then the acceleration would just as suddenly go to zero. So we can say that the Earth creates this constant acceleration environment.

Notice that there are two objects involved, the ball and the Earth. Also notice that one object creates an environment that the other object moves in. In our case, the Earth created the environment and the ball moved through the environment. This situation will recur many times in our course, so let's give the objects these names, the Earth as the "Environmental object", and the ball as the "mover."

Now you might object, because the force of gravity requires both objects, so how can we be sure that we have chosen the right objects to be the environmental object and the mover? Well, you remember that this depends on which reference frame we use to view the situation. Since we are sitting on the Earth, it is most common to see the Earth as sitting still and the ball going by. Then the Earth is the environmental object and the ball is the mover. But if we were a fly sitting on the ball, we might see the ball as the environmental object and the Earth as the mover!

Both views are equally valid! It is easier to view the Earth as the environmental object, though, and we will find that in our problems this semester it is important to look at our problems to see which reference frame will let us get a solution easier.

The important thing here is to view the situation as an environment and it's environmental object with a mover object moving through the environment.



# 1 Charge

In the past two courses our goal was to learn how things move. We learned in PH121 and/or ME204 how objects move. We learned all about Newton's laws which are our description of how things move. If you have taken PH 123 you learned how groups of things move, like water molecules in waves or air molecules in the room. We also learned about how light moves, but there was a mystery there that we need to illuminate this semester. That is, we really did not deal with the mechanics of how you make light. By the time we are done this semester you will know how this works!

But most of the semester we will learn about the cause of a particular force, the force created by electric charge. You have probably felt this force when you put on a sweater that has a static charge. You may have found a stray sock sticking to your sweater. (hopefully before you wore it to class). This semester we will learn about this force and the magnetic force. Then, of course, we can apply these new forces to our dynamics problems from PH121 to see things move in new ways. We start, then, with the source of these new forces. Charge

## Fundamental Concepts

- There is a property of matter called "charge."
- There seem to be two types of charges, called "positive" and "negative."
- We have a model for how charge acts. The model tells us there are two types of charge, and that charges of similar type repel and charges of different type attract.
- We call the types of charge "positive" and "negative"
- In metals, the valence electrons are free to move around. We call materials where the charges move "conductors."
- Materials where the valence electrons cannot move are called "insulators."
- In insulators, the atoms can "polarize."

## What is Charge

But what is charge? How do we know there are such things as charged particles?

That is the subject we will take up next. Then we will study the motion and actions of these charged particles. Finally we will show that the fields made by charged particles can act as a medium for waves, and that there is good evidence that those waves exist.

## Evidence of Charge

Let's start with something we all know. Let's rub a balloon in someone's hair. If we do this we will find that the balloon sticks to the wall. Why?

Balloon and 2 by 4 demo

Balloon on wall demo

Comb and bits of paper demo

Glass and Rubber Rod Demo

We say the balloon and comb have become *charged*. What does this mean? We will have to investigate this more as we learn more about how matter is structured, but for now let's assume charge is some property that provides this phenomena we have observed with the balloon (i.e. it sticks to the wall). Now lets try rubbing other things.

We could rub two rubber or plastic rods.

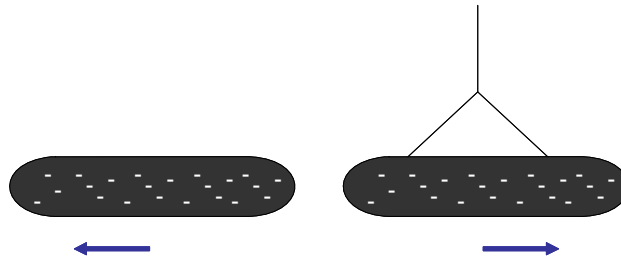

Two charged rubber rods are placed close together. The rods repel each other. and we could also rub two glass rods

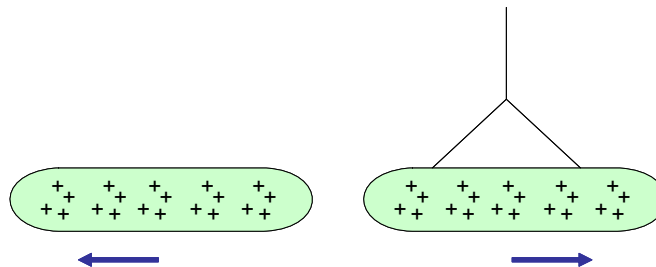

Notice that in each case we have created a force between the two rods. The rods now repel each other.

Now let's try a glass and a rubber rod

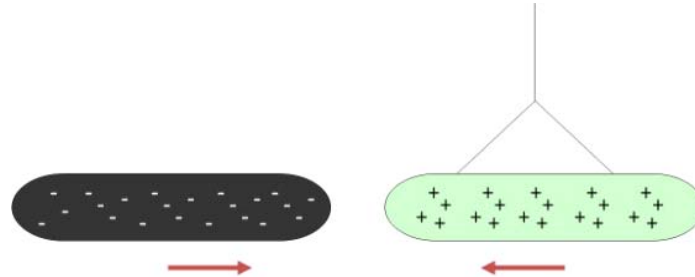

Now the two different rods attract each other.

Notice that in our demo, rods that are the same repel and rods that are different attract. We make the intellectual leap that the different rods have different charges. So we are really saying:

1. There are two types of charge.
2. Charges that are the same repel one another and charges that are different attract one another.
3. Friction seems to produce charge, but you have to rub the right materials together.

We will call the rubber or plastic rod charges *negative* and the glass rod charges *positive* but the choice is arbitrary. Ben Franklin is credited with making the choice of names. He really did not know much about charge, so he just picked two names (we will see that in some ways his choice was somewhat unfortunate, but hey, he was an early researcher who helped us understand much about charge, so we will give him a break!).

## Types of Charge

We now have reason to believe that there are at least two types of charge, one for rubber and one for glass. But are there more?

No-rubbing demo

Let's start by introducing a new object, only this time we won't rub it with anything.

Now this is strange. The new item is attracted to both rods! What is going on? Have we discovered a new type of charge, one that attracts the other two types we have found?

Question 223.19.4 Maybe, but maybe the explanation of this phenomena is a little different. To understand this, let's consider how charge moves around.

Question 223.19.5

## Movement of Charge

One of the strange things about charge is that it is *quantized*. We learned this word in when we found that only certain standing waves could be formed between boundaries. We are using this word in a similar way now. It means that charge has a smallest unit, and that it only comes in whole number multiples of that unit. Charge comes in a basic amount that can't be divided into smaller amounts. So like our standing wave frequencies, only certain amounts are possible. As far as we know, the smallest amount of charge possible is the electron charge.<sup>4</sup> This charge we will call negative. We say that the electron is the principle charge carrier for negative charge. This fundamental unit of charge was found to be about

$$e = 1.60219 \times 10^{-19} \text{ C} \quad (1.1)$$

where the C stands for *Coulomb*, the *SI* unit of charge.

Any larger charge must be a multiple of this fundamental charge

$$Q = n \times e \quad (1.2)$$

The proton is the principle charge carrier for positive charge. From chemistry, you know protons are located in the nucleus of an atom, along with the neutron. In the Bohr model of the atom, the nucleus is surrounded by a cloud of electrons. The proton has the same amount charge as the electron ( $e$ ), but is opposite in sign.

In a gram of mater, there are many, many, units of charge. There are about  $5.0125 \times 10^{22}$  carbon atoms in one gram of carbon. Each carbon atom has twelve protons and about twelve electrons. That is a lot of charge! But notice that the net charge is zero (or very close to it!). It is common for most mater to have zero net charge.

As far as we know, charge is always conserved. We can create charge, but only in plus or minus pairs, so the net charge does not change. We can destroy charge, but we end up destroying both a positive and a negative charge at the same time. The net charge in the universe does not seem to change much. So when something becomes charged, we expect to find that the charge has come from another object.

---

<sup>4</sup> I am not counting quarks here, which have a charge of  $\frac{1}{3}$  or  $\frac{2}{3}$  of the basic electron charge. But still,  $\frac{1}{3}$  of the basic electron charge seems to be a real fundamental unit.



Lets go back to our rubber rod and glass rod demo. We rubbed the rod that was in our hand, but where did the charge come from? We believe that we are moving charge carriers (usually electrons) from one object to another, stripping them from their atoms. This happens when we use friction (rubbing) to charge the rods.

But what about our object that we did not rub, or our paper (we did not rub the bits of paper). We believe that charge can move, that is why scientists looked for and found charge carriers. Even in an atom, if I bring a charged object near the atom then the negative charge carriers (electrons) will experience a force directed away from the charged object, and the positively charged nucleus will experience a force pulling toward the charge object

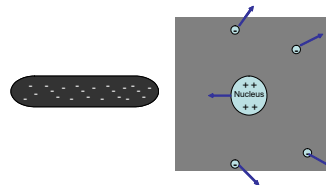

Notice that the electrons and the nucleus will *attract* each other, so the atom won't split apart. But it will become positively charged on one side because there are more positive charge carriers on that side. It will become more negatively charged on the other side, because there are more negative charge carriers on that side. We could draw the atom like this (figure 1.1)The force due to charge depends on how far away the charges are

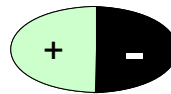
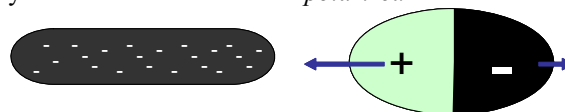

Figure 1.1.Polarized Atom

from each other. The attractive force between the positively charged side of the atom and the negative rod will have a stronger force than the negatively charged side of the atom and negatively charged rod will experience because the negative side is farther away. We will say that the atom has become *polarized*.



The positive side will experience an attractive force. The negative side will experience a repelling force. The net force due to the charge will be an attractive force. The atom will be accelerated toward the rod! We have seen something like this before. Remember an object in a fluid experiences a downward pressure force on the top, and an upward

pressure force on the bottom. The pressure force is larger on the bottom, so there is an upward Buoyant force. The case with our polarized atom is very similar. We have a net electrical attractive force.

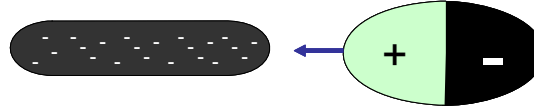

Now suppose we have lots of atoms (like our uncharged object or our bits of paper). Will they be attracted to the rod? Yes!

How about if we use a glass rod?

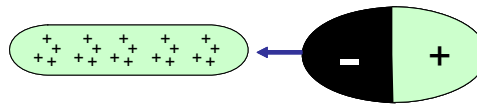

Everything is the same, only we switch the signs. The glass rod is positively charged. It will attract the electrons, and repel the nucleus. The atom becomes charged. The net force is attractive (positive rod and closer negative side of the atom)

We sometimes call the separation of charge in an insulator *polarization*.

## Flow of Charge

Salt Shaker Demo

Let's start by introducing a new object, a salt shaker (my salt shaker is glass with a metal top). We will rub the salt shaker and see if it gets charged by placing it next to our charged rods.

Question 223.19.6

Now this is strange. We rubbed the object, but it was attracted to both rods as if there were no charge. We know glass can be charged. What is the problem?

Metal Demo

It turns out that some materials allow charge carriers to flow through them. Our experience with the lighting in our house might suggest that metals will do this. Let's try some other metal objects and see what we find.

It seems that the atoms are not maintaining a charge separation in these metal atoms! Some materials allow charge carriers to move through them. Usually these materials are metals, but most materials will allow some charge to go through them-even you-which is what is happening in this case. I charge the rod, but the charge leaves through my body. Other materials resist the flow of charge. Materials that allow charge to flow are called *conductors*. Materials that resist the flow of charge are called *insulators*.

## Charging by Induction

Knowing that charge carriers can flow through a material, we can think of a way to charge a conductor. Let's suspend a conducting rod.

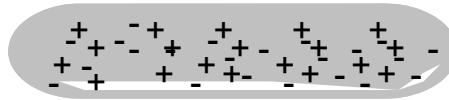

It is not initially "charged" meaning that it has the same number of positive charges and negative charges, and they are evenly mixed together. I will bring a charged rod next to it.



but let's attach a wire to the other end of the rod to allow the charge to flow away from our conducting rod. We will connect the rod to the ground (in this case, to a water pipe) because the ground seems to be able to accept large amounts of charge carriers. So the charge carriers will flow to the ground.



Figure 1.2.

(The strange little triangular striped thing is the electronics sign for a connection to the ground)

Now let's disconnect the wire from the rod. Is there a net charge on the conducting rod?

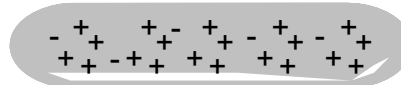

The answer is yes, because we now have more positive charges in the conducting rod than we have negative charges, so the net charge is positive.

### Charging by Conduction

Suppose instead, I perform the same experiment, but I touch the rods. Now charge carriers can flow. Starting with an uncharged conductor,

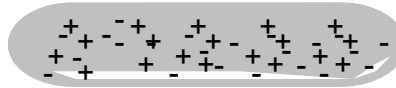

I again bring in a charged rod. Again the charges separate in our conducting rod.



Then we touch the two rods. The excess charge on our charged rod flows to the conductor. Since in our drawing, the excess charge is negative, then some of the positive charge on the conductor is neutralized.

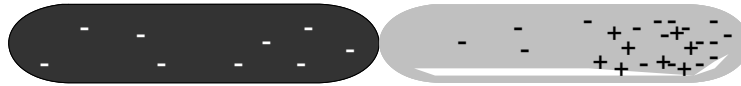

Take home lab assignment (using Scotch Brand Tape)

When we separate the rods, our conducting rod will have an excess of negative charge.

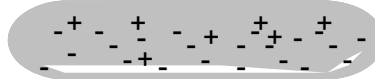

Notice that there is something different in our study of this new force. In the past, it was easy to tell which object was creating the environment and which was the mover. The Earth, being so much larger than normal objects, was the environmental object creating the gravitational acceleration that balls and cars and people move it. Then the balls and cars and people were the movers. Generally the thing causing the force, the environmental object, was much bigger than the mover. That is not true in our charge experiments so far. The rods are about the same size. So which is the environmental object and which is the mover? We will have to pick one to be our environmental object, and the other to be our mover. Sometimes the context of the problem helps. If the problem you are solving asks for the motion or the force on the rod on the right side of the diagram, then it is the mover and the rod on the left is the environmental object. If one charge is much larger than the other, we might be justified in calling this large charge the environmental object and a smaller charge near the big charge would be the

mover.

## Model for Charge

- Question 223.20.1 A model is a mental explanation for something. We are looking for a model, or an explanation of how charge acts.
- Question 223.20.2 Let's summarize what we tried to learn last time:
- Question 223.20.3
- Question 223.20.4

Model for Charge
Frictional forces can add or remove charge from an object
There are two, and only two kinds of charge
Two objects with the same kind of charge repel each other
To objects with different kinds of charge attract each other
The force between two charged objects is long ranged
The force between two charged objects decreases with distance
Uncharged objects have an equal mix of both kinds of charge
There are two types of materials, conductors (in which charges can move) and insulators (in which charges are fixed in place)
Charge can be transferred from one object to another by contact between the two objects

A serious shortcoming of this model is that it does not tell us what charge is. This is a shortcoming we will have to live with. We don't know what charge is any more than we can say exactly what mass or energy are. Charge is fundamental, as far as we can tell. We can't find a way to change charge into something else to change something else into charge. For fundamental particles (like protons and electrons) either a particle has charge, or it does not.

## Conservation of charge

In some ways, this is really great! We have a new quantity that does not ever change. We can say that charge is conserved in the universe. Like energy, we can move charge around, but we don't create or destroy it<sup>5</sup>. When we rubbed the plastic rods with rabbit fur or wool, we were removing charge that was already there in the atoms of the fur. If you take PH279 you might find that there are some caveats to this rule. We can make positron and electron pairs from high energy gamma rays. But when we do this we

---

<sup>5</sup> There is really a way to create charge, but you have to create both a positive and a negative charge together, so the net charge in the universe never changes.

must always make a pair; one positive, and one negative. So the net charge remains unaffected.

## Insulators and Conductors

Question 223.20.5

Let's return to charges and atoms. We have an intuitive feeling for what is a conductor and what is an insulator, but let's see why conductors act the way they do.

## Potential Diagrams for Molecules

Back in high school or in a collage chemistry class you learned that electrons move around an atom.

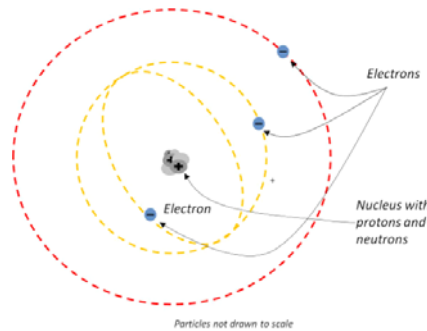

In the figure there are two energy states represented. You may even remember the names of these energy states. The orange-yellow lines show one "orbital distance" for the electrons near the nucleus. The red line shows another electron at a larger orbital distance. The inner orbital is a  $1s$  state and the outer orbital is a  $2s$  state. If these were satellites orbiting the earth, you would recognize that the two orbits have different amounts of potential energy. This is also true for electrons in orbitals. If we plot the potential energy for each state we get something that looks like this

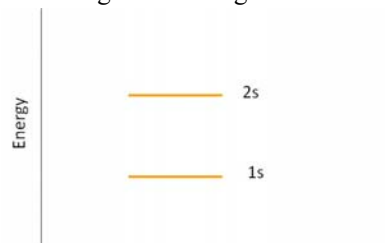

(Schematic)

You can think of this as potential energy "shelves" where we can put electrons. If you

were a advanced high school student, you learned that on the first two shelves you can only fit two electrons each. The higher shelves can take six, and so forth. But that won't concern us in this class.

### Building a solid

Note also that so far I have really only talked about single atoms. What happens when we bind atoms together?

Let's take two identical atoms. When they are far apart, they act as independent systems. But when they get closer, they start acting like one quantum mechanical system. What does that mean for the electrons in the atoms?

Electrons are funny things. They won't occupy the exactly the same energy state. I can only have two electrons in a  $1s$  state, but as I bring two atoms near each other I will have four! How does the compound solve this problem? The energy "shelves" split into more shelves. As the atoms get closer, we see something like this

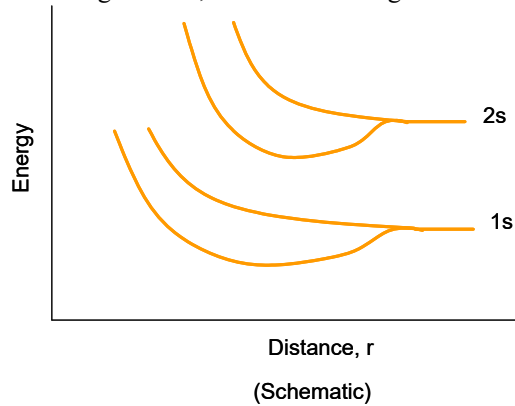

At some distance,  $r$ , the states split. So each electron is now in a different state. Suppose we bring 5 atoms together.

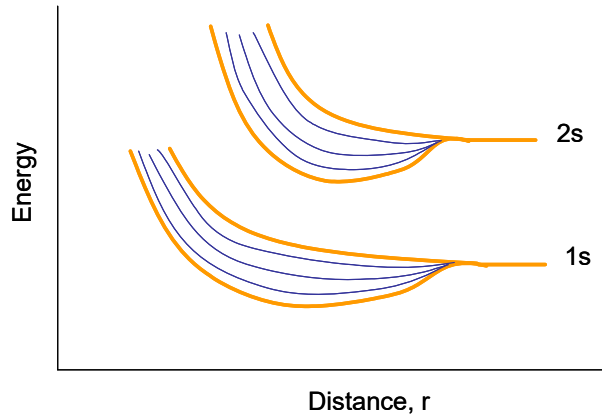

(Schematic)

I get additional splitting of states. Now I have five different 1s states, enough for 5 atoms worth of 1s electrons. But solids have more than five atoms. Let's bring many atoms together.

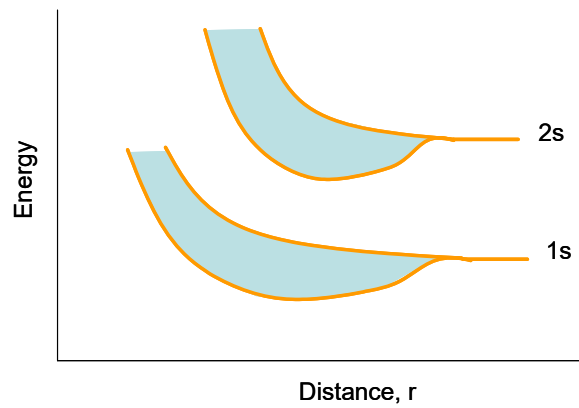

(Schematic)

Now there are so many states that we just have a blue blur in between the original two split states. We have created a nearly continuous set of states in two bands. Each electron has a different energy, but those energy differences might be tiny fractions of a Joule. The former two states have almost become continuous bands of allowed energy states.

The atoms won't allow themselves to be too close. They will reach an equilibrium distance,  $r_o$  where they will want to stay.



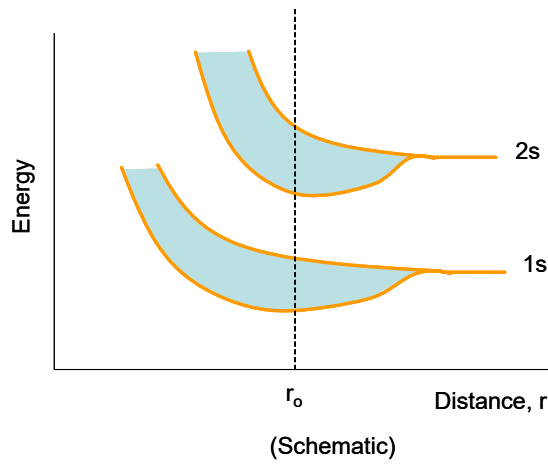

Since this is where the atoms usually are. We will not draw the whole diagram anymore. We will instead just draw bands at  $r_0$ . (along the dotted line). Here is an example.

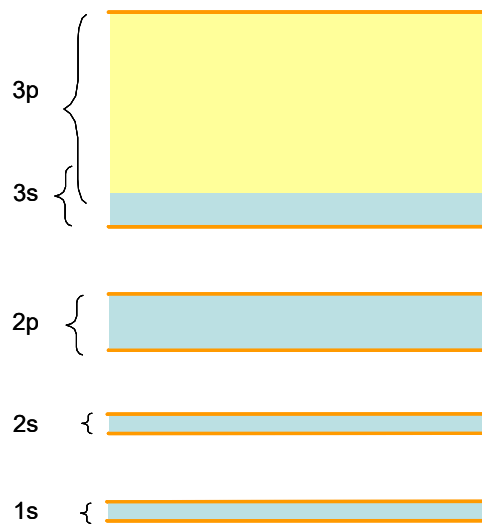

This means we have *bands* of energies that are allowed, that electrons can use, and *gaps* of energy where no electron can exist.

### Conduction in solids

Notice that in our last picture, the 3s and 3p bands have grown so much that they overlap. The situation with solids is complicated. Notice also that the lower states are

blue. We will let blue mean that they are filled with electrons taking up every available energy state. The upper states are only partially filled. Yellow will mean the energy states are empty. We will call the highest completely filled band the *valance band* and the next higher empty band the *conduction band*.

We have three different conditions possible.

### metals

In a metal, the highest occupied band is only partially filled

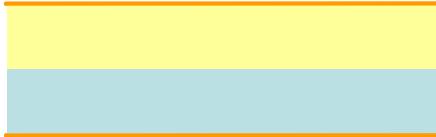

the electrons in this band require only very little energy to jump to the next state up since they are in the same band and the allowed energies are very closely spaced. Remember that movement requires energy. So if I connect a battery to provide energy, the electrons must be allowed to gain the extra energy, kinetic energy in this case, or they will not move. But in the case of a metal, there are easily accessible energy states, and the electrons flow through the metal.

We can say that the outer electrons are shared by all the atoms of the entire metal, so the electrons are easy to move for metals.

### Insulators

A second condition is to have a full valance band and an empty conduction band. The bands are separated by an energy gap of energy  $E_g$ .

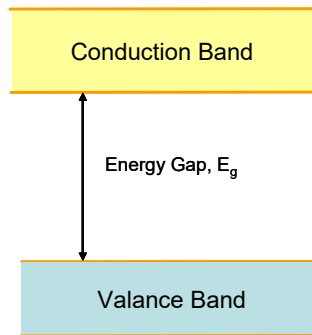

In this case, it would take a whopping big battery to make the electrons move. the battery would have to supply all of the gap energy plus a little more to get the electron to move. If we do connect a very large battery, say, 33000 V, then we can get electrons to jump the gap to a higher energy “shelf.” But high voltages are not normal conditions, so this is not usually the case. A material that has a large energy gap between it’s valance band and an empty conduction band is called an insulator.

A mental picture for this might be as shown in the next figure.

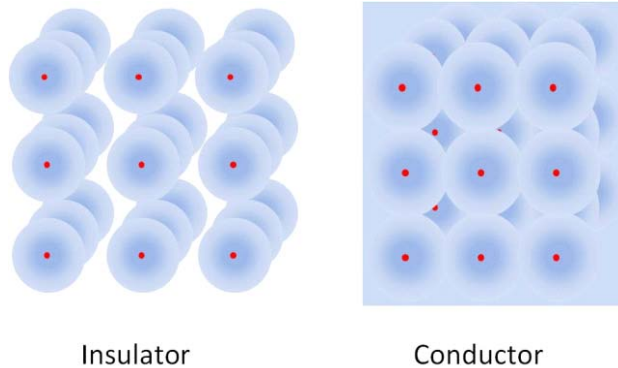

The insulator atoms keep their valence electrons bound to the nuclei of the atoms. But for a conductor, the valence electrons are free to travel from atom to atom.

Question 223.20.6

Question 223.20.7

In an isolated conductor, normally the charge is balanced, so the electrons may move but generally they stay near a nucleus. But if a conductor has extra electrons, the electrons that can move will move because they repel each other. So any extra charge will be on the surface of the conductor.

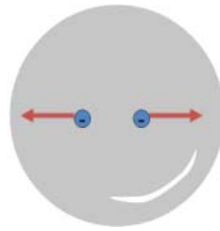

This happens very quickly, generally we do find the extra charge distributed on the outside of a conductor.

## Semiconductors

The third choice is that there is a band gap, but the band gap is small. In this case, some electrons will gain enough thermal energy to cross the gap. Then these electrons will be in the conduction band. Devices that work this way are called semiconductors. We won't deal with semiconductors much in this class, but you probably used many of them in ME210. Diodes, and transistors are made from semiconductors.

## Charging and discharging conductors

Conductors can't usually be charged by rubbing. The electrons in the conductor may move when rubbed, but then they are free to move around in the conductor, so they don't leave. But if we rub an insulator, the electrons are not free to travel in the insulator material, so we can break them free. Once this happens, we can take our charged insulator and place it in contact with a conductor. The charge can flow from the insulator to the conductor (and arrange itself on the conductor surface). Once the charge has moved to the exterior, it will reach what we call *electrostatic equilibrium*. All of the repelling electrical forces are in balance, so the charges come to rest with respect to the conductor.

Question 223.20.8

We can remove the extra charge by creating a path for the charge to follow. Consider charging a balloon by rubbing it on your hair. Then you connect a wire to the balloon that is also connected to a metal water pipe. The charge can flow through the metal conducting wire. If there is a large body that can attract extra charge, the charge will flow. The Earth is such a large body that can attract the extra charge. The charge will flow through the wire and pipe and go into the ground.

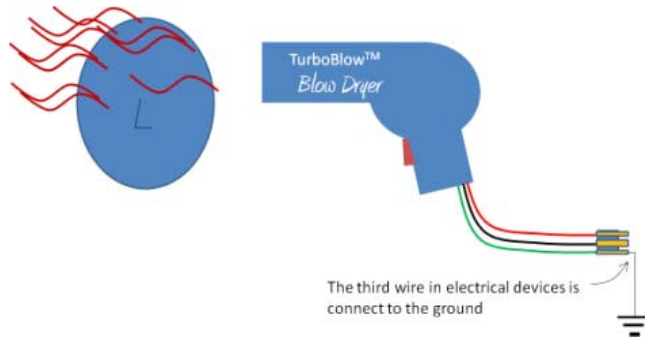

You may have heard of electrical grounds. This literally means tying your device to the Earth through a wire. Since you are made mostly of water that contains positive ions, you are also a conductor. So if we touch a charged object, we will most likely discharge the object. This is also why we must be careful with charge. Large amounts of charge flowing through us leads to death or injury.

If an object is *grounded*, it cannot build up extra charge. This is good for appliances and houses, and people.

We talked last time about insulator atoms being polarized.

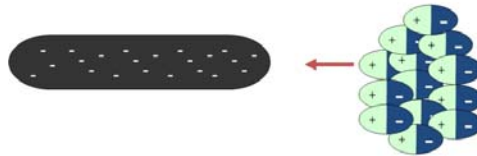

Remember that for each atom the electrons are displaced relative to the nucleus.

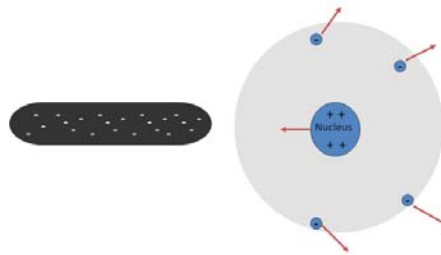

We can define a *center of charge* much like we defined a center of mass. In the case in the figure, we can define a negative center of charge and a positive center of charge.

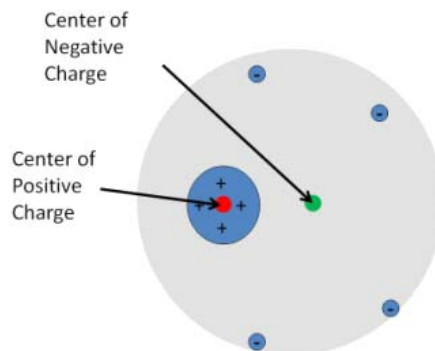

Question 223.20.9

Notice that the negative and positive center of charge are not in the same place when the atom is polarized. We have a name for a pair of positive and negative charges that are separated by a distance, but that are still bound together. We call it an *electric dipole*. Often we just draw the centers of charge joined by a line.

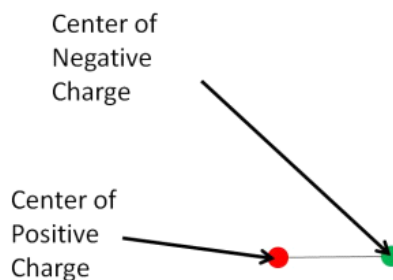

Using this we can explain why humidity affects our last lecture experiments so much. The water molecule has two hydrogen atoms and one oxygen atom. The covalent bond between the oxygen and hydrogen atoms forms when the oxygen “shares” the hydrogen’s electrons. The electrons from the hydrogen atoms spend their time with the oxygen atom making one side of the molecule more positive and the other side more negative.

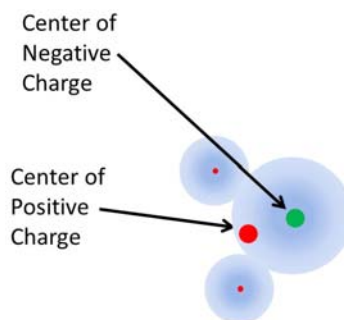

Thus if you have a charged balloon on a humid day, one side of the water molecules in the air will be attracted to the extra charge on the balloon. The extra charge will attach

to the water molecules, and float away with them. This will discharge the balloon.

### Note on drawing charge diagrams

We will have to draw diagrams in our problem solutions. Normally we won't draw atoms, so we will be drawing large objects with or without extra charge. We know that all materials have positive nuclei and negative electrons. When these are balanced, there is an electron for every proton, so if we add up the charges we get zero net charge. These charges don't contribute to net forces because for every attraction there is a repulsion of equal magnitude.

So we won't draw all of these charges, but we should remember they are there. We usually draw a cross section, so here is the cross section of a round, conducting ball.

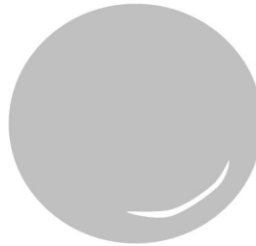

But if we have extra charge, we should draw it. We will just add plus signs or minus signs. We won't draw little circles to show the electrons (we can't draw them to scale, they are phenomenally small). Here is an example of two round objects, one positive and one negative

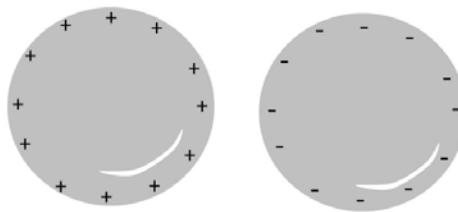

If the objects are not conductors, the extra charge may be spread out. We draw the charge throughout the cross section of the object.

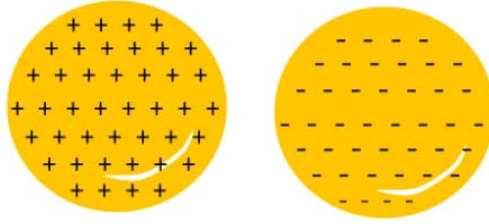

Note that if you transfer charge, from one object to another, you should try to keep the same total number of “+” or “-” signs to show the charge is conserved.

## Basic Equations



# 2 Coulomb's Law and Lines of Force

## Fundamental Concepts

- Our “charge” force is called the Coulomb force, and is given by  $F = k_e \frac{|q_1||q_2|}{r^2}$
- A field is a quantity that has a value (magnitude and direction) at every point in space
- The Coulomb force is caused by an electric field
- We use field lines to give ourselves a mental picture of a field

### Coulomb's Law

My experience so far is that Statics and Dynamics did not teach Newton's law of gravitation so teach it here.

Question  
223.21.0.1

Question  
223.21.0.2

Question  
223.21.0.3

Question  
223.21.0.4

Sometime ago in your Dynamics or PH121 class you learned about gravity. Let's review for a moment.

From our experience we know that more massive things exert a stronger gravitational pull than less massive things. We also have some idea that the farther away an object is, the less the gravitational pull. Newton expressed this as

$$F_g = G \frac{m_1 m_2}{r_{12}^2}$$

where the two masses involved (say, the Earth and you) are  $m_1$  and  $m_2$  and the distance between the two masses is  $r_{12}$  (e.g. the distance from the center of the Earth to the center of you). The constant  $G$  is a constant that puts the force into nice units that are convenient for us to use, like newtons (N). It has a value of

$$G = 6.67428 \times 10^{-11} \frac{\text{N m}^2}{\text{kg}^2}$$

You might ask, how do we know this? The answer is that Newton and others performed experiments. Newton's law of gravitation is empirical, meaning that it came from experiment. Lord Cavendish used a clever device to verify this law. He suspended two masses from a wire. Then he placed two other masses near the suspended masses.

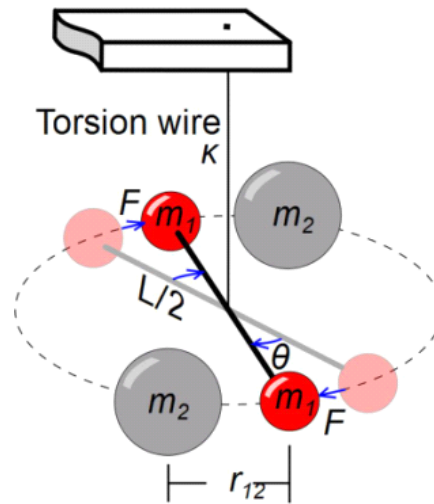

He knew the torsion constant of the wire (how much it resists being twisted). Then by observing how far the suspended masses moved, he could work out the strength of the gravitational force. This is called a torsion balance.

Charles Coulomb thought he could use the same device to measure the strength of the electric force. Here is his experimental design.

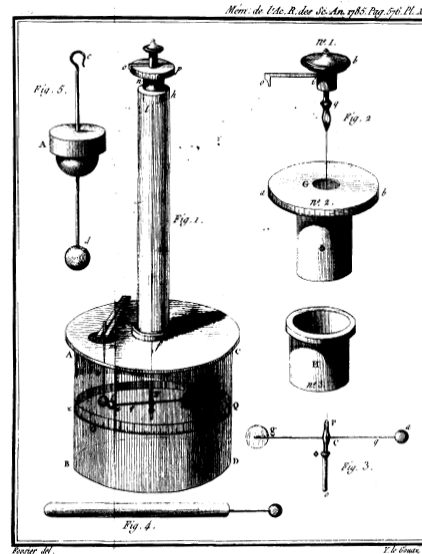

Coulomb's Torsion Balance Apparatus

You can see this is really just a torsion balance. This time objects with equal mass *and equal charge* are suspended on either end of a rod. The rod is hung on a wire. Two other *charges* are brought an equal distance,  $r_{12}$ , from the other charges. Knowing the torsional properties of the wire, the force due to the charges can be found.

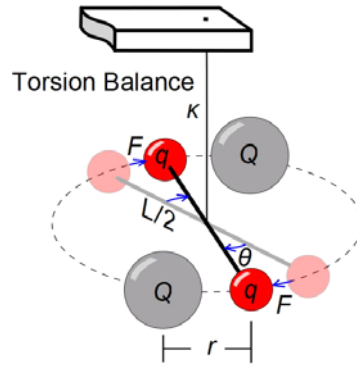

Coulomb determined that the force due to a pair of charges has the following properties:

1. It is directed along a line connecting the two charged particles and is inversely proportional to the distance between their centers
2. It is proportional to the product of the magnitudes of the charges  $|q_1|$  and  $|q_2|$ .
3. It is attractive (the charges accelerate towards each other) if the charges have different signs, and is repulsive (the charges accelerate away from each other) if the charges have the same signs.

We can write this in an equation

$$F = k_e \frac{|q_1| |q_2|}{r_{12}^2} \tag{2.1}$$

Question 223.21.2

Question 223.21.1

Note how much this looks like gravitation! In the denominator, we have the distance,  $r_{12}$ , between the two charged particles' centers. We have two things in the numerator. But now we have  $|q_1|$  and  $|q_2|$  instead of  $m_1$  and  $m_2$ . We have a constant  $k_e$  instead of  $G$ , but the equation is very much like Newton's law of gravitation. That should be comforting, because we know how to use Newton's law of gravitation from PH121 or Dynamics. There is a very big difference, though. Gravitation can only attract masses, The Force due to charges can attract *or* *repel*.

Again there is a constant to fix up the units. Our constant is

$$k_e = 8.9875 \times 10^9 \frac{\text{N m}^2}{\text{C}^2} \tag{2.2}$$

Question 220.2.1

which allows us to use more meaningful units (to us humans) in the force equation.

Comb and paper bits demo

How about strength? Is gravity or is this force due to charge stronger?

Force	Varies with Distance	Attracts	Repels	Acts without contact	Strength
Gravity	Yes	Always	Never	Yes	Weaker
Charge Force	Yes	Sometimes	Sometimes	Yes	Stronger

Lets try an example problem:

**Example 2.1** Calculate the magnitude of the electric force between the proton and electron in a hydrogen atom. Compare to their gravitational attraction. We expect the electrical force to be larger. We need some facts about Hydrogen

Item	Value
Proton Mass	$1.67 \times 10^{-27}$ kg
Electron Mass	$9.11 \times 10^{-31}$ kg
Proton Charge	$1.6 \times 10^{-19}$ C
Electron Charge	$-1.6 \times 10^{-19}$ C
Proton-electron average separation	$5.3 \times 10^{-11}$ m

then,

$$\begin{aligned}
 F_e &= k_e \frac{|q_1| |q_2|}{r^2} \\
 &= 8.9875 \times 10^9 \frac{\text{N m}^2}{\text{C}^2} \frac{(-1.6 \times 10^{-19} \text{ C})(1.6 \times 10^{-19} \text{ C})}{(5.3 \times 10^{-11} \text{ m})^2} \\
 &= -8.1908 \times 10^{-8} \frac{\text{m}}{\text{s}^2} \text{ kg}
 \end{aligned}$$

and

$$\begin{aligned}
 F_g &= G \frac{m_1 m_2}{r^2} \\
 &= 6.67 \times 10^{-11} \text{ N} \frac{\text{m}^2}{\text{kg}^2} \frac{(1.67 \times 10^{-27} \text{ kg})(9.11 \times 10^{-31} \text{ kg})}{(5.3 \times 10^{-11} \text{ m})^2} \\
 &= 3.6125 \times 10^{-47} \frac{\text{m}}{\text{s}^2} \text{ kg}
 \end{aligned}$$

which shows us what we expected, the gravitational force is very small compared to the electric force.

## Permittivity of free space

It is customary to define an additional constant

$$\epsilon_o = \frac{1}{4\pi k_e} = 8.85 \times 10^{-12} \frac{\text{C}^2}{\text{N m}^2} \quad (2.3)$$

Using this constant

$$F = \frac{1}{4\pi\epsilon_o} \frac{|q_1| |q_2|}{r^2} \quad (2.4)$$

Question 223.21.3

Question 223.21.4

Question 223.21.5

which really does not seem to be an improvement. But if you go on to take an advanced class in electrodynamics you will find that this form is more convenient in other unit systems. So we will adopt it even though it is an inconvenience now.

## Direction of the force

Question 220.2.2

What about direction? So far we have only calculated the magnitude of the force. But a force is a vector, so it must have a direction. Notice that our equation has absolute value signs in it. We will only get positive values from Coulomb's law.

To find a strategy for getting the direction, let's observe two charged objects

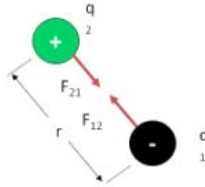

Experiments show that they seem to be pulled straight toward each other. The force seems to be along the line that passes through the center of charge for each of the two charged objects. We have to find this line from the geometry of our situation and our choice of coordinate systems. To make matters worse, we could have two of the same kind of charge.

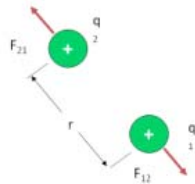

The force will still be on the line connecting the centers of charge, but it will be in the opposite direction compared to the last case where the charges were of different sign. This seems complicated, and it is. We must observe the geometry of our situation and note whether the charges are the same or different signs to find the direction. Our equations can't tell us the direction on their own. You can't put the signs of the charges into the formula and expect a direction to come out! You have to draw the picture. Here is the process:

1. Define your coordinate system.
2. Find the line that connects the centers of charge. The force direction will be on that line.
3. Determine the direction by observing the signs of the charges. If the charges have the same sign, the force will be repulsive, if the charges have different signs, it will be attractive.

## More than two charges

It is great that we know the force between two charges, but we have learned that there are billions of charges in everything we see or touch. It would be nice to be able to use our simple law of force on more than one or two charges. We did this with gravity.

Question 223.21.6

Let's review.

Suppose I have a satellite orbiting the Earth. That satellite feels a force given by

$$\begin{aligned} F_g &= G \frac{M_E m_s}{r^2} \\ &= G \left( \frac{M_E}{r^2} \right) m_s \end{aligned}$$

but consider that on the Earth below the satellite, there is a rock on the surface of the Earth.

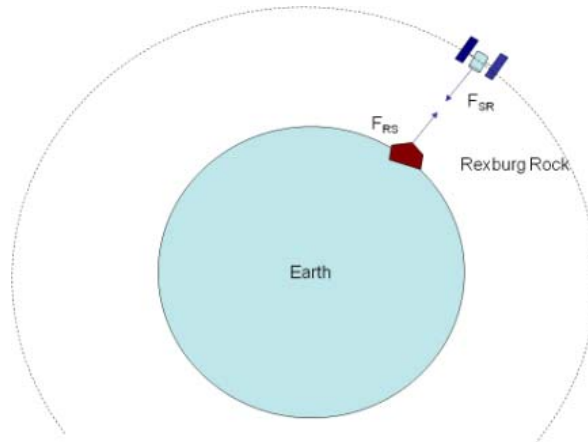

Part of the force due to gravity on the satellite must be due to this rock. We could write our force due to gravity as

$$F_g = G \left( \frac{M_{rest}}{r_{rest}^2} \hat{r}_{rest} + \frac{M_{rock}}{r_s^2} \hat{r}_{rock} \right) m_s$$

where  $M_{rest}$  is the mass of all the rest of the Earth, minus the rock. If we take the Earth rock by rock, we would have

$$F_g = G \left( \sum_i \frac{M_i}{r_i^2} \hat{r}_i \right) m_s$$

where  $M_i$  is the mass of the  $i^{th}$  piece of the Earth and  $\hat{r}_i$  is the direction from  $M_i$  to  $m_s$ . We would not really want to do this calculation, because it would take a long time. Instead, back in PH121 or Dynamics we found we could add up all the mass and treat the Earth as one big ball of mass and represent it as if the mass was all at its center of mass (as long as there is no rotation so no torque). But let's think about all this mass. Does the force between a rock in China and our satellite get diminished because our

rock in Rexburg is in the way?

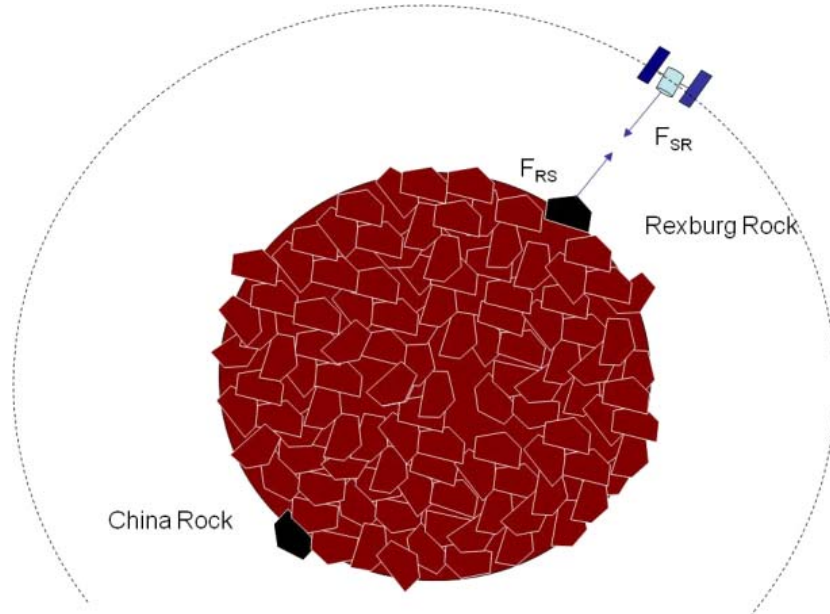

No, the force due to gravity is really the sum of all the little forces between all the parts of the Earth and our satellite. One bit of mass does not interfere with the force from another bit of mass.

Now let's look at the electric force. Suppose we have many charges in some configuration (maybe a round ball of charge). We could call the total charge,  $Q$ . Then our force magnitude on a mover charge  $q_o$ , would be

$$F_e = k_e \frac{|Q| |q_o|}{r^2}$$

The collection of charge  $Q$  would be the environmental charge. But we can picture this as the individual parts of  $Q$  all with little forces pairs acting on  $q_o$  summing up to get  $F_e$ .

$$F_e = k_e \sum_i \left( \frac{|Q_i|}{r_i^2} \hat{\mathbf{r}}_i \right) |q_o|$$

where  $Q_i$  is a piece of the total charge  $Q$ .

This is an amazingly simple idea. The force on a mover charge,  $q_o$ , due to any number of charges is just the sum of the forces due to each charge acting on  $q_o$ . Sometimes the mover charge is called a *test charge*, but we will call it a mover charge and we will call the  $Q_i$  environmental charges.

Suppose in our ball of charge, we have an element of charge on the opposite side of the ball and another element of charge close to us. Would the near charge element “screen

off' or some how reduce the force due to the far charge element?

Like with gravity, it would not. Note that because one charge is farther away, the force from the far charge is not the same magnitude as that of the near charge. But we calculate both using our formula, and add them up (a vector sum) with all the others.

While we are talking about it, it might seem that the rest of the matter in the ball will screen off the electric force. But matter, itself, does not interfere with our electric force. Only other charges will change the force, and then only following the idea of that their forces add as vectors (remember that for electricity they can cancel, because we have both positive and negative charges).

If you took PH123 you will recall that in our study of waves, when we had two waves in a medium we found we could just added up displacements point for point. We called this *superposition*. We will use the same word here, but it has a slightly different meaning. We are not adding up wave displacements. We are adding up forces. But we still do it point for point.

Now where there are forces, there will be Newton's second law! Let's consider a problem. Suppose we have three charges, equally spaced apart as shown where each has the charge of one electron ( $q_e$ ) but the middle charge is positive and the other two are negative

Draw picture on board

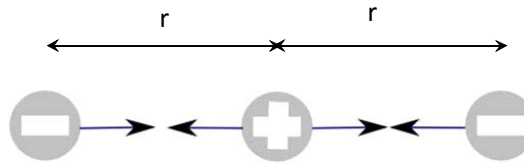

We identify the middle charge as the mover (since we are asked for the force on this charge) and the left and right charges as the environmental charges. We can draw a free body diagram for the mover charge.



and find the net force on the mover charge, then

$$\vec{F}_{net} = m \vec{a} = \vec{F}_R + \vec{F}_L$$



We only have  $x$ -components so we can write this as

$$F_{net_x} = ma = F_{Rx} - F_{Lx}$$

where the minus sign is used for  $F_{Lx}$  because it is pointing to the left and that is usually the minus  $x$  direction.

We may ask, is this mover charge accelerating? We may suspect that the answer is no, but here we have something new. We don't know the magnitude of  $F_R$  or  $F_L$ . We now have to find the magnitudes to know. Back in PH121 you would have been given the magnitude of the forces, but in a charge problem we know how to calculate the magnitudes, so let's do that. We can use the formula for the Coulomb force

$$F = k_e \frac{|q_1||q_2|}{r^2}$$

we can use  $r$  as the distance from the middle charge to each of the other charges since in this special case they are both the same distance from the middle charge. Then

$$F_R = k_e \frac{q_e^2}{r^2}$$

$$F_L = k_e \frac{q_e^2}{r^2}$$

these are the magnitudes. We should notice that  $F_L$  points to the left. So we need to include a minus sign in front of it's magnitude.

$$F_{net_x} = ma = F_{Rx} - F_{Lx}$$

$$F_{net_x} = ma = k_e \frac{q_e^2}{r^2} - k_e \frac{q_e^2}{r^2}$$

$$= 0$$

now we can say that the middle charge is definitely not accelerating.

Of course this is a pretty easy Newton's 2nd law problem. It was all in the  $x$ -direction. But suppose that is not true. Then we need to take components of the forces vectors. Let's try one of those.

Draw picture on board

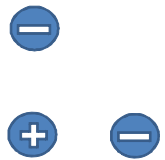

Here is a new configuration of our charges. There will be a Coulomb force between each negative charge the positive charge. What is the net force on the positive charge?

Again we need Newton's second law and the Coulomb force equation. We identify the positive charge as our mover, and the negative charges as the environmental charges.

Our basic equations are

$$F = k_e \frac{|q_1| |q_2|}{r^2}$$

$$\vec{\mathbf{F}} = m \vec{\mathbf{a}}$$

Draw picture on board

but this time we need an  $x$  and a  $y$  Newton's second law equation. Let's draw the free body diagram. I have chosen the positive  $y$ -direction to be upward and the positive  $x$ -direction to be to the right.

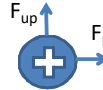

The negative charge that is above our positive charge will cause an upward force. The negative charge to the right will cause a force that pulls to the right. This is a two-dimensional problem, so we need to split our Newton's second law into two one-dimensional problems.

$$F_{net_x} = ma_x = F_L$$

$$F_{net_y} = ma_y = F_{up}$$

so

$$F_{net_x} = k_e \frac{q_e^2}{r^2}$$

$$F_{net_y} = k_e \frac{q_e^2}{r^2}$$

We can see that there will be a force in both the  $x$  and the  $y$  direction. How do we combine these to get the net force? We use our basic equations for combining vectors:

$$F_{net} = \sqrt{F_{net_x}^2 + F_{net_y}^2}$$

$$= \sqrt{\left(k_e \frac{q_e^2}{r^2}\right)^2 + \left(k_e \frac{q_e^2}{r^2}\right)^2}$$

$$= \sqrt{2} \frac{1}{r^2} k_e q_e^2$$

but we are not done. We need a direction. Generally we use the angle with respect to the positive  $x$ -axis.

$$\theta = \tan^{-1} \left( \frac{F_{net_y}}{F_{net_x}} \right)$$

$$= \tan^{-1} \left( \frac{k_e \frac{q_e^2}{r^2}}{k_e \frac{q_e^2}{r^2}} \right)$$

$$= \frac{\pi}{4} \text{ rad}$$

so we have a net force of  $F = \sqrt{2} \frac{1}{r^2} k_e q_e^2$  at a  $45^\circ$  angle with respect to the  $x$ -axis.

Of course, this is still fairly simple, we should also review taking components of vectors that are not directed along the  $x$  and the  $y$  axis. Suppose we move the top charge as shown below

Draw picture on board

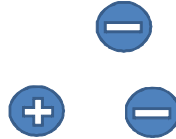

Once again the positive charge is the mover and the negative charges are the environment. Now our free body diagram looks like this:

Draw picture on board

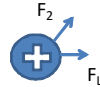

Once again we have a two-dimensional problem. We need to convert it into two one-dimensional problems.

$$F_{net_x} = ma_x = F_{L_x} + F_{2x}$$

$$F_{net_y} = ma_y = F_{L_y} + F_{2y}$$

but we don't know  $F_{L_x}$ ,  $F_{2x}$ ,  $F_{L_y}$ , and  $F_{2y}$ . But our basic equations should include how to make vector components

$$v_x = v \cos \theta$$

$$v_y = v \sin \theta$$

where  $\theta$  is measured from the positive  $x$ -axis. So

$$F_{net_x} = ma_x = F_L \cos \theta_L + F_2 \cos \theta_2$$

$$F_{net_y} = ma_y = F_L \sin \theta_L + F_2 \sin \theta_2$$

and we realize that

$$\theta_L = 0$$

and that

$$\cos(0) = 1$$

$$\sin(0) = 0$$

so

$$ma_x = F_L + F_2 \cos \theta_2$$

$$ma_y = 0 + F_2 \sin \theta_2$$

This gives the  $x$  and  $y$  components of the net force on the positive charge. Using our

Coulomb force for the magnitudes, we have

$$F_{net_x} = k_e \frac{q_e^2}{r^2} + k_e \frac{q_e^2}{r^2} \cos \theta_2$$

$$F_{net_y} = k_e \frac{q_e^2}{r^2} \sin \theta_2$$

I will tell you  $\theta_2 = \frac{\pi}{4}$  rad (or  $45^\circ$ ). So we can find

$$F_{net_x} = k_e \frac{q_e^2}{r^2} + k_e \frac{q_e^2}{r^2} \left( \frac{\sqrt{2}}{2} \right) = k_e \frac{q_e^2}{r^2} \left( 1 + \frac{\sqrt{2}}{2} \right)$$

$$F_{net_y} = k_e \frac{q_e^2}{r^2} \left( \frac{\sqrt{2}}{2} \right)$$

and

$$\begin{aligned} F_{net} &= \sqrt{F_{net_x}^2 + F_{net_y}^2} \\ &= \sqrt{\left( k_e \frac{q_e^2}{r^2} \left( 1 + \frac{\sqrt{2}}{2} \right) \right)^2 + \left( k_e \frac{q_e^2}{r^2} \left( \frac{\sqrt{2}}{2} \right) \right)^2} \\ &= \frac{k_e q_e^2}{r^2} \sqrt{2 + \sqrt{2}} \end{aligned}$$

This is not so nice and easy. The angle for the net force is

$$\begin{aligned} \theta &= \tan^{-1} \left( \frac{k_e \frac{q_e^2}{r^2} \left( \frac{\sqrt{2}}{2} \right)}{k_e \frac{q_e^2}{r^2} \left( 1 + \frac{\sqrt{2}}{2} \right)} \right) \\ &= \tan^{-1} \left( \frac{1}{2} \frac{\sqrt{2}}{\frac{1}{2}\sqrt{2} + 1} \right) \\ &= 0.39270 \text{ rad} \\ &= 22.5^\circ \end{aligned}$$

Note that I am using symbols as long as I can. This will become important in this course. The problems will become very complicated. It is easier to make mistakes if you input numbers early.

Also notice that I carefully placed the charges the same distance,  $r$ , from each other. Of course that will not always be true. If the distances are different, we will use subscripts (e.g.  $r_1, r_2$ ) to distinguish the distances.

## Fields

Let's pause for a minute and think of our mover and environmental objects. We think of the Earth as creating an environment in which the object moves, feeling the

gravitational force. And this is a property of all non-contact forces.

Recall our falling ball. We considered this as an environment of constant acceleration. In this environment, the ball feels a force proportional to their mass

$$\vec{F} = m \vec{g}$$

where  $g = 9.81 \frac{m}{s}$  is the acceleration due to gravity. This is true anywhere near the Earth's surface. We could draw this situation as follows:

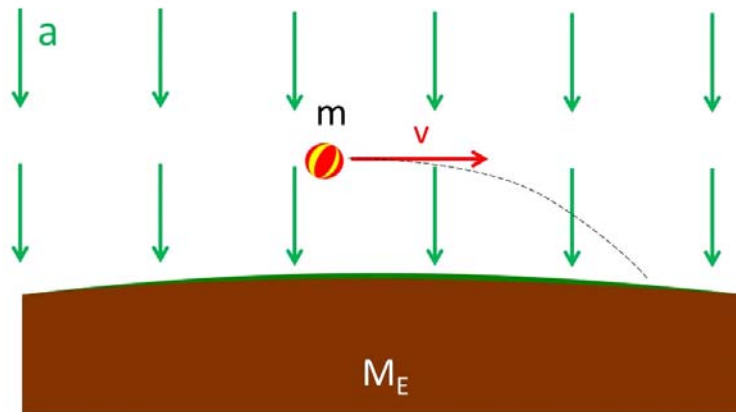

where the environment for constant acceleration is drawn as a series of arrows in the acceleration direction (downward toward the center of the Earth). Anywhere the ball goes the environment is the same. So we draw arrows all around the ball to show that the whole environment around the ball is the same.

Notice that the environment is described by an acceleration,  $g$  given by

$$\vec{g} = \frac{\vec{F}}{m}$$

that is, the environment is described by the force per unit mass.

We know that this environment is caused by the Earth being there. If the Earth suddenly disappeared, then the acceleration would just as suddenly go to zero. So we say that the Earth creates this constant acceleration environment.

Recall that there are two objects involved, the ball and the Earth. Also notice that one object creates an environment that the other object moves in. In our case, the Earth created the environment and the ball moved through the environment. We called the Earth the “Environmental object”, and the ball the “mover.”

We know now that something like this happen with our electrical force. The electric

forces is also a non-contact force. So it makes sense to view one charge as creating an environment in which the other charge moves. But if there is an environment, what would that environment be. Would it be an acceleration, or something else?

Michael Faraday came up with answers to this questions. To gain insight into his answers, let's consider our force again.

$$F_e = k_e \frac{|Q_E| |q_m|}{r^2}$$

but let's take  $q_m$  as a very small test charge that we can place near a larger distribution of charge  $Q_E$ . This is like the Earth and our small ball. The large  $Q_E$  is the environmental charge and the small  $q_m$  is the mover charge.

$$F_e = k_e \frac{|Q_E| |q_m|}{r^2}$$

We want  $q_m$  to be so small that it can't make any of the parts of  $Q_E$  rearrange themselves or any of the atoms forming the body that is charged with  $Q_E$  to polarize. Then we define a new quantity

$$\vec{E} = \frac{\vec{F}}{q_m}$$

This is the force per unit charge. This is very like our gravitational acceleration which is a force per unit mass. Then

$$\vec{F} = q_m \vec{E} \quad (2.5)$$

This is really like

$$\vec{F} = m \vec{g}$$

but with the mass replaced by  $q_m$  and the acceleration replaced by this new force-per-unit-charge thing. For gravity it is the mass that made the gravitational pull. With the electric force it is the charge that creates the pull. So replacing  $m$  with  $q_m$  makes some sense. But what does it mean that the acceleration has been replaced by  $\vec{E}$ . Well, since  $\vec{g}$  was the representation of the environment, can see that this new quantity is taking the place of the environment, but it can't be an acceleration. It does not have the right units. Let's investigate what it is.

Let's write the magnitude of  $E$

$$\begin{aligned} E &= \frac{F}{q_m} \\ &= \frac{k_e \frac{|Q_E| |q_m|}{r^2}}{q_m} \\ &= k_e \frac{Q_E}{r^2} \end{aligned}$$

van de Graff and test charge

But this is really not a quantity that we have seen before It depends on how far away we are from the environmental charge  $Q_E$ . It has a value at every point in space—the

whole universe! (think of our acceleration environment being all around the moving ball) though it's values for large  $r$  are very small. The quantity is only large in the near vicinity of the charge,  $Q_E$ .

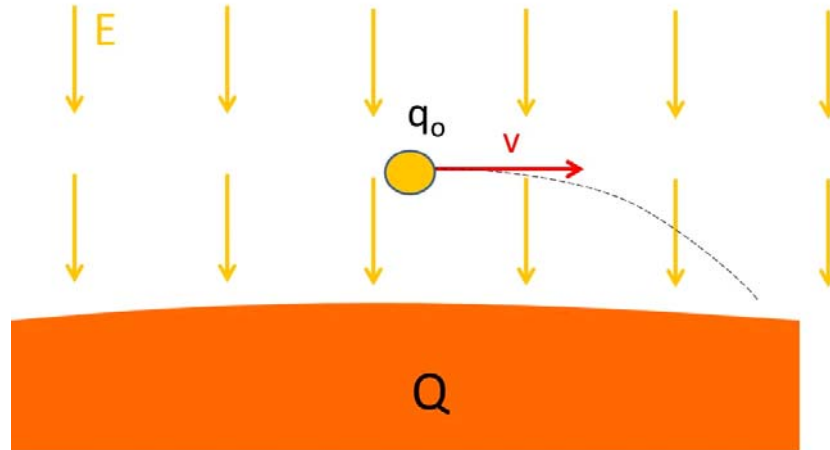

We can picture this quantity as being like a foot ball field with something (an environmental charge) hidden out there on the grass. If we know where the object is, we can tell a searcher how “warm” or “cold” they are as they wander around looking for the object. For every location, there is a value of “warmness.” If we extend this idea to three dimensions, we are close to a picture of  $\vec{E}$ . The environment quantity  $\vec{E}$  has a value at every point in three dimensional space. Since this is a new quantity, we need to give it a name. We will call it an *electric field*. But we have to add one more complication. It is a vector, so it also has a direction at each point in space as well. This direction is the direction the force would be on  $q_o$ , the mover, if we placed it at that location.

A field is a quantity that has a value (magnitude and/or direction) at every point in space.

But where does this field come from? We say that an environmental charge  $Q_E$  creates a field

$$\vec{E} = k_e \frac{Q_E}{r^2} \hat{r} \quad (2.6)$$

centered at the charge location. The field is our environment for our mover.

Now we can understand more about how gravity works! Have you wondered how a satellite knows that the Earth is there and that it should be pulled toward the Earth? The Earth sets up a *gravitational field* because it has mass. The gravitational field shows up as an acceleration field. The satellite (the mover) feels the gravitational field because the field exists at the location of the satellite (it exists at all locations, so it exists at the

Question 223.21.7 satellite's location). The satellite does not have to know that the Earth is there, because it feels the field right where it is. The satellite reacts to the field, not the Earth that created the field.<sup>6</sup>

Likewise, our charge  $Q_E$  has the property of creating an *electric field* as the environment around it. Other charges (movers) will feel the field at their locations, and therefore will feel a force due to the field created by  $Q_E$ .

## Field Lines

We need a way to draw the environment created by the environmental charge  $Q_E$ . We could draw lots of arrows like in the previous pictures. and we will do this sometimes. But there is another way to draw the environment that has become traditional. Have you ever taken iron filings and placed a magnet near them? If you do, you will notice that the filings seem to line up.

Question 223.21.10

Magnet and Iron Filings

If you took PH121 you probably heard that there is a magnetic force. It is a non-contact force, so we expect it has a *magnetic field*. The iron filings are aligning because they are acted upon by the field. It is natural to represent this field as a series of lines like the ones formed by the iron filings. We will do this in a few lectures!

But there is a similar experiment we can do with the electric force. This is harder, but we can use small seeds or pieces of thread suspended in oil. These small things become polarized in an electric field. They line up like the iron filings.

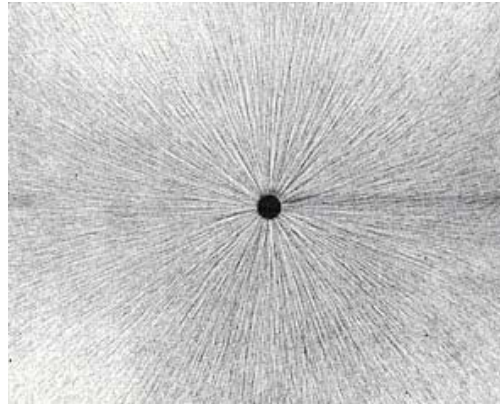

[http://stargazers.gsfc.nasa.gov/images/geospace\\_images/electricity/elec\\_field\\_lines.jpg](http://stargazers.gsfc.nasa.gov/images/geospace_images/electricity/elec_field_lines.jpg)

We can represent the electric field by tracing out these lines. The last figure would look

---

<sup>6</sup> Here I am taking a quantum mechanical view of gravity. In General Relativity, the "field" is space that is warped by the mass of the Earth.



like this

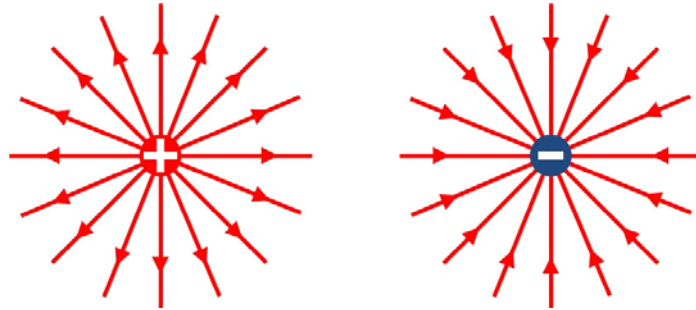

We can't tell if the charge was negative or positive from oil suspension picture, but if it was positive, by convention we draw the field lines as coming out of the charge. If it were negative the field lines would be drawn as going in to the charge. Here is a combination of a negative and a positive charge or dipole.

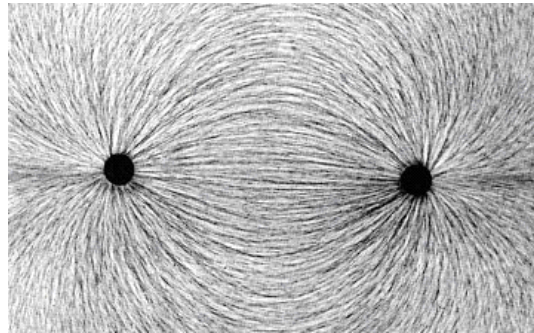

[http://stargazers.gsfc.nasa.gov/images/geospace\\_images/electricity/elec\\_field\\_lines2.jpg](http://stargazers.gsfc.nasa.gov/images/geospace_images/electricity/elec_field_lines2.jpg)

In this case both the positive and negative charges are working together to make the environment or field that a third charge could move through. The field line drawing would look like this.

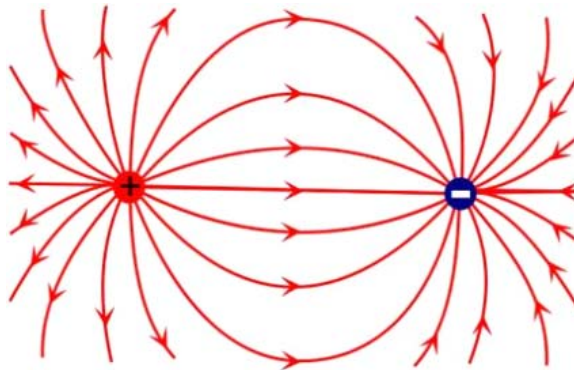

This combination of positive and negative charges had equal charges, the only difference was the sign change. Here is one where the positive charge has more charge

than the negative charge.

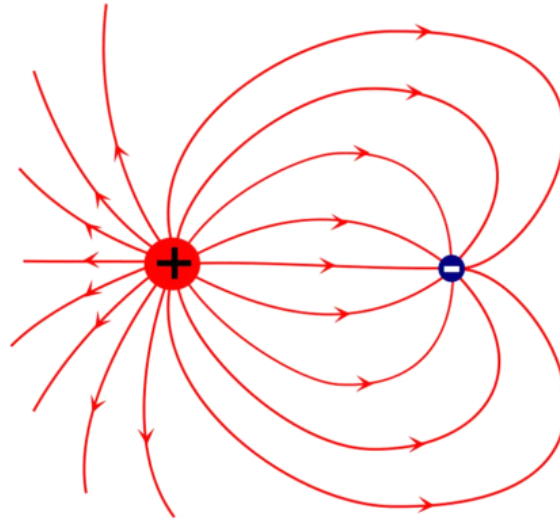

Notice that the number of field lines is proportional to the field, but there is no set proportionality. If the field from one charge is twice that of the other, we pick a number of field lines for, say, the negative charge, and double the lines on the larger positive charge.

This gives us a way to picture the electric field in our minds!

Some things to notice:

1. The lines begin on positive charges
2. The lines end on negative charges
3. If you don't have matching charges, the lines end infinitely far away (like the single charges in the first picture).
4. Larger charges have more lines coming from them
5. Field lines cannot cross each other
6. The lines are only imaginary, they are a way to form a mental picture of the field.

Question 223.21.11

We only draw the field lines for the environmental charges. Of course the mover charge also makes a field, but this self-field can't cause the mover charge to move. If it could we could have perpetual motion and that violates the second law of thermodynamics. Since the mover's self-field is not participating in making the motion, we won't take the time to draw it!<sup>7</sup>

<sup>7</sup> This picture will be a little more complicated when we allow for relativistic motion of charges and

Remember, field lines are not real, but are a nice way to draw the field made by the environmental charge. We will use field lines often in drawing pictures as part of our problem solving process.

## On-Line fun

An applet that demonstrates the electric field of point charges can be found here:

[http://phet.colorado.edu/sims/charges-and-fields/charges-and-fields\\_en.html](http://phet.colorado.edu/sims/charges-and-fields/charges-and-fields_en.html)

If you prefer a video game, try Electric Field Hockey:

<http://phet.colorado.edu/en/simulation/electric-hockey>

As a wacky example of Coulomb forces, see this video of charged water droplets orbiting charged knitting needles on the Space Shuttle:

[http://www.nasa.gov/multimedia/videogallery/index.html?media\\_id=131554451](http://www.nasa.gov/multimedia/videogallery/index.html?media_id=131554451)

## Basic Equations

---

other more difficult effects, but that can wait for more advanced physics courses. For most engineering applications, this is a great approximation.



# 3 Electric Fields of Standard Charge Configurations Part I

## Fundamental Concepts

- Adding of vector fields for point charges
- Standard configurations of charge

## Standard Charge Configurations

Actual engineering projects or experimental designs require detailed calculations of fields using computers. These field simulations use powerful numerical techniques that are beyond this sophomore class. But we can gain some great insight by using some basic models of simple charged objects. We will often look at the following models:

Standard Configurations of Charge
Point charge
Several point charges
Line of Charge
Semi-infinite sheet of charge
Charged sphere
Charged spherical shell
Ring of Charge

## Point Charges

We have already met one of these standard configurations, the point charge

$$\vec{E} = \frac{1}{4\pi\epsilon_0} \frac{qE}{r^2} \hat{r}$$

The field of the point charge is represented below

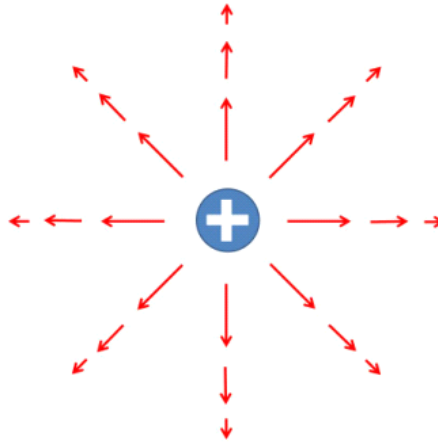

This picture requires a little explanation. The arrows are larger nearer the charge to show that the field is stronger. But note that each arrow is the magnitude and direction of the charge at one point. We really need a three dimensional picture to describe this, and even then the fact that the arrows have length can be misleading. The long arrows cover up other points, that should also have arrows. We can only draw the field at a few points, and at those points the field has both magnitude and direction. But we must remember that there is really a field magnitude and direction at every point.

The extension is a group of point charges

$$\vec{\mathbf{E}} = \sum_i \vec{\mathbf{E}}_i$$

where we recognize that we are summing vectors. Let's take a look at a few combinations of charges and find their fields

## Two charges

Let's go back to our idea of an environmental charge,  $Q_E$ , and a mover charge,  $q_m$ . The mover charge is considered to be small enough that its effect on  $Q_E$  is negligible. So the field due to the large charge is unaffected by this small charge.

Of course, the total field is a superposition of both fields. But recall that the mover's self-field can't move the mover. So we don't draw the field due to  $q_m$ . We can envision an environmental field that is just due to the environmental charge,  $Q_E$ , as if there are no other charges anywhere in the whole universe. Of course this is not the case, but this is how we think of the field *due to* charge  $Q_E$ .

Question 223.22.1

Question 223.22.2

We can identify that a charge  $q_m$  placed in this field due to  $Q_E$  will feel a force

$$\begin{aligned}\vec{\mathbf{F}}_e &= q_m \vec{\mathbf{E}} \\ &= \frac{1}{4\pi\epsilon_o} \frac{Q_E q_m}{r^2} \hat{\mathbf{r}}\end{aligned}$$

due to the field

$$\vec{\mathbf{E}} = \frac{1}{4\pi\epsilon_o} \frac{Q_E}{r^2} \hat{\mathbf{r}}$$

where this field is just due to  $Q_E$  and does not contain the contribution from  $q_m$ . So the charge  $q_m$  only feels a force due to the field created by charge  $Q_E$ . A third charge,  $q_{new}$  brought close to the other two would feel both  $\vec{\mathbf{E}}_Q$  and  $\vec{\mathbf{E}}_q$ . Then both  $Q_E$  and our original  $q_m$  would be environmental charges and the new charge  $q_{new}$  would be the mover. At this point, we would probably relabel  $Q_E$  and  $q_m$  as  $Q_1$  and  $Q_2$  and relabel  $q_{new}$  as  $q_m$  so we could tell that the original two charges are now the environment and the new charge is the mover.

### Vector nature of the field

Question 223.22.3

Question 223.22.4

Remember that the field is a force per unit charge. Forces add as vectors, so we should expect fields to add as vectors too. Let's do a problem.

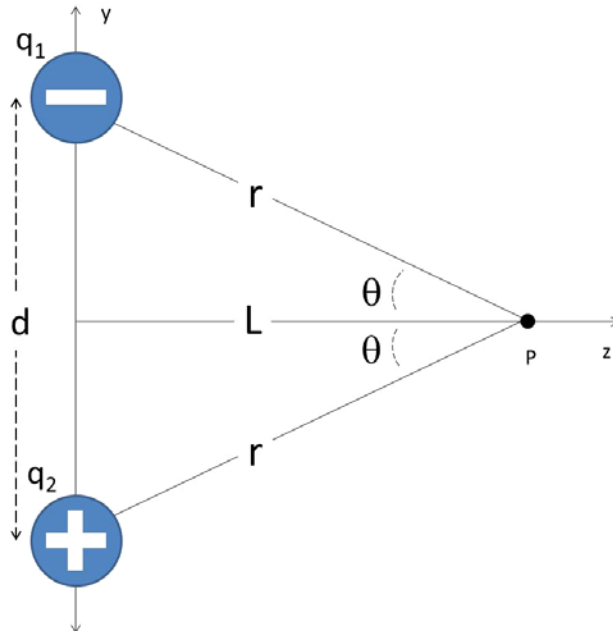

Two charges are separated by a distance  $d$ . What is the field a distance  $L$  from the

center of the two charges?

We should recognize this as our old friend, the dipole.

Note that both of these charges are environmental charges. We are asked in this problem to find the environment, the field. We don't really have a mover charge. But we could pretend we do have a mover,  $q_o$  at point  $P$  where we want to know the environment if it helps us picture the situation. But really we are calculating what the environment around the two charges will be.

We start by drawing the situation. I chose not to draw field lines. Instead I drew the field vectors at the point,  $P$ , where we want the field. The field lines would tell me about the whole environment everywhere, and that might be useful. But this problem only wants to know the field at one point,  $P$ . So it was less work to draw the field using vectors at our one point.

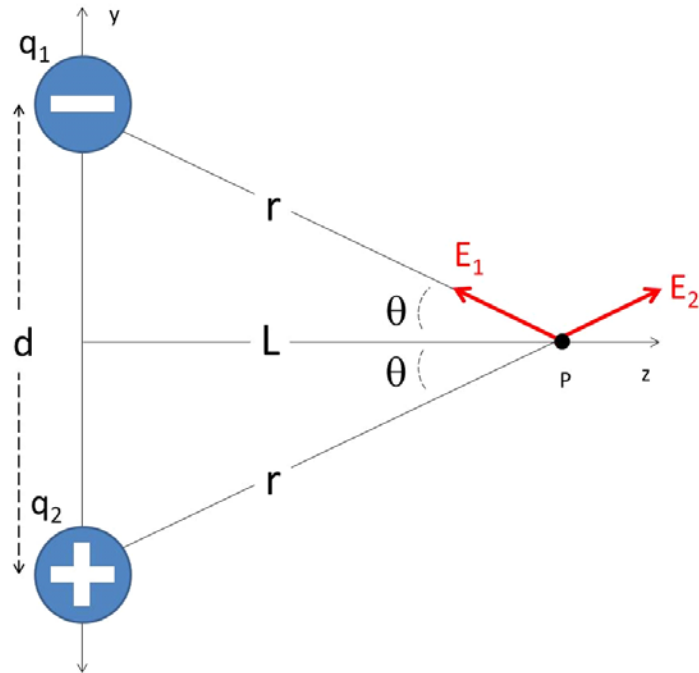

Note that I need a vector for each of the environmental charges. Each contributes to the environment. The contribution to the field due to environmental charge  $q_1$  is labeled  $E_1$  and likewise the contribution to the field from environmental charge  $q_2$  is labeled  $E_2$ .



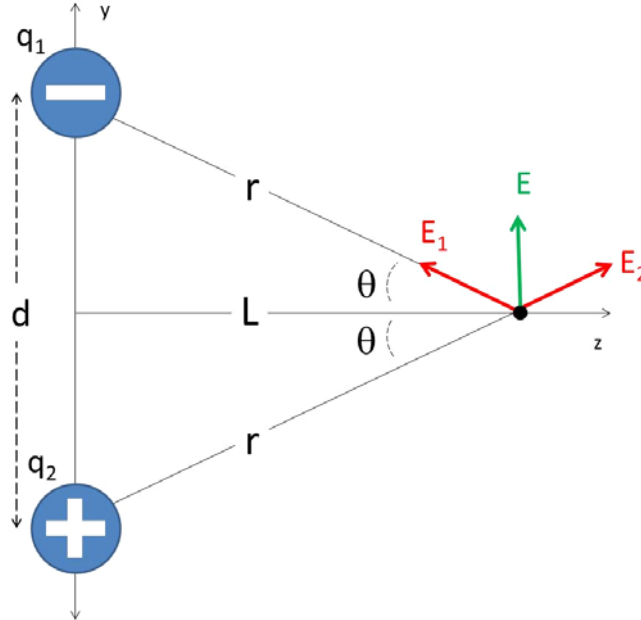

The net environment is the superposition of the fields due to each of the environmental charges.

$$\vec{\mathbf{E}}_{net} = \vec{\mathbf{E}}_1 + \vec{\mathbf{E}}_2$$

From the figure, we see that if we had a small mover charge,  $q_o$  on the axis a distance at point  $p$  then we would get two forces, one from each of the environmental charges  $q_1$  and  $q_2$ . We can use Newton's second law to find the net force on our imaginary  $q_o$ . Of course, since this is a two-dimensional problem we will split it into two one-dimensional problems.

$$F_{net_z} = ma_z = -F_1 \cos \theta + F_2 \cos \theta$$

$$F_{net_y} = ma_y = F_1 \sin \theta + F_2 \sin \theta$$

we can see that the distance from each charge to point  $P$  is

$$r = \sqrt{\frac{d^2}{4} + L^2}$$

so

$$\sin \theta = \frac{d}{2\sqrt{\frac{d^2}{4} + L^2}}$$

we also know from Coulomb's law that

$$F_1 = F_2 = \frac{1}{4\pi\epsilon_o} \frac{qq_o}{r^2}$$

but we want the field, so we need to divide all of this by  $q_o$

$$E_1 = E_2 = \frac{1}{4\pi\epsilon_o} \frac{q}{r^2}$$

Our Newton's second law becomes an equation for the components of the combined electric field.

$$\begin{aligned}\frac{F_{net_z}}{q_o} &= -\frac{F_1}{q_o} \cos \theta + \frac{F_2}{q_o} \cos \theta \\ \frac{F_{net_y}}{q_o} &= \frac{F_1}{q_o} \sin \theta + \frac{F_2}{q_o} \sin \theta\end{aligned}$$

or just

$$\begin{aligned}E_{net_z} &= -E_1 \cos \theta + E_2 \cos \theta \\ E_{net_y} &= E_1 \sin \theta + E_2 \sin \theta\end{aligned}$$

We can see from the figure that in the  $x$ -direction we will have no net field,

$$E_z = -E_1 \cos(\theta) + E_1 \cos \theta = 0$$

But in the  $y$ -direction we have

$$\begin{aligned}E_y &= E_1 \sin \theta + E_2 \sin \theta \\ &= 2E_1 \sin \theta \\ &= \frac{2}{4\pi\epsilon_o} \frac{q}{r^2} \sin \theta\end{aligned}$$

and since we found that

$$\sin \theta = \frac{d}{2\sqrt{\frac{d^2}{4} + L^2}}$$

we can write our field as

$$\begin{aligned}E_y &= \frac{2}{4\pi\epsilon_o} \frac{q}{\frac{d^2}{4} + L^2} \frac{d}{2\sqrt{\frac{d^2}{4} + L^2}} \\ &= \frac{1}{4\pi\epsilon_o} \frac{qd}{\left(\frac{d^2}{4} + L^2\right)^{\frac{3}{2}}}\end{aligned}$$

This is our total field at the distance  $L$  away on the axis. This is the environment that a mover charge could move through.

Note that we pretended that we had a mover,  $q_o$ , but in finding the field the  $q_o$  canceled out, so indeed we are left with just the environment in our calculation, we just have the field.

Now suppose our mover charge is very far away. That is, suppose we make  $L$  very large. So large that  $L \gg d$  then

$$\lim_{L \gg d} \frac{1}{\left(\frac{d^2}{4} + L^2\right)^{\frac{3}{2}}} = \frac{1}{L^3}$$

Then our field becomes

$$E = E_y = \frac{2}{4\pi\epsilon_o} \frac{qd}{\left(\frac{d^2}{4} + L^2\right)^{\frac{3}{2}}}$$

$$= \frac{1}{4\pi\epsilon_o} \frac{qd}{L^3}$$

Since many charged particles are small, like atoms or molecules, this limit is often useful.

Now suppose we repeat the calculation, but this time we chose a point that is  $L$  away, but that is on the  $y$ -axis above the charges, we would find

$$E = E_y = \frac{2}{4\pi\epsilon_o} \frac{qd}{L^3}$$

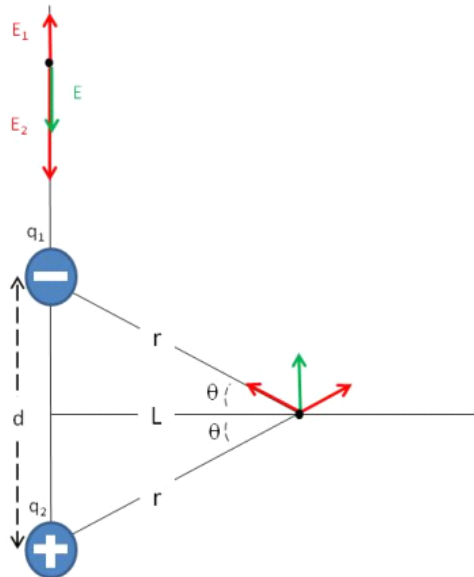

The result is similar, but the field is a little stronger in this direction.

Let's look at one of these cases by graphing it.

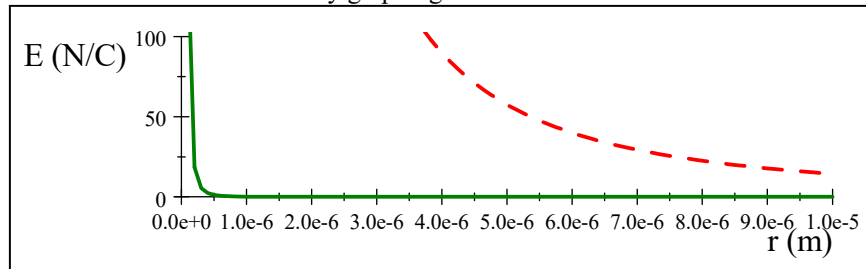

We can see that the dipole field (solid green line) falls off much faster than a point

charge field (dashed red line). This makes sense because the farther away we get, the more it looks like the two charges are right next to each other, and since they are opposite in sign, they are essentially neutral when viewed together from far away. We can see why atoms don't exhibit a significant charge forces at normal distances.

This arrangement of charges we already know as a dipole. We are treating the two charges as a unit making the environment that other charges might move in. Since we are treating the two charges as one unit, it is customary to define a quantity

$$p = qd$$

and to make this a vector by defining the direction of  $p$  to be from the negative to the positive charge along the axis.

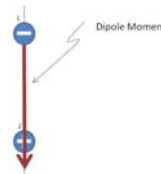

Then we can write the dipole field as

$$\vec{E}_y = \frac{2}{4\pi\epsilon_0} \frac{\vec{p}}{L^3}$$

We could also treat this dipole as a complicated mover charge in some other environmental field!. Then this quantity  $\vec{p}$  will help us understand how a dipole will move when placed in an environmental electric field. For example, we know that water molecules are dipoles. A microwave oven creates a strong environmental electric field that makes the water molecules rotate. When we studied rotational motion we found a mass-like term that helped us to know how difficult something was to make rotate. That was the moment of inertia. This dipole term,  $\vec{p}$ , will tell us how likely a dipole is to spin, so we will call  $\vec{p}$  the *dipole moment*.

### Three charges

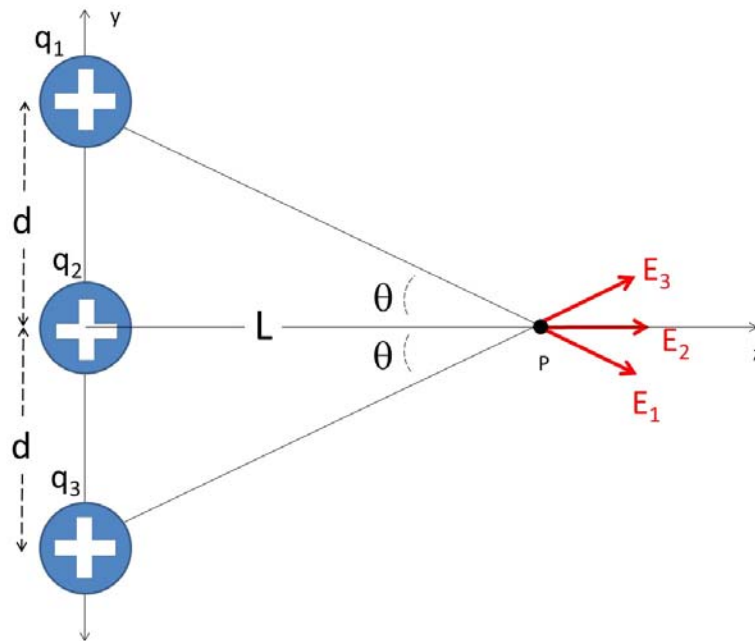

Question 223.22.5

We are working our way toward many charges that will require using integration to sum up the contributions to the field. But let's make this transition slowly. Next let's add just one more environmental charge, for a total of three.

Let's just start with the fields this time. From our picture, we expect in this case to have only  $z$ -components. Since all the charges are the same sign,

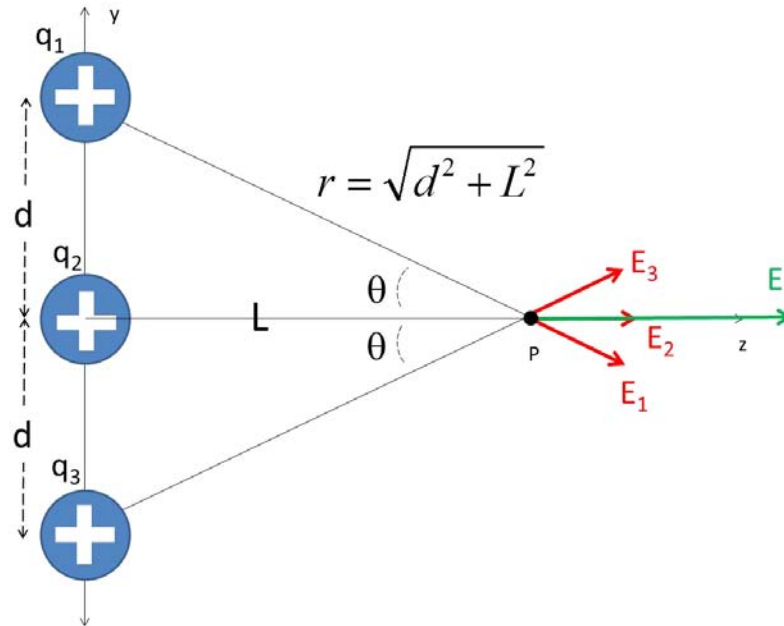

then

$$E_{net_z} = E_1 \cos(-\theta) + E_2 + E_3 \cos(\theta)$$

We can guess from symmetry that

$$E_1 = E_3 = \frac{1}{4\pi\epsilon_0} \frac{q}{r^2}$$

But this time, since we have redefined  $d$ , the distance from  $q_1$  and  $q_3$  to the point  $P$  where we want to know the field is

$$r = \sqrt{d^2 + L^2}$$

so

$$E_1 = E_3 = \frac{1}{4\pi\epsilon_0} \frac{q}{d^2 + L^2}$$

and

$$E_2 = \frac{1}{4\pi\epsilon_0} \frac{q}{L^2}$$

and observing the triangles formed and remembering our trigonometry, we have

$$\cos \theta = \frac{L}{\sqrt{d^2 + L^2}}$$

so

$$\begin{aligned} E_z &= \frac{1}{4\pi\epsilon_0} \frac{q}{d^2 + L^2} \frac{L}{\sqrt{d^2 + L^2}} \\ &+ \frac{1}{4\pi\epsilon_0} \frac{q}{L^2} \\ &+ \frac{1}{4\pi\epsilon_0} \frac{q}{d^2 + L^2} \frac{L}{\sqrt{d^2 + L^2}} \end{aligned}$$

or

$$E_z = \frac{q}{4\pi\epsilon_o} \left( \frac{2L}{(d^2 + L^2)^{\frac{3}{2}}} + \frac{1}{L^2} \right)$$

This is our answer.

Once again let's consider the limit  $L \gg d$ . If our answer is right, when we get very far from the group of charges they should look like a single charge with the amount of charge being the sum of all three environmental charges. In this limit

$$\lim_{L \gg d} \frac{1}{(d^2 + L^2)^{\frac{3}{2}}} = \frac{1}{L^3}$$

so

$$\begin{aligned} E_z &\approx \frac{q}{4\pi\epsilon_o} \left( \frac{2L}{L^3} + \frac{1}{L^2} \right) \\ &= \frac{1}{4\pi\epsilon_o} \left( \frac{3q}{L^2} \right) \end{aligned}$$

so on the central axis

$$\vec{\mathbf{E}} \approx \frac{1}{4\pi\epsilon_o} \left( \frac{3q}{L^2} \right) \hat{\mathbf{k}}$$

And indeed, this is very like one charge that is three times as large as our actual charges if we get far enough away.

This shows us a pattern we will often see. Far away, our field looks like what we would expect if the net charge were all congregated in a point. Near the charges, we must calculate the superposition of the fields. But far away we can treat the distribution as a point charge. This is very like what we did with mass in PH121 or Dynamics. We could often treat masses as point masses at the center of mass, if the distances involved were larger than the mass sizes.

Question 223.22.6

## Combinations of many charges

We have found the field from a point charge.

$$\vec{\mathbf{E}} = \frac{1}{4\pi\epsilon_o} \frac{qE}{r^2} \hat{\mathbf{r}} \quad (3.1)$$

where the field is in the same direction as  $\hat{\mathbf{r}}$  if the charge is positive, and in the opposite direction if the charge is negative (think of our field lines, they go toward the negative charge). This will become one of a group of standard charge configurations that we will use to gain a mental picture of complex configurations of charge. We have done this already for combinations of point charges. We can combine the point charge fields to get the total field.

The other standard models are combinations of many, many charges.

### Line of Charge

Another is an infinitely long line of charge, or a infinite charged wire. Since this long line of charge is infinite, it must have an infinite amount of charge. But we can describe “how much” charge it has with a linear charge density

$$\lambda = \frac{Q}{L}$$



### Semi-infinite sheet of charge

A sheet or plane of charge, usually a semi-infinite sheet of charge is also useful

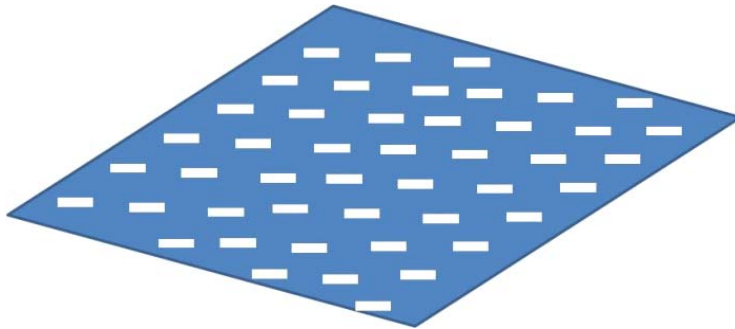

We have the same problem of having infinite charge, but if we define an amount of charge per unit area

$$\eta = \frac{Q}{A}$$

we can compare sheets that are more charge rich than others.

### Sphere of charge

Finally, we have drawn a sphere of charge already



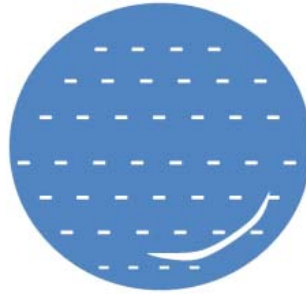

We can define an amount of charge per unit volume to help describe this distribution

$$\rho = \frac{Q}{V}$$

The spherical shell of charge is related to a sheet of charge, so we will include it here

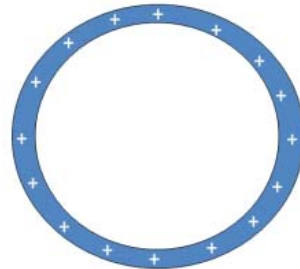

This configuration of charge is drawn in cross section like the others. From your calculus experience you can guess that a spherical shell of charge with a certain volume charge density might be useful in integration, but we also can easily produce such a configuration of charge by charging a round balloon or a spherical conductor.

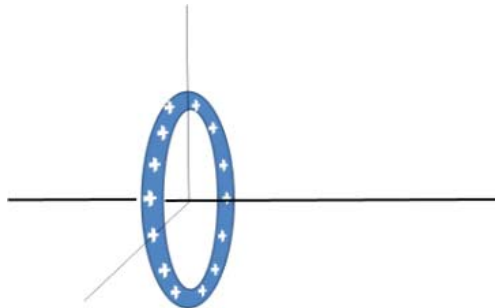

The ring of charge is similar to the spherical shell, but is also much like the line of charge.

In our next lecture, we will take on the job of finding the fields that result from these last few charge configurations except the spherical shell, which will have to wait a few lectures.

### On-Line Fun

A point charge field at a distant point visualization applet can be found at following this link:

<http://ocw.mit.edu/ans7870/8/8.02T/f04/visualizations/electrostatics/03-ChargeField3d/03-chargeField320.html>

For a 2D visualization of the field try:

<http://www.falstad.com/emstatic/index.html>

And here is a 3D visualization:

<http://www.falstad.com/vector3de/>

### Basic Equations

# 4 Electric Fields of Standard Charge Configurations Part II

## Fundamental Concepts

- Integrating vector fields for continuous distributions of charge
  - Start with  $\vec{\mathbf{E}} = \frac{1}{4\pi\epsilon_0} \int \frac{dq}{r^2} \hat{\mathbf{r}}$
  - find an expression for  $dq$
  - Use geometry to find expressions for  $r$  and to eliminate  $\hat{\mathbf{r}}$
  - Solve the integral

## Fields from Continuous Charge Distributions

Question 223.23.1

Suppose we have a continuous distribution of charge with some mover charge  $q_m$  fairly far away. You might ask, how do we get a continuous distribution of charge? After all, charge seems to be quantized. Well, if we have a collection of charges where the distances between the individual charge carriers are much smaller than the distance from the whole collection of charges to some point where we want to measure the field (where the mover charge might be), then in our field calculations at this distant point we can model the charge distribution causing the field as continuous. As an analogy, think of your computer screen. It is really a collection of dots of light. But if we are a few feet away, we see a continuous picture. We can treat the dots as though there were no space in between them. For our continuous charge model, it is the same. We are supposing we are observing from far enough away that we won't notice the effects of the charges being separated by small distances.

We should remember, though, that this is a macroscopic view. At some point it must break down, since charge is carried in discrete amounts. If we want the field very close to a distribution of charges, we must treat our charge distribution as a collection of individual charges like we did in the last lecture. Notice in our last lecture that we found that the field infinitely far from the charges was always zero. That is too far away

for our continuous charge model to be useful. But if we went far enough away—but not too far, the three charge configuration looked like a point charge with a total charge that was the sum of the individual charges. At such distances, the separation between the charges become unimportant. This is the sort of large distance we are talking about in our continuous charge distribution model.

To find the field due to a continuous charge distribution, we break up the charged object into small pieces in a calculus sense. Each small piece is still a continuous distribution of charge. It will have an amount of charge  $\Delta q_E$ , where here the  $\Delta$  means “a small amount of.” Then we calculate the field due to this element of charge. We repeat the process for each element using the superposition principle to sum up all the individual field contributions. This is very like our method of finding the field from individual charges, only instead of a sum we want to let  $\Delta q_E$  becomes very small and use an integral. The field due to this bit of charge is

$$\Delta \vec{\mathbf{E}} = \frac{1}{4\pi\epsilon_o} \frac{\Delta q_E}{r^2} \hat{\mathbf{r}}$$

Recall that here  $\Delta$  means “a small bit of” and is not a difference between two charge values or two field values. We learned that we can sum up the fields from each piece

$$\begin{aligned} \vec{\mathbf{E}} &\approx \sum_i \Delta \vec{\mathbf{E}}_i \\ &\approx \frac{1}{4\pi\epsilon_o} \sum_i \frac{\Delta q_i}{r_i^2} \hat{\mathbf{r}}_i \end{aligned}$$

and now we use our M215 (or M113) tricks to convert this into an integral. We let our small element of charge become very small (but not so small that we violate our assumption that the charge distribution of  $\Delta q_E$  is continuous).

$$\begin{aligned} \vec{\mathbf{E}} &= \lim_{\Delta q_i \rightarrow 0} \frac{1}{4\pi\epsilon_o} \sum_i \frac{\Delta q_i}{r_i^2} \hat{\mathbf{r}}_i \\ &= \frac{1}{4\pi\epsilon_o} \int \frac{dq_E}{r^2} \hat{\mathbf{r}} \end{aligned}$$

The limits of the integration must include the entire distribution of charge if we want the total field. This will be our basic equation for finding the field for continuous distributions of charge.

Let’s do some examples.

## Line of charge

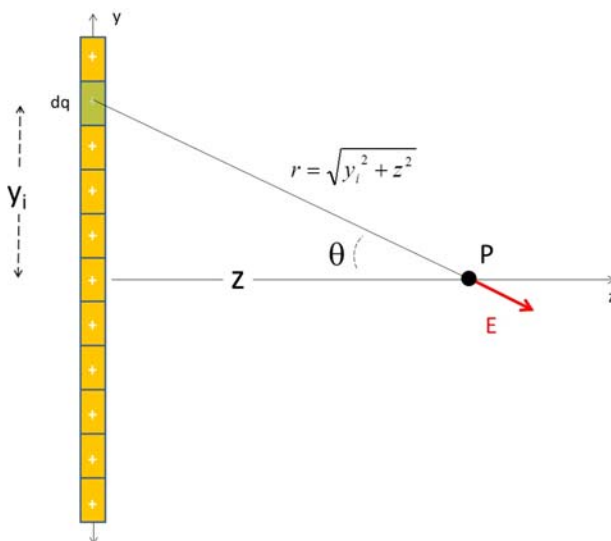

## Question 223.23.2

Let's try this for a line of charge. This may seem like a simple charge configuration, but this problem is really quite challenging. Let's say that the charge is evenly distributed along the line. Then we can use the linear charge density

$$\lambda = Q/L$$

to find  $dq$ . The quantity  $Q$  is the total amount of charge on the wire and  $L$  is the length of the wire. Then

$$dq = \lambda dy$$

Of course, we may not always have a constant density, then we need to have an element of charge that varies with position. For a line charge, we would have

$$dq = \lambda(y) dy$$

but for now, let's assume the linear charge density is constant. Our basic formula tells us that we should add up all the  $dq$  elements. But we have an obstacle. We need a different  $\hat{r}_i$  for every  $dq_i$ . How do we deal with this?

MIT Visualization:  
integrating a line of  
charge

Just like with last lecture, we only need the component of the part of the field that does not cancel. Here we need to have drawn a good picture. From our drawing we can tell that, in this case, only the  $z$  component will survive (the  $y$ -components cancel). So we only need to find

$$E_z = \vec{E} \cdot \hat{k}$$

This is a good thing, because our basic equation has an  $\hat{\mathbf{r}}$  in it

$$\vec{\mathbf{E}} = \frac{1}{4\pi\epsilon_o} \int \frac{dq}{r^2} \hat{\mathbf{r}}$$

and we don't know how to do this integral including the  $\hat{\mathbf{r}}$ . As always we will take this two-dimensional problem and split it into two one-dimensional problems before we can proceed. We will split our problem into  $z$  and  $y$ -components. But since we know that only the  $z$ -component will survive, we can just calculate the  $z$ -component,

$$\begin{aligned} E_z &= \vec{\mathbf{E}} \cdot \hat{\mathbf{k}} \\ &= \frac{1}{4\pi\epsilon_o} \int_{-L/2}^{L/2} \frac{dq}{r^2} \hat{\mathbf{r}} \cdot \hat{\mathbf{k}} \end{aligned}$$

and we recognize

$$\hat{\mathbf{r}} \cdot \hat{\mathbf{k}} = \cos \theta$$

So we are left with just

$$E_z = \frac{1}{4\pi\epsilon_o} \int_{-L/2}^{L/2} \frac{dq}{r^2} \cos \theta$$

which is much more likely to be integrable with what we know from M113 or M215.

Like in our last lecture, we will want to express

$$r = \sqrt{y^2 + z^2}$$

and it makes it easier if we write

$$\cos \theta = \frac{z}{\sqrt{y^2 + z^2}}$$

Then our integral can be written as

$$\begin{aligned} E_z &= \frac{1}{4\pi\epsilon_o} \int_{-L/2}^{L/2} \frac{\lambda dy}{y^2 + z^2} \frac{z}{\sqrt{y^2 + z^2}} \\ &= \frac{\lambda z}{4\pi\epsilon_o} \int_{-L/2}^{L/2} \frac{dy}{(y^2 + z^2)^{\frac{3}{2}}} \end{aligned}$$

This now looks like a M215 or M113 problem. We can find this integral in an integral table or you can use your calculator, or a symbolic math package, or you can remember your M215 or M113 and prove that

$$\int_{-L/2}^{L/2} \frac{dx}{(x^2 \pm a^2)^{\frac{3}{2}}} = \frac{\pm x}{a^2 \sqrt{x^2 \pm a^2}}$$

so

$$\begin{aligned}
 E_z &= \frac{\lambda z}{4\pi\epsilon_o} \int_{-L/2}^{L/2} \frac{dy}{(y^2 + z^2)^{3/2}} \\
 &= \frac{\lambda z}{4\pi\epsilon_o} \left[ \frac{y}{z^2 \sqrt{y^2 + z^2}} \right]_{-L/2}^{L/2} \\
 &= \frac{\lambda z}{4\pi\epsilon_o} \left[ \frac{L/2}{z^2 \sqrt{(L/2)^2 + z^2}} - \frac{-L/2}{z^2 \sqrt{(-L/2)^2 + z^2}} \right] \\
 &= \frac{\lambda}{4\pi z \epsilon_o} \frac{L}{\sqrt{(L/2)^2 + z^2}} \\
 &= \frac{1}{4\pi\epsilon_o} \frac{Q}{z \sqrt{\left(\frac{L}{2}\right)^2 + z^2}}
 \end{aligned}$$

This is the field due to a charged rod of length  $L$ .

Note that there are only a few integrals that we can solve in closed form to find electric fields. It might be a good idea to build your own integral table for our exams, including the integrals from the problems and examples we work.

An infinitely long line of charge is one of our basic charge models. So far our line of charge is not infinitely long. We can find the field due to an infinite line of charge by letting  $L$  become large

$$\begin{aligned}
 E_z &= \lim_{L \rightarrow \infty} \frac{1}{4\pi\epsilon_o} \frac{Q}{z \sqrt{\left(\frac{L}{2}\right)^2 + z^2}} \\
 &= \frac{1}{4\pi\epsilon_o} \frac{Q}{z \left(\frac{L}{2}\right)} \\
 &= \frac{1}{4\pi\epsilon_o} \frac{2\lambda}{z} \\
 &= \frac{1}{4\pi\epsilon_o} \frac{2\lambda}{z}
 \end{aligned}$$

or if we use  $r$  now in place of  $z$  to define the distance from the center of the line of charge (so it is easier to compare to our point charge formula), we have

$$\vec{\mathbf{E}}_z = \frac{1}{4\pi\epsilon_o} \frac{2\lambda}{r} \hat{\mathbf{k}}$$

Question 223.23.3

We should get a mental picture of what this means.

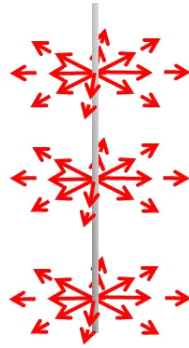

The field around a long line of charge only depends on the distance away from the line, and on the linear charge density. As we would expect, the field gets weaker as we get farther away. But it does not get weaker as fast as the point charge case. That makes some sense, because our infinite line of charge is, well, really big. You are never really too far away from something that is infinitely big. So we should not expect such a charge configuration to look very like a point charge no matter how far away we go. Of course an infinite line of charge is not something we can really build. So this is a useful approximation near, say, a charged wire. But farther from the wire the approximation would not be so good and we would have to go back to our finite line solution.

### Ring of charge

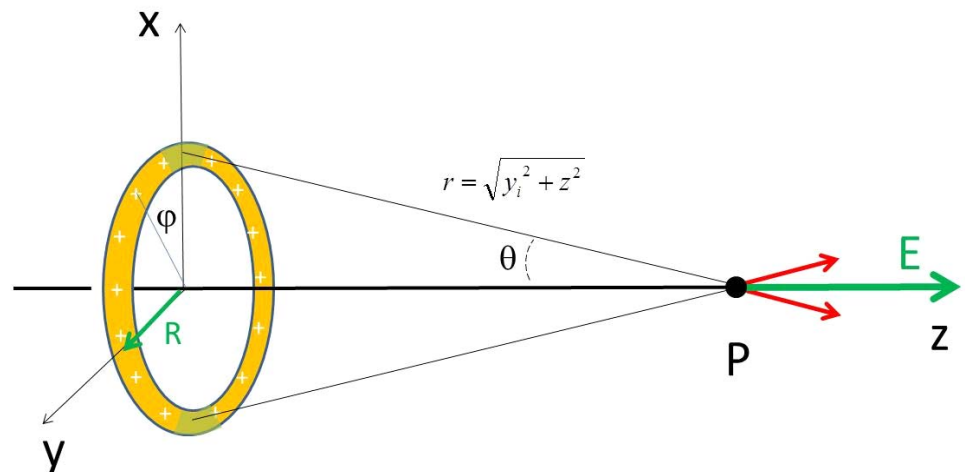



## Question 223.23.4

MIT Visualization:  
Integrating a ring of  
charge

Using what we have learned from the line of charge, we can find the axial field of a ring of charge. Again, our picture is critically important. We will need to solve the problem of eliminating  $\hat{r}$ . From the picture, we can see that we will only have an  $z$ -component again. So we can eliminate  $\hat{r}$  the same way as in the last problem. We model the ring as a line of charge of length  $2\pi R$  that has been bent into a circle. Again we have the basic equation

$$\vec{E} = \frac{1}{4\pi\epsilon_0} \int \frac{dq}{r^2} \hat{r}$$

Since the ring of charge is like a line of charge bent into a hoop. So we can plan to work this problem very like the the line charge. Start again with

$$dq = \lambda dy$$

but now we know that for the hoop

$$dq = \lambda ds$$

where  $s$  is the arc length. Recall that

$$s = R\phi$$

$$ds = R d\phi$$

where  $R$  is the radius of the ring and  $\phi$  is an angle measured from the  $x$ -axis. So our  $dq$  expression becomes

$$dq = \lambda R d\phi$$

For the whole ring

$$Q = \lambda R 2\pi$$

$$= 2\pi R\lambda$$

We also need to use geometry to find  $r$ , the distance to our point were we want to know the field.

$$r = \sqrt{y_i^2 + z^2}$$

but since this is a ring, our  $y_i = R$  for all  $i$ . So

$$r = \sqrt{R^2 + z^2}$$

and using the same reasoning as in our last problem,

$$\cos \theta = \frac{z}{\sqrt{R^2 + z^2}}$$

We need to split our three-dimensional problem into three one-dimensional problems.

We will split our vector equation into  $x$ ,  $y$ , and  $z$  components. But once more, we know from symmetry that only the  $z$ -component will not be zero. Then we can set up our

integral.

$$\begin{aligned} E_z &= \vec{\mathbf{E}} \cdot \hat{\mathbf{k}} \\ &= \frac{1}{4\pi\epsilon_o} \int_{-L/2}^{L/2} \frac{dq}{r^2} \hat{\mathbf{r}} \cdot \hat{\mathbf{k}} \end{aligned}$$

Putting in all the parts we have found yields

$$\begin{aligned} E_z &= \frac{1}{4\pi\epsilon_o} \int \frac{dq}{R^2 + z^2} \frac{z}{\sqrt{R^2 + z^2}} \\ &= \frac{1}{4\pi\epsilon_o} \int \frac{z\lambda R d\phi}{(R^2 + z^2)^{\frac{3}{2}}} \\ &= \frac{z\lambda R}{4\pi\epsilon_o (R^2 + z^2)^{\frac{3}{2}}} \int_0^{2\pi} d\phi \end{aligned}$$

This is an easy integral to do! and we see that the axial field is

$$E_z = \frac{z2\pi R\lambda}{4\pi\epsilon_o (R^2 + z^2)^{\frac{3}{2}}}$$

or, using our form for  $Q$

$$\vec{\mathbf{E}} = \frac{1}{4\pi\epsilon_o} \frac{zQ}{(R^2 + z^2)^{\frac{3}{2}}} \hat{\mathbf{k}}$$

Once again we should check to see if this is a reasonable result. If we take the limit as  $z$  goes to infinity, we get zero. That is comforting. But if we just let  $z$  be much larger than  $R$ , but not too big

$$\begin{aligned} \lim_{z \gg R} \vec{\mathbf{E}} &= \lim_{z \gg R} \frac{1}{4\pi\epsilon_o} \frac{zQ}{(R^2 + z^2)^{\frac{3}{2}}} \hat{\mathbf{k}} \\ &= \frac{1}{4\pi\epsilon_o} \frac{zQ}{(z^2)^{\frac{3}{2}}} \hat{\mathbf{k}} \\ &= \frac{1}{4\pi\epsilon_o} \frac{zQ}{z^3} \hat{\mathbf{k}} \\ &= \frac{1}{4\pi\epsilon_o} \frac{Q}{z^2} \hat{\mathbf{k}} \end{aligned}$$

we again have a point charge field with total charge  $Q$ . Since a ring of charge should look like a point charge if we get far enough away, this is reasonable.

We have worked two problems for continuous charge distributions. The pattern for solving both problems was the same. And we will follow the same pattern for solving for the field from continuous charge distributions in all our problems:

- Start with  $\vec{\mathbf{E}} = \frac{1}{4\pi\epsilon_o} \int \frac{dq_E}{r^2} \hat{\mathbf{r}}$
- Find an expression for  $dq_E$
- Use geometry to find an expression for  $r$ , the distance from  $dq_E$  to the point,  $P$ , where we want to know the field.
- Eliminate  $\hat{\mathbf{r}}$  in the usual way by turning a two or three-dimensional problem into

two or three one-dimensional problems (using vector components, etc.)

- Solve the integral(s) (don't forget to report the direction)

If you have a harder problem, one where you need the field from a continuous charge distribution at a point that is not on an axis, or your problem has little symmetry, you can go back to

$$\begin{aligned}\vec{\mathbf{E}} &\approx \sum_i \Delta \vec{\mathbf{E}}_i \\ &\approx \frac{1}{4\pi\epsilon_o} \sum_i \frac{\Delta q_i}{r_i^2} \hat{\mathbf{r}}_i\end{aligned}$$

and perform the sum numerically. We won't do this in our class, but you might in practice or in a higher level electrodynamics course.

## Basic Equations

The basic equation from this chapter is the equation for finding the field from a distribution of charge

$$\vec{\mathbf{E}} = \frac{1}{4\pi\epsilon_o} \int \frac{dq_E}{r^2} \hat{\mathbf{r}}$$

The process for using this equation is

- Start with  $\vec{\mathbf{E}} = \frac{1}{4\pi\epsilon_o} \int \frac{dq_E}{r^2} \hat{\mathbf{r}}$
- Find an expression for  $dq_E$
- Use geometry to find an expressions for  $r$
- Break the two or three-dimensional problem into two or three one-dimensional problems.
- Solve the integral(s) (don't forget to report the direction)



# 5 Motion of Charged Particles in Electric Fields

## Fundamental Concepts

- The capacitor
- Field of an ideal Capacitor
- Motion of particles in a constant electric field

## Sheet of Charge

Question 223.23.5

Let's try a two dimensional distribution of charge, a uniform flat sheet of charge. We will assume that the sheet is infinitely large (so we don't have to deal with what happens at the edges). Let's call the surface charge density  $\eta = Q/A$  where  $Q$  is the total charge and  $A$  is the total area. Of course, we can't calculate this surface charge density directly from the totals, because they are infinite. But we could take a square meter of area and find the amount of charge in that small area. The ratio should be the same for any area so long as  $\eta$  is uniform. We will find the electric field to the right of the sheet at point  $P$ .

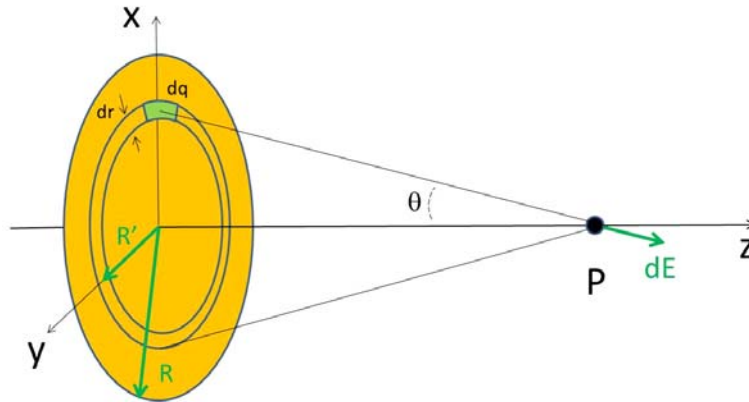

Once again we start with

$$\vec{E} = \frac{1}{4\pi\epsilon_0} \int \frac{dq}{r^2} \hat{r}$$

We need to find  $dq$ , an expression for  $r$ , and get rid of  $\hat{r}$

Since the disk is uniformly charged, then, knowing the surface charge density

$$\eta = \frac{Q}{A}$$

we can find the total amount of charge for an area

$$Q = \eta A$$

so

$$dq = \eta dA$$

but what area,  $dA$ , should we use? Notice the green patch in the figure that is marked  $dA$ . Think for a moment about arc length

$$s = R\phi$$

This little area is about  $ds = R d\phi$  long, and about  $dR$  wide. If we let  $dA$  be small enough, this is exact. So

$$dA = R d\phi dR$$

Then our  $dq$  is just  $\eta$  times this

$$dq = \eta R d\phi dR$$

From geometry we identify

$$r = \sqrt{z^2 + R^2}$$

and, due to symmetry we expect only the  $z$ -component of the field to survive. So to get rid of  $\hat{r}$  we multiply (dot product) by  $\hat{k}$ . There will be an angle,  $\theta$ , between  $\hat{r}$  and  $\hat{k}$ . So

we expect the result of the dot product to be that we multiply by the cosine of  $\theta$

$$\cos \theta = \frac{z}{\sqrt{z^2 + R^2}}$$

We want to put all this into our basic equation. This time the radius  $R$  changes, so let's call it  $R'$  so we recognize that it is a variable over which we must integrate. We split our integral equation into components, so

$$\vec{\mathbf{E}} = \frac{1}{4\pi\epsilon_0} \int \frac{dq}{r^2} \hat{\mathbf{r}}$$

becomes

$$E_x = \frac{1}{4\pi\epsilon_0} \int \frac{\eta R d\phi dR'}{(z^2 + R'^2)} \hat{\mathbf{r}} \cdot \hat{\mathbf{i}}$$

$$E_y = \frac{1}{4\pi\epsilon_0} \int \frac{\eta R d\phi dR'}{(z^2 + R'^2)} \hat{\mathbf{r}} \cdot \hat{\mathbf{j}}$$

and

$$E_z = \frac{1}{4\pi\epsilon_0} \int \frac{\eta R d\phi dR'}{(z^2 + R'^2)} \hat{\mathbf{r}} \cdot \hat{\mathbf{k}}$$

$$= \frac{1}{4\pi\epsilon_0} \int \frac{\eta R d\phi dR'}{(z^2 + R'^2)} \cos \theta$$

and we will integrate from  $R' = 0$  to  $R' = R$ .

Note that from our symmetry we can argue that  $E_x$  and  $E_y$  must be zero, so we only need to calculate

$$E_z = \frac{1}{4\pi\epsilon_0} \int_0^{2\pi} \int_0^R \frac{z\eta R' d\phi dR'}{(z^2 + R'^2)^{\frac{3}{2}}}$$

Performing the integration over  $d\phi$  just gives us a factor of  $2\pi$

$$E_z = \frac{z\pi\eta}{4\pi\epsilon_0} \int_0^R \frac{2R' dR'}{(z^2 + R'^2)^{\frac{3}{2}}}$$

where, for convenience, we have left the 2 inside the integral (it will be useful later).

We need to solve this integral. A  $u$ -substitution is one way. Suppose we let

$$u = z^2 + R'^2$$

so

$$du = 2R' dR'$$

We will need to adjust the limits of integration, for  $R' = 0$  we have

$$u = z^2$$

and for  $R' = R$

$$u = z^2 + R^2$$

then our integral becomes

$$E_z = \frac{z\pi\eta}{4\pi\epsilon_o} \int_{z^2}^{z^2+R^2} \frac{du}{(u)^{\frac{3}{2}}}$$

We get

$$\begin{aligned} E_z &= \frac{z\pi\eta}{4\pi\epsilon_o} \left[ \frac{-2}{(u)^{\frac{1}{2}}} \right]_{z^2}^{z^2+R^2} \\ &= \frac{z\pi\eta}{4\pi\epsilon_o} \left( \frac{-2}{(z^2+R^2)^{\frac{1}{2}}} - \frac{-2}{(z^2)^{\frac{1}{2}}} \right) \\ &= \frac{-2z\pi\eta}{4\pi\epsilon_o} \left( \frac{1}{(z^2+R^2)^{\frac{1}{2}}} - \frac{1}{z} \right) \\ &= \frac{-2\pi\eta}{4\pi\epsilon_o} \left( \frac{z}{(z^2+R^2)^{\frac{1}{2}}} - 1 \right) \\ &= \frac{-2\pi\eta}{4\pi\epsilon_o} \left( \frac{1}{\frac{1}{z}(z^2+R^2)^{\frac{1}{2}}} - 1 \right) \end{aligned}$$

The result is

$$E_z = \frac{2\pi\eta}{4\pi\epsilon_o} \left( 1 - \frac{1}{\left(1 + \frac{R^2}{z^2}\right)^{\frac{1}{2}}} \right)$$

or

$$E_z = \frac{2\pi\eta}{4\pi\epsilon_o} \left( 1 - \left(1 + \frac{R^2}{z^2}\right)^{-\frac{1}{2}} \right)$$

This looks messy, but this is the answer.

But wait, this is really a disk of charge with radius  $R$ . We wanted an infinite sheet of charge. So, suppose we let  $R$  get very big. Then

$$\begin{aligned} E_{R \rightarrow \infty} &= \lim_{R \rightarrow \infty} \frac{2\pi\eta}{4\pi\epsilon_o} \left( 1 - \left(1 + \frac{R^2}{z^2}\right)^{-\frac{1}{2}} \right) \\ &= \frac{2\pi\eta}{4\pi\epsilon_o} \\ &= \frac{\eta}{2\epsilon_o} \end{aligned}$$

Question 223.23.6

This is the field for our semi-infinite sheet of charge.

We should take some time to figure out if this makes sense.

This sheet cuts the entire universe into two parts. It is so big, that it is hard to say anything is very far away from it. So we can understand this answer, The field from such a sheet of charge is constant everywhere in all of space. No matter how far away



we get, it will never look like a point charge, in fact, it never really looks any farther away!

Note we did just one side of the sheet, there is a matching field on the other side. So this sheet of charge fills all of space with a constant field.

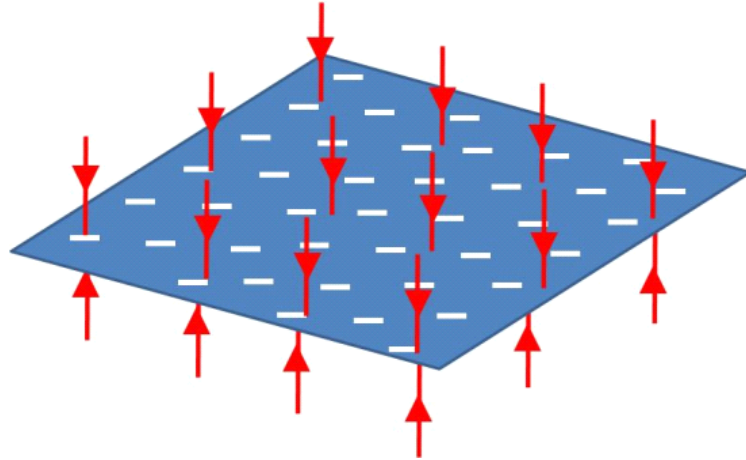

of course this is not physically possible to build, but we will see that if we look at a large sheet of charge, like the plate of a capacitor, that near the center, the field approaches this limit, because the sides of the sheet are far away.

Visualization  
falstad 3D

Let's go back and consider the disk of charge.

$$E_z = \frac{2\pi\eta}{4\pi\epsilon_o} \left( 1 - \left( 1 + \frac{R^2}{z^2} \right)^{-\frac{1}{2}} \right)$$

Suppose we look at this distribution from vary far away for a finite disk. We expect that it should look like a point charge with total charge  $Q$ . Let's show that this is true. When  $z$  gets very large  $R/z$  is very small.

$$E_{z \gg R} = \frac{2\pi\eta}{4\pi\epsilon_o} \left( 1 - \left( 1 + \frac{R^2}{z^2} \right)^{-\frac{1}{2}} \right)$$

Let's look at just the part

$$\left( 1 + \frac{R^2}{z^2} \right)^{-\frac{1}{2}}$$

This is of the form  $(1 + x)^n$  where  $x$  is a small number. We can use the binomial expansion

$$(1 + x)^n \approx 1 + nx \quad x \ll 1$$

to write this as

$$\left(1 + \frac{R^2}{z^2}\right)^{-\frac{1}{2}} \approx 1 - \frac{1}{2} \frac{R^2}{z^2}$$

so in the limit that  $z$  is large we have

$$\begin{aligned} E_{z \gg R} &= \frac{2\pi\eta}{4\pi\epsilon_o} \left(1 - 1 + \frac{1}{2} \frac{R^2}{z^2}\right) \\ &= \frac{1}{4\pi\epsilon_o} \frac{\pi \frac{Q}{\pi R^2} R^2}{z^2} \\ &= \frac{1}{4\pi\epsilon_o} \frac{Q}{z^2} \end{aligned}$$

Which looks like a point charge as we expected. We have just a small, disk of charge very far away. That is looks like a point charge with total charge  $Q$ .

### Spheres, shells, and other geometries.

I won't do the problem for the field of a charged sphere or spherical shell. We could, but we will save them for a new technique for finding fields from configurations of charge that we will learn soon. This new technique will attempt to make the integration much easier.

## Constant electric fields

Let's try to use what we know about electric fields to predict the motion of charged particles that are placed in electric fields. We will start with the simplest case, a charged particle moving in a constant electric field. Before we take on such a case, we should think about how we could produce a constant electric field.

We know that a semi-infinite sheet of charge produces a constant electric field. But we realize that a semi-infinite object is hard to build and hard to manage. But if the size of the sheet of charge is very large compared to the charge size, using our solution for a semi-infinite case might not be too bad if we are away from the edges of the real sheet.

We want to study just such a device. In fact we will use two finite sheets of charge.

### Capacitors

From what we know about charge and conductors, we can charge a large metal plate by touching it to something that is charged, like a rubber rod, or a glass rod that has been

rubbed with the right material.

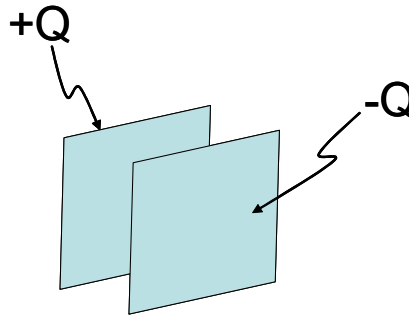

If we have two large metal plates and touch one with a rubber rod and one with a glass rod, we get two oppositely charged sheets of charge.

What would the field look like for this oppositely charged set of plates? Here is one of our thread-in-oil pictures of just such a situation. We are looking at the plates edge-on.

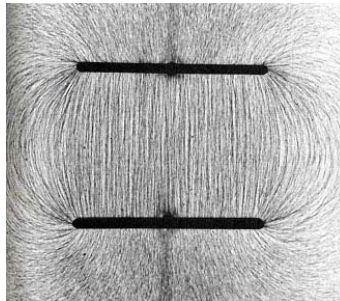
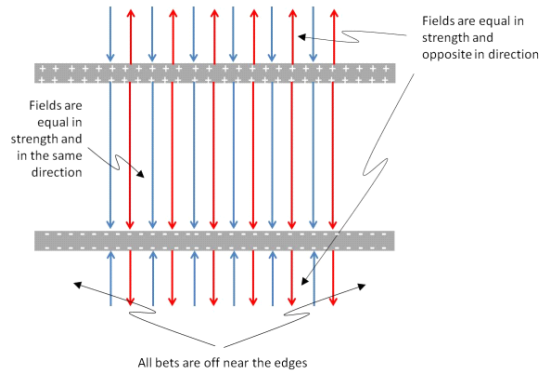

Figure 5.3. [http://stargazers.gsfc.nasa.gov/images/geospace\\_images/electricity/charged\\_plates.jpg](http://stargazers.gsfc.nasa.gov/images/geospace_images/electricity/charged_plates.jpg)

Near the center, the field is close to constant. Near the sides it is not so much so. We are probably justified in saying the field in the middle is nearly constant. A look at the field lines shows us why



Note that in between the plates, the electric field from the positive plate is downward. But so is the electric field from the negative plate. The two fields will add together. Outside the plates, the field from one plate is in the opposite direction from that of the other plate. The two fields will nearly cancel. If our device is made of semi-infinite sheets of charge, they will precisely cancel, because the field of a semi-infinite sheet of charge is uniform everywhere.

We call this configuration of two charged plates a *capacitor* and, as you might guess, this type of device proves to be more useful than just making nearly constant fields. It is a major component in electronic devices. Before we can build an iPad or a laptop, we will need to understand several different types of basic devices. This set of charged plates is our first.

Of course, for real capacitors, the fields outside cancel completely only near the center of the plates. Near the edges, the direction of the fields will change, and we get the sort of behavior that we see in figure 5.3 near the edges.

It is probably worth noting that outside the capacitor the field has a *magnitude of zero* (or nearly zero). It is not really correct to say that there is no field. In fact, there are two superimposed fields, or alternately, a field from each of the charges on each plates, all superimposed. The fields are there, but their magnitude is zero.

In the middle, then, we will have

$$\begin{aligned}
 E &= E_+ + E_- \\
 &\approx \frac{\eta}{2\epsilon_o} + \frac{\eta}{2\epsilon_o} \\
 &= \frac{\eta}{\epsilon_o} \\
 &= \frac{Q}{A\epsilon_o}
 \end{aligned}$$

## Particle motion in a uniform field

Question 223.24.1

Now that we have a way to form a uniform electric field as our environment, we can study charged particles moving in this field. And this is really something we are familiar with. It is very much like a ball in a uniform gravitational field. But we have the complication of having two different types of charge. The force on such a particle is given by

$$\vec{\mathbf{F}} = q_m \vec{\mathbf{E}}$$

but we can combine this with Newton's second law

$$\vec{\mathbf{F}} = m \vec{\mathbf{a}}$$

to find the particle's acceleration

$$\vec{\mathbf{a}} = \frac{q_m \vec{\mathbf{E}}}{m}$$

CRT Demo

Note, this is NOT true in general. It is only true for constant electric fields.

## Millikan

Let's try a problem. Perhaps you have wondered, "how do we know that charge comes in packets of the size of the electron charge?" This is a good story, and uses many of the laws we have learned.

Robert Millikan devised a clever device in the early 1900's. A picture of his device is given below.

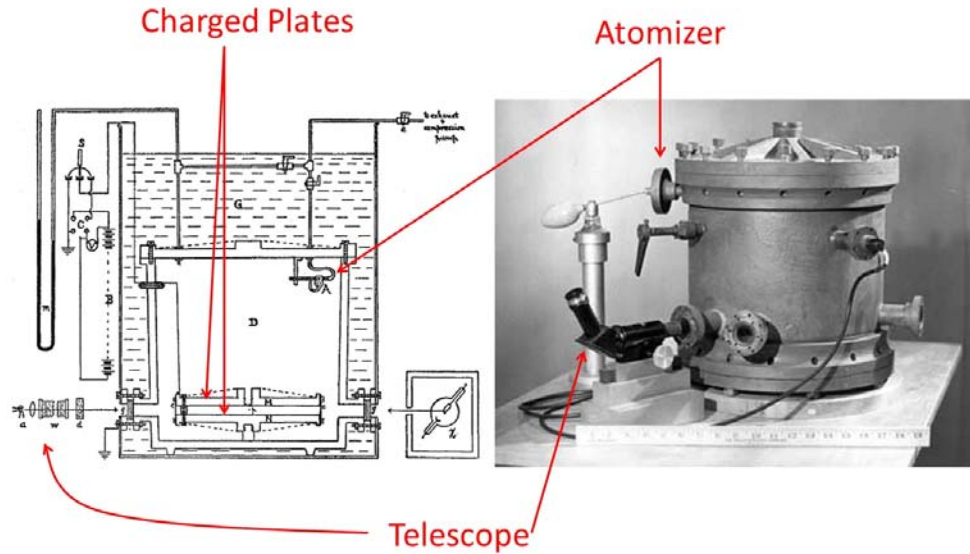

Millikan's oil-drop apparatus: Diagram taken from original Millikan's paper, 1913,  
Image taken in 1906 (Both Images in the Public Domain)  
Schematically we can draw the experiment like this.

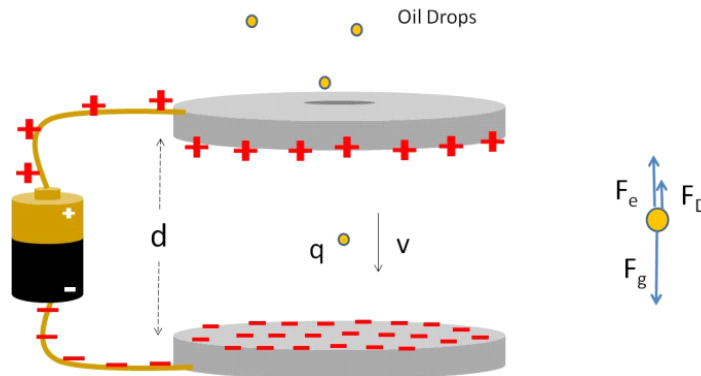

Millikan made negatively charged oil drops with an atomizer (fine spray squirt bottle). The drops are introduced between two charged plates into what we know is essentially a constant electric field. A light shines off the oil drops, so you can see them through a telescope (not shown). We can determine the motion of the oil drops just like we did in PH121 or Dynamics. If the upper plate has the positive charge, then the electric field  $\vec{E}$  is downward. A free body diagram for a drop is shown in the figure to the left of the apparatus. We can write out Newton's second law for the drop (our mover charge).

$$F_{net,y} = m_d a_y = -F_g \pm F_D + F_e$$

where  $F_D$  is a drag force because we have air resistance.

If the upper plate has the positive charge, then the electric field  $\vec{E}$  is downward. So

$$\vec{F}_e = -q_m \vec{E}$$

The field points down, the charge is negative, so the force is upward (positive in our favorite coordinate system). We can write Newton's second law as

$$m_d a_y = -F_g \pm F_D + qE$$

If  $F_e$  is large enough, we can make the oil drop float up! Then the drag force is downward

$$m_d a_y = -mg - F_D + qE$$

and if we are very careful, we can balance these forces so we have the drop float upward at a small constant velocity.

$$0 = -mg - F_D + qE$$

The constant speed is really slow, hundredths of a centimeter per second. so we can watch the drop move with no problem (except for patience). Once he achieved a constant speed, by knowing the drop size and density Millikan could calculate the mass, and therefore the charge.

$$mg + F_D = q_m E$$

we see that

$$q_m = \frac{mg + F_D}{E}$$

Which is where our problem ends. But Millikan went farther. He had actual data, so he could compare charges on different droplets. He found that no matter what the value for  $q_m$ , it was a multiple of a value,  $q_e = 1.602 \times 10^{-19}$  C. So

$$q_m = nq_e \quad n = 0, \pm 1, \pm 2, \dots$$

to within about 1%.<sup>8</sup> So the smallest charge the drops could have added to them was  $1 \times q_e$  and any other larger charge would be a larger multiple of  $q_e$ . The conclusion is that charge comes in units of  $q_e$ . We recognize  $q_e$  as the electron charge. You can't add half of an electron charge. This experiment showed that charge seems to only come in whole units!

## Free moving particles

<sup>8</sup> There is actually some controversy about this. Apparently Millikan and his students threw out much of their data, keeping only data on drops that behaved like they thought they should. They were lucky that this poor analysis technique did not lead to invalid results! (William Broad and Nicholas Wade, *Betrayers of the truth*, Simon and Schuster, 1983)

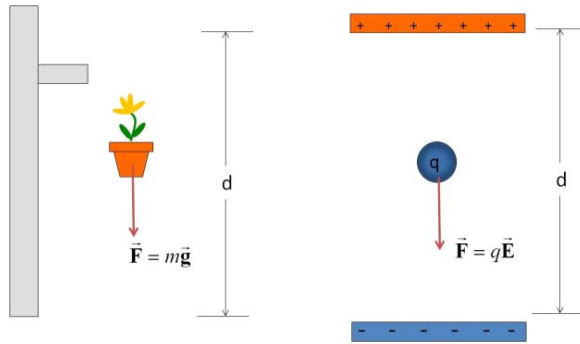

We may recall that for an object falling in a gravitational field, say, near the Earth's surface, the acceleration,  $g$ , is nearly constant. If we have a charge moving in a constant electric field, we have a constant acceleration. From Newton's second law,

$$ma = q_m E$$

we can see that this acceleration is

$$a = \frac{q_m E}{m}$$

From our Dynamics or PH121 experience, we have a set of equations to handle problems that involve constant acceleration

$$\begin{aligned} x_f &= x_i + v_{ix}t + \frac{1}{2}a_x t^2 \\ v_{xf} &= v_{xi} + a_x t \\ v_{xf}^2 &= v_{xi}^2 + 2a_x \Delta x \end{aligned}$$

and

$$\begin{aligned} y_f &= y_i + v_{iy}t + \frac{1}{2}a_y t^2 \\ v_{yf} &= v_{yi} + a_y t \\ v_{yf}^2 &= v_{yi}^2 + 2a_y \Delta y \end{aligned}$$

These are known as the *kinematic equations*. You derived them if you took Dynamics (or derived them and then memorized them if you took PH121). Let's try a brief problem. Suppose we have a positive charge in a uniform electric field as shown.



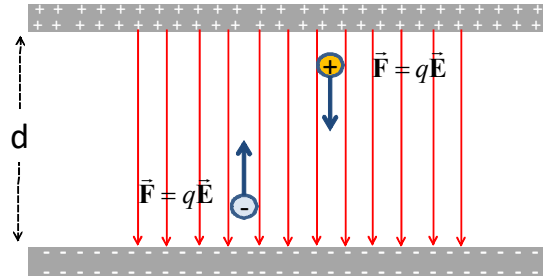

Let  $y = 0$  at the positive plate. How fast will the particle be going as it strikes the negative plate?

We use the acceleration

$$a_y = \frac{q_m E}{m}$$

$$a_x = 0$$

For this problem we don't have any  $x$ -motion, So we can limit ourselves to.

$$y_f = y_i + v_{iy}t + \frac{1}{2} \left( \frac{q_m E}{m} \right) t^2$$

$$v_{yf} = v_{yi} + \left( \frac{q_m E}{m} \right) t$$

$$v_{yf}^2 = v_{yi}^2 + 2 \left( \frac{q_m E}{m} \right) \Delta y$$

We don't have the time of flight of the particle, but we can identify

$$\Delta y = d$$

The particle started from rest, so

$$v_{yo} = 0$$

Therefore it makes sense to use the last of the three equations, because we know everything that shows up in this equation but the final speed, and that is what we want to find.

$$v_{yf}^2 = v_{yi}^2 + 2 \left( \frac{q_m E}{m} \right) \Delta y$$

$$v_{yf}^2 = 0 + 2 \left( \frac{q_m E}{m} \right) d$$

$$v_{yf} = \sqrt{\frac{2q_m E d}{m}}$$

There is a complication, however. With gravity, we only have one kind of mass. But with charge we have two kinds of charge. Suppose we have a negative particle.

Of course the negative particle would not move if it was started from the positive side. It would be attracted to the positive plate. But suppose we start the negative particle from the negative plate. It would travel “up” to the positive plate. We defined the downward direction as the positive  $y$ -direction without really thinking about it. Now we realize that the upward direction must be opposite, so upward is the negative  $y$ -direction. Our negative particle will experience a displacement  $\Delta y = -d$ .

Then

$$v_{yf}^2 = v_{yi}^2 + 2 \left( \frac{-q_m E}{m} \right) \Delta y$$

$$v_{yf}^2 = 0 + 2 \left( \frac{-q_m E}{m} \right) (-d)$$

$$v_{yf} = \sqrt{\frac{2q_m E d}{m}}$$

we get the same speed, but this illustrates that we will have to be careful to watch our signs.

In this last problem we have had only an electric force, no gravitational force. This is important to notice. If there were also a gravitational force, we would need to use Newton’s second law to add up the forces like we did with the Millikan problem.

Let’s take another example. This time let’s send in a negatively charged particle horizontally through the capacitor. The particle will move up due to the electric field force. How far up will it go as it travels across the center of the capacitor?

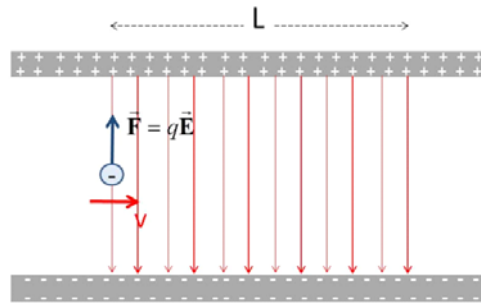

Let’s define the starting position as

$$x_i = 0$$

$$y_i = 0$$

We can identify that

$$v_{ix} = v_0$$

$$v_{iy} = 0$$

And that

$$\begin{aligned} a_y &= \frac{q_m E}{m} \\ a_x &= 0 \end{aligned}$$

We can fill in these values in our kinematic equations

$$\begin{aligned} x_f &= 0 + v_o t + \frac{1}{2} (0) t^2 \\ v_{xf} &= v_o + (0) t \\ v_{xf}^2 &= v_o^2 + 2 (0) \Delta x \end{aligned}$$

and

$$\begin{aligned} y_f &= 0 + (0) t + \frac{1}{2} \left( \frac{q_m E}{m} \right) t^2 \\ v_{yf} &= (0) + \left( \frac{q_m E}{m} \right) t \\ v_{yf}^2 &= (0) + 2 \left( \frac{q_m E}{m} \right) (y_f - 0) \end{aligned}$$

From the first set we see that  $v_{xf} = v_o$ , that is, the  $x$ -direction velocity does not change. That makes sense because we have no force component in the  $x$ -direction.

After  $t$  seconds we see that the charged particle has traveled a distance

$$x_f = v_o t$$

If we measure  $x_f = L$  then we can see how long it took for the particle to travel through the capacitor

$$t = \frac{L}{v_o}$$

Now let's look at the deflection. We can use the first equation of the  $y$ -set

$$\begin{aligned} y_f &= \frac{1}{2} \left( \frac{q_m E}{m} \right) t^2 \\ &= \frac{1}{2} \left( \frac{q_m E}{m} \right) \left( \frac{L}{v_o} \right)^2 \end{aligned}$$

Let's see if this makes sense. If the electric field gets larger, the particle will deflect more.

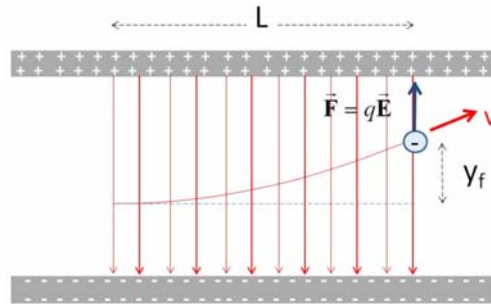

This is right. The field causes the force, so more field gives more effect from the force. If we increase the charge, the deflection grows since the force depends on the charge of the moving particle. This also seems reasonable. If the mass increases, it is harder to move the particle, so it makes sense that a larger mass makes a smaller deflection. If the particle is in the field longer, the deflection will increase, so the dependence on  $L$  makes sense. Finally, if the initial speed is larger the particle spends less time in the field, so the deflection will be less.

### Non uniform fields

Of course all of this depends on the field being uniform. For a non uniform field the force is still

$$\vec{F} = q\vec{E}(x, y, z)$$

but now the field is a function of position. This makes for a more difficult problem. For now we will stick to constant fields. If we had to take on a non-uniform field, we would likely use a numerical technique.

### Basic Equations

The magnitude of the electric field due to a disk of charge along the disk's axis

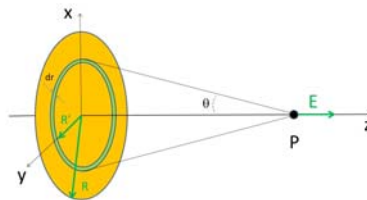

$$E_z = \frac{2\pi\eta}{4\pi\epsilon_o} \left( 1 - \left( 1 + \frac{R^2}{z^2} \right)^{-\frac{1}{2}} \right)$$

The magnitude of the electric field due to a semi-infinite sheet of charge

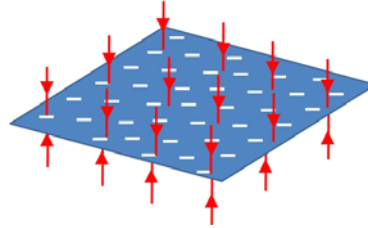

$$E = \frac{\eta}{2\epsilon_o}$$

The magnitude of the electric field inside an ideal capacitor

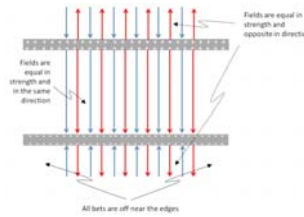

$$E = \frac{Q}{A\epsilon_o}$$

Motion of a charged particle in a constant electric field

$$\vec{a} = \frac{q\vec{E}}{m}$$

$$\begin{aligned} x_f &= x_i + v_{ix}t + \frac{1}{2}a_x t^2 & y_f &= y_i + v_{iy}t + \frac{1}{2}a_y t^2 \\ v_{xf} &= v_{xi} + a_x t & v_{yf} &= v_{yi} + a_y t \\ v_{xf}^2 &= v_{xi}^2 + 2a_x \Delta x & v_{yf}^2 &= v_{yi}^2 + 2a_y \Delta y \end{aligned}$$



# 6 Dipole motion, Symmetry

## Fundamental Concepts

- Force and torque on a dipole in a uniform field
- Force on a dipole in a non-uniform field
- Drawing the shape of a field using symmetry

This lecture combines two topics that might be better separated. The first relates to forces on charges in uniform fields. This is what we discussed last lecture. The next is the beginning of the ideas that will allow us to use symmetry and geometry to avoid integration over charges. But because our lecture times are only an hour, and we can only do so much at once, they are combined here together. But they form a nice transition between the two topics this way. We will first study the motion of dipoles in uniform, and not so uniform fields. We will find symmetry and geometry plays a part in our solutions. Then we will study the fields of standard symmetric objects.

## Dipole motion in an electromagnetic field

We remember dipoles, a pair of charges of equal magnitude but opposite in charge, bound together at set separation distance. Let's take our environment to be a constant electric field, and our mover to be a dipole.



Question 223.25.1

Here is a diagram of the situation.

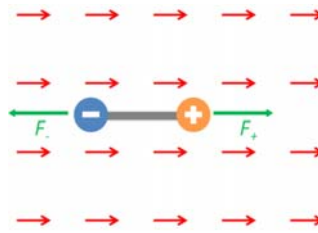

Notice that as usually, just the environmental field is drawn. There is a field from the dipole, too,

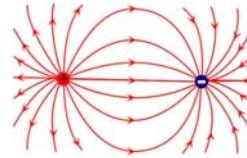

but this is the mover's self-field and it cannot create a force on the dipole, so we will not draw it. Of course, if we introduce yet another charge,  $q_{new}$ , the environmental field this new charge would feel would be a combination of both the dipole field and the uniform field! We would have to draw the superposition of the two fields.

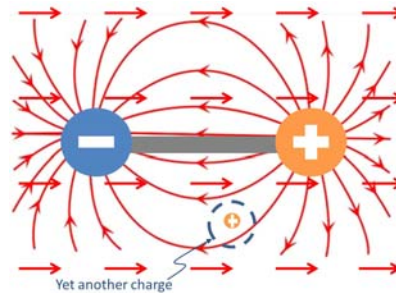

But that is a different problem!

Here is our case again. We only draw the environmental field that will cause the motion of the mover object we are studying.

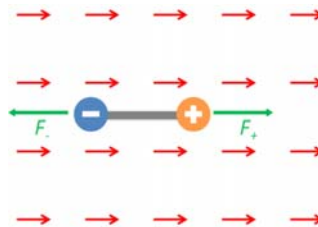

To understand these figures, we have to remember that the red field arrows are an *external field* that is, the dipole is not making this field. something else must be. We did not draw that something else. Since it is a uniform field, it is probably a capacitor. Here is what it might look like



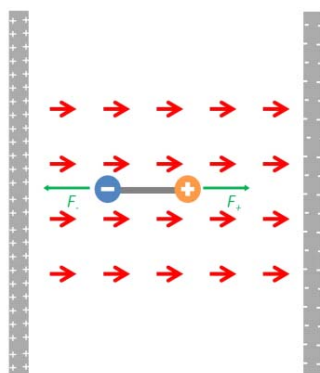

The positive side must be to the left, because the red external field arrows come from the left. The negative side must be to the right, because the field arrows are pointed that direction. We can get away with not drawing the source of the external field because the force on the dipole charges is just

$$\vec{F} = q_m \vec{E}$$

If we know  $\vec{E}$ , then we don't need any information about it's source to find the force. Since the field is the environment that the mover charges feel, the field is enough. Let's find the net force on the dipole due to the environmental field.

Question 223.25.2

We use Newton's second law to find that

$$F_{net_x} = -F_- + F_+ = ma_x$$

and our definition of the electric field to find

$$F_- = q_- E$$

$$F_+ = q_+ E$$

so since  $|q_-| = |q_+| = q$

$$-qE + qE = ma_x$$

which tells us that there is no acceleration, no net force. The center of mass of a dipole does not accelerate in a uniform field. But we remember from PH121 that we can make things rotate.

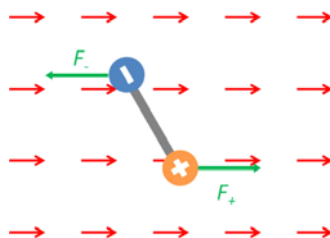

If the dipole is not aligned with it's axis in the field direction, then the forces will cause a torque.

Question 223.25.3

We remember that torque is given by

$$\vec{\tau} = \vec{r} \times \vec{F}$$

substituting in our force and defining the distance between the charges to be  $a$  we can write this out

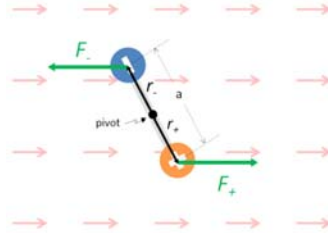

The magnitude of the torque is given by

$$|\tau| = rF \sin \theta$$

where  $\theta$  is the angle between  $\mathbf{r}$  and  $\mathbf{F}$ . It is easier to find that angle if we redraw each displacement vector from the pivot and each force with their tails together

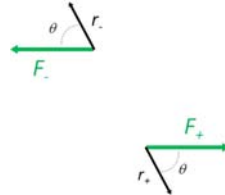

Then for one charge, say,  $q_-$

$$\tau = \frac{a}{2} q E \sin \theta$$

We use the right-hand-rule that you learned in Dynamics or PH121 to find the direction. We can see that the direction will be out of the page. But we have two charges, so we have a torque from each charge. A quick check with the right-hand-rule for torques will convince us that the direction for the torque due to  $q_+$  is also out of the page, and the magnitude is the same, so our total torque is

$$\begin{aligned} \tau_{net} &= \tau_+ + \tau_- \\ &= aqE \sin \theta \end{aligned}$$

Question 223.25.4

which we can write as

$$\tau_{net} = pE \sin \theta$$

or the *dipole moment*,  $p$ , multiplied by  $E \sin \theta$ . Recalling the form of a cross product

$$\vec{A} \times \vec{B} = AB \sin \theta \hat{n}$$

where  $\hat{n}$  is perpendicular to both  $\vec{A}$  and  $\vec{B}$ , we have a hint that we could write our torque as a cross product. We would have to make  $p$  a vector, though. So let's define  $\vec{p}$  as a vector with magnitude  $aq$  and make its direction along the line connecting the charge centers, with the direction from negative to positive.

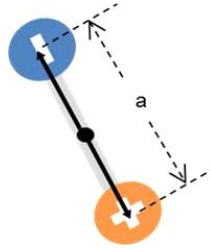

Then we can write the torque as

$$\vec{\tau} = \vec{p} \times \vec{E} \quad (6.1)$$

which is our form for the torque on a dipole.

Let's try a problem. Let's find the maximum angular acceleration for a dipole.

Recall that Newton's second law for rotational motion is

$$\Sigma\tau = I\alpha$$

where  $I$  is the moment of inertia and  $\alpha$  is the angular acceleration. Then we can find how the dipole will accelerate

$$\alpha = \frac{\tau_{net}}{I}$$

For a dipole,  $I$  is simple

$$\begin{aligned} I &= m_- r_-^2 + m_+ r_+^2 \\ &= m \left(\frac{a}{2}\right)^2 + m \left(\frac{a}{2}\right)^2 \\ &= \frac{1}{2} m a^2 \end{aligned}$$

so our acceleration is

$$\begin{aligned} \alpha &= \frac{pE \sin \theta}{\frac{1}{2} m a^2} \\ &= \frac{2pE \sin \theta}{m a^2} \end{aligned}$$

Suppose we look at this for a water molecule in a microwave oven. What is the maximum angular acceleration experienced by the water molecule if the oven has a field strength of  $E = 200 \text{ V/m}$ ?

The dipole moment for a water molecule is something like

$$p_w = 6.2 \times 10^{-30} \text{ C m}$$

and the separation between the charge centers is something like

$$a = 3.9 \times 10^{-12} \text{ m}$$

and the molecular mass of water is

$$M = 18 \frac{\text{g}}{\text{mol}}$$

which is

$$M = mN_A$$

so the mass of a water molecule is

$$\begin{aligned} m &= \frac{M}{N_A} = \frac{18 \frac{\text{g}}{\text{mol}}}{6.022 \times 10^{23} \frac{1}{\text{mol}}} \\ &= 2.989 \times 10^{-26} \text{ kg} \end{aligned}$$

then when  $\sin \theta = 1$  we will have a maximum

$$\begin{aligned} \alpha &= \frac{2(6.2 \times 10^{-30} \text{ C m})(200 \text{ V/m})}{(2.989 \times 10^{-26} \text{ kg})(3.9 \times 10^{-12} \text{ m})^2} \\ &= 5.455 \times 10^{21} \frac{\text{rad}}{\text{s}^2} \end{aligned}$$

Our numbers were kind of rough estimates, but still the result is amazing. Imagine if this happened inside of you! which is why we really should be careful with microwave ovens and microwave equipment.

### Induced dipoles

Suppose that we place a large insulator in a uniform electric field.

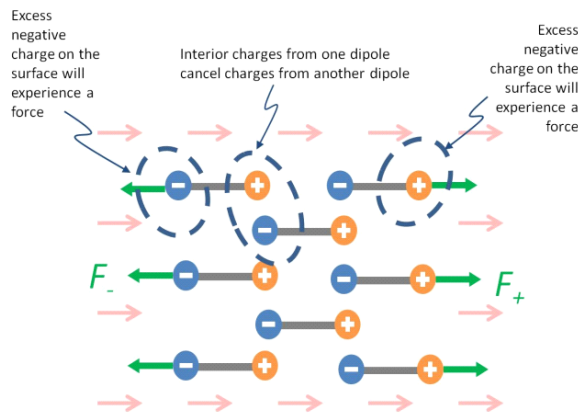

The atoms tend to polarize and become dipoles. We say we have *induced* dipoles within the material. Notice that in the middle of the conductor there is still no net charge. But because we have made the atoms into dipoles, one side of the insulator becomes negatively charged and the other side becomes positively charged. This does not create a net force, but we will find that separating the charges like this can be useful in building capacitors.

### Non-uniform fields and dipoles

Suppose we place our dipole in a non-uniform field? Of course the result will depend on the field, so let's take an example. Let's place a dipole in the field due to a point charge.

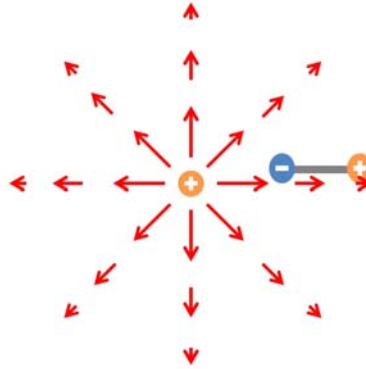

We can see that the field is much weaker at the location of the positive charge than it is at the negative charge location. If we zoom in on the location near our dipole we can see that now we will have an acceleration!

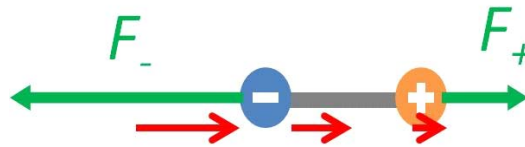

$$\Sigma F_x = -F_- + F_+ = ma_x$$

so

$$-qE_{\text{large}} + qE_{\text{small}} = ma_x$$

Let's go back to our charged balloon from many lectures ago. We found that the charge "leaked off" our balloon. We can see why now. The water molecules in the air are attracted to the charges, and stick to them. When the water molecules float off, they will take our charge with them. We can calculate the net force easily with our field from a dipole that we found earlier,

$$\vec{E}_y = \frac{2}{4\pi\epsilon_o} \frac{\vec{p}}{L^3}$$

then the force on the electron on the balloon is

$$\begin{aligned} F &= q_e E \\ &= \frac{2q_e}{4\pi\epsilon_o} \frac{p}{L^3} \end{aligned}$$

So if the dipole is about a 0.01 cm away

$$\begin{aligned} F &= \frac{2(1.602 \times 10^{-19})}{4\pi(8.85 \times 10^{-12} \frac{\text{C}^2}{\text{N m}^2})} \frac{6.2 \times 10^{-30} \text{ C m}}{(0.01 \text{ cm})^3} \\ &= 1.7862 \times 10^{-26} \text{ N} \end{aligned}$$

But wait! we used the dipole as the environmental object and the single charge as the mover. So this is the force on the single charge! But by Newton's third law, the force on the dipole due to the electron must have the same magnitude and opposite direction so

$$F_{dipole} = -1.7862 \times 10^{-26} \text{ N}$$

We could also use Coulomb's law for a point charge, since we know the field equation. Taking the point charge as the environmental charge and the dipole charges as the movers,

$$\begin{aligned} -qE_{\text{large}} + qE_{\text{small}} &= ma_x \\ -q \left( \frac{1}{4\pi\epsilon_o} \frac{Q}{r_-^2} \right) + q \left( \frac{1}{4\pi\epsilon_o} \frac{Q}{r_+^2} \right) &= ma_x \end{aligned}$$

or

$$\frac{Qq}{4\pi\epsilon_o} \left( \frac{1}{r_+^2} - \frac{1}{r_-^2} \right) = ma_x = F_{net}$$

this is the net force on a dipole due to the point charge.

From our estimations, the effective charge on one side of the water molecule is

$$\begin{aligned} q &= \frac{p}{a} = \frac{6.2 \times 10^{-30} \text{ C m}}{3.9 \times 10^{-12} \text{ m}} \\ &= 1.5897 \times 10^{-18} \text{ A s} \end{aligned}$$

(how can this be true?) so if the dipole is about a 0.01 cm away then

$$\begin{aligned} F_{net} &= \frac{(1.0 \times 10^{-19})(1.5897 \times 10^{-18} \text{ A s})}{4\pi(8.85 \times 10^{-12} \frac{\text{C}^2}{\text{N m}^2})} \\ &\times \left( \frac{1}{\left(0.01 \text{ cm} + \frac{3.9 \times 10^{-12} \text{ m}}{2}\right)^2} - \frac{1}{\left(0.01 \text{ cm} - \frac{3.9 \times 10^{-12} \text{ m}}{2}\right)^2} \right) \\ &= -1.1150 \times 10^{-26} \text{ N} \end{aligned}$$

We expect the negative sign, both forces should be to the left. The answers are different, but within one order of magnitude. This is pretty good since for our dipole field we assumed that the distance from the dipole is very large and 0.01 cm is a somewhat shorter version of very large!

## Symmetry

The symmetry of the uniform field figured strongly in the dipole problem. When the shape of the field changed, so did the resulting motion. This suggests that we could solve some problems just knowing the symmetry, or at least that symmetry might help us do simple predictions to help get a problem started. We need to be able to predict the field lines of a geometry to draw a picture to start solving a problem.

We have run into two geometries so far that have been helpful

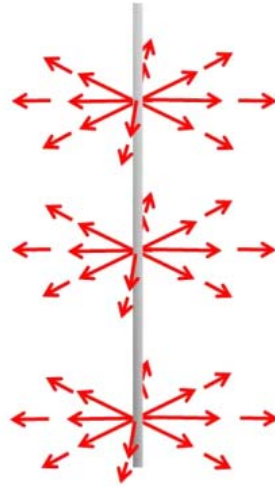

Infinite Line of Charge

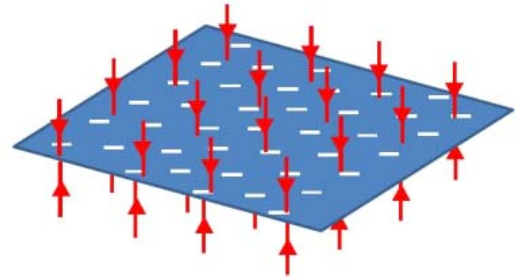

Semi-infinite Sheet of Charge

The infinite line of charge and the semi-infinite sheet of charge. We have found for the sheet that the field is constant everywhere. This is strongly symmetric. We could envision translating the sheet within the plane right or left. The field would look the same. We could envision reflecting the sheet so the left side is now the right side. That would also not change the field. We can say that the field of the sheet would be symmetric about translation within the plane of the sheet and symmetric on reflection.

Suppose we look at the sheet side-on. Suppose that we thought the field came off the sheet at an angle as shown.

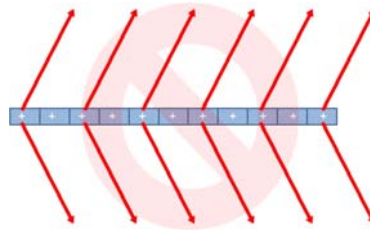

Notice that if we shift the sheet right or left, the field would still look the same, but if we reflected the sheet about the  $y$ -axis. Then we would have

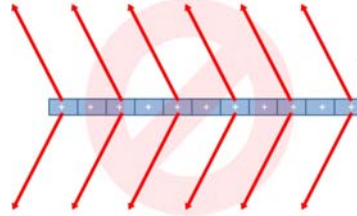

But (and here is the important part) the shape of the charge distribution did not change on reflection. The sheet really looks just the same. It does not make sense that we should change the shape of the field if the shape of the charge distribution did not change. So we can tell that this can't be the right field shape.

Question 223.25.5

We can do this with any symmetric distribution of charge. Think of the infinite line of charge. If we move it left or right the field definitely changes. So it is not symmetric about translation along, say, the  $x$ -axis. But if we move the wire along its own axis, (for my coordinate system, along the  $y$ -axis) it should be symmetric because the charge distribution won't look different. We can guess from the last example that the field must come straight out perpendicular to the line of charge. It must be perpendicular, but what direction? Look at this end view. The field lines do come straight out, so this meets our criteria for being perpendicular to the line.

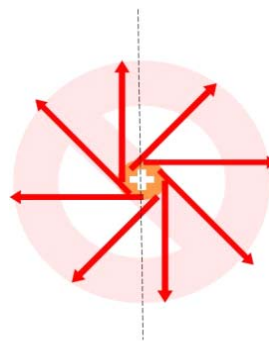

Line of Charge, End View

We could rotate the line about the axis of the line. Then the charge distribution would



look just the same. The field would also look just the same on rotation. But if we reflect the charge distribution across the axis shown, the charge distribution looks just the same, but the field would change.

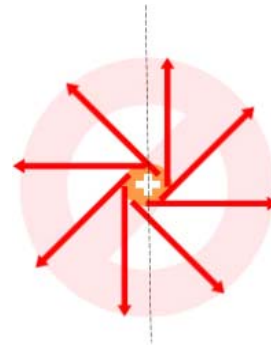

Line of Charge, Reflection

We can tell that this is not the right field. We can tell that the field should look more like this.

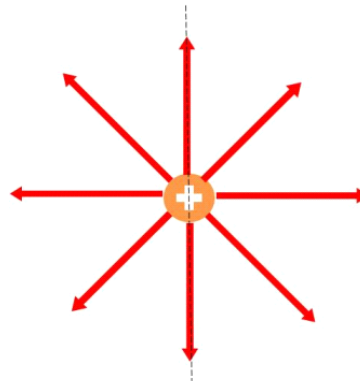

Line of Charge, End View

## Combinations of symmetric charge distributions

Question 223.25.6

We can combine sheets or lines of charge to build more complex systems. We did this to form a capacitor

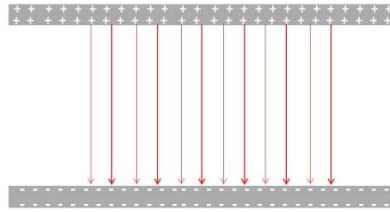

The field lines follow our symmetry guidelines. Because of the symmetry of the sheet of the field lines must be perpendicular to the sheets.

Again building from the line of charge, we can build more complex geometries

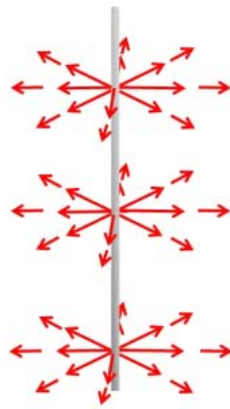

Infinite Line of Charge

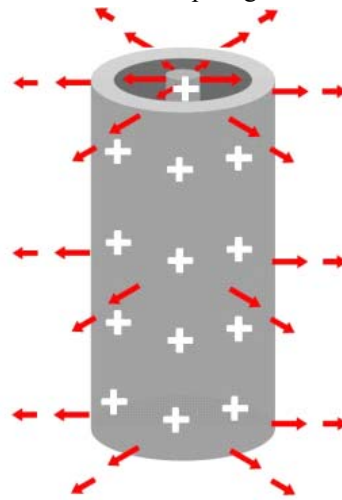

Charged Coaxial Cylinders

In the figure we have two positively charged concentric cylinders. The field is very reminiscent of a line charge field, and we can see that it must be using the same symmetry rules.

Of course the cylinders don't have to have the same charge.



Oppositely Charged Coaxial  
Cylinders

If the interior cylinder is positively charged and the exterior cylinder is negatively charged, we have a situation much like the capacitor. Each cylinder has a field outside the system, but those fields cancel out if there are equal charges on each cylinder. This situation is similar to a coaxial cable, and we will revisit it later in the course.

For the charge configurations we have drawn so far, we must keep in mind that they are infinite in at least one dimension. Finite configurations of charge in lines or sheets will have curved fields at the ends. The fields will be symmetric on reflection about their centers, but not on translation of any sort. Still, we will continue to use semi-infinite approximations in this class, and these constructs are good mental images under many circumstances.

Of course we can have a sphere. Spheres are very symmetrical, so we can guess using our symmetry ideas that the field from a charged sphere should be perpendicular to the surface of the sphere everywhere.

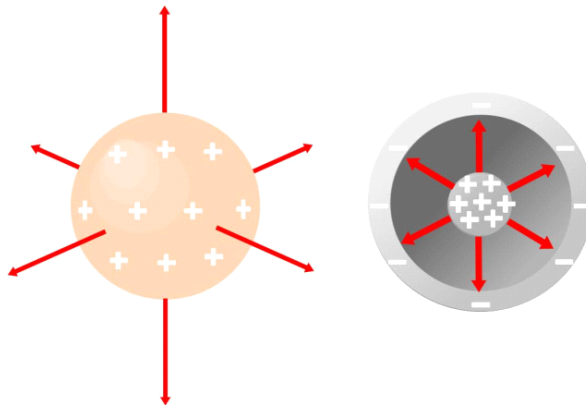

We can see that this is true for both the sphere and for concentric spheres or any

configuration of charge that is spherical.

## Basic Equations

$$\vec{\tau} = \vec{p} \times \vec{E}$$

# 7 Electric Flux

## Fundamental Concepts

- Electric flux is the amount of electric field that penetrates an area.
- An area vector is a vector normal to the area surface with a magnitude equal to the area.
- For closed surfaces, flux going in is negative and flux going out is positive by convention.

### The Idea of Flux

Van de Graaff Generator Demo

Question 223.26.1

If you took PH123 or have had a class that deals with fluids, I can use an analogy (if not, you will probably be OK, because you have probably used a garden hose). Let's recall some fluid dynamics for a moment. Remember what we called a *flow rate*? This was from the equation of continuity

$$v_1 A_1 = v_2 A_2$$

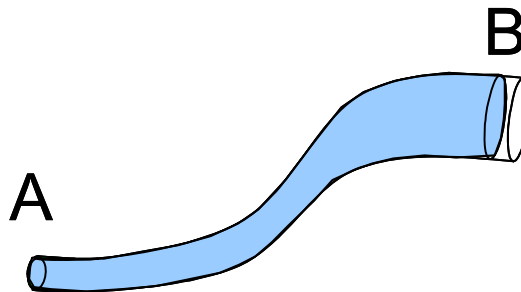

We wanted to know how much liquid was going by a particular part of the pipe in a given unit of time. We called  $vA$  a *flow rate*.

### The idea of electric flux

I want to introduce an analogous concept. But this time I want to use the electric field instead of water speed

$$\Phi = EA$$

This is just like our flow rate in some ways. It is something multiplied by an area. In fact, it is how much of something goes through an area. We could guess that it is the amount of electric field that passes through the area,  $A$ . Now the electric fields we have dealt with so far don't flow. They just stay put (we will let them change later in the course). So it is only *like* a flow rate. But it is useful to think of this as "how much of something passes by an area," and the "something" is the electric field in this case. Let's consider a picture

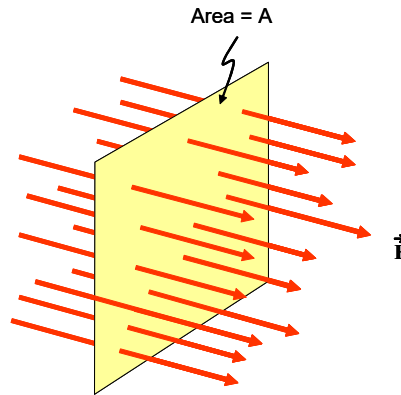

In this picture, we have a rectangular area,  $A$ , and the red arrows represent the field lines of the electric field. The arrows penetrate the area like a target. So there is a number of arrows that go through the area. They don't flow through the area, but they do penetrate it. We can picture the quantity,  $\Phi$ , as the number of field lines that pass through  $A$ . Remember that the number of field lines we draw is greater if the field strength is higher, so this quantity,  $\Phi$ , tells us something about the strength of the field over the area.

Question 223.26.2

But, what if the area,  $A$ , is not perpendicular to the field?

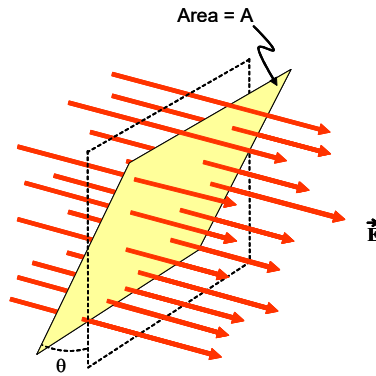

We define an angle,  $\theta$  (our favorite greek letter, but we could of course use  $\beta$  or  $\alpha$ , or  $\zeta$  or whatever) that is the angle between the field direction and the area. A more mathematical way to do this is to define a vector that is perpendicular to (normal to) the surface  $\hat{n}$ . Then we can use this vector and one of the field lines to define  $\theta$ . It will be the angle between  $\hat{n}$  and the field lines.

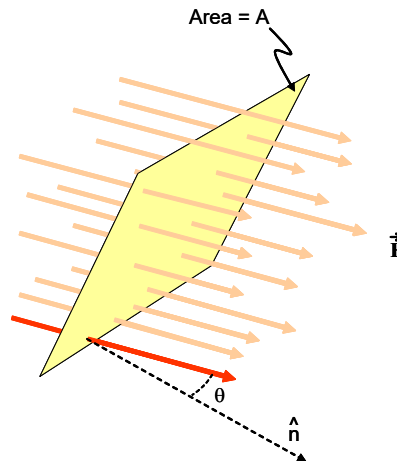

Of course either way gives the same  $\theta$ .

Now our definition of  $\Phi$  can be made to work. We want the number of field lines passing through  $A$ , but of course, now there are fewer lines passing through the area because it is tilted. We can find  $\Phi$  using  $\theta$  as

$$\Phi = EA \cos \theta \quad (7.1)$$

but let's consider what

$$A \cos \theta$$

Tip a flat object

means. We can start with our original area.

Side View



Front view

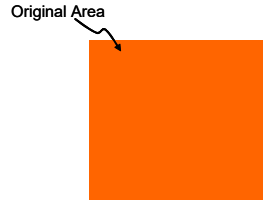

If we tip the area, it looks smaller

Side View

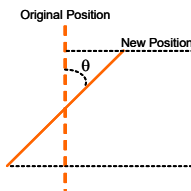

Front view

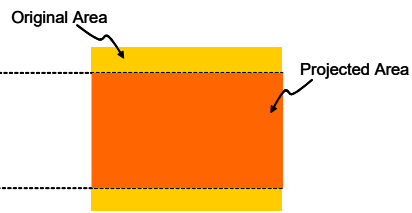

The smaller area is called the *projected area*.

We can see that by tipping our area, we get fewer field lines that penetrate that area.

Really the number of field lines is just proportional to  $E$ , so we won't ever really count field lines. But this is a good mental picture for what flux means. Really we will calculate

$$\Phi = EA \cos \theta$$

The  $\cos \theta$  with two magnitudes (field strength and area) multiplying it should remind you of something. It looks like the result of a vector dot product. If  $E$  and  $A$  were both vectors, then we could write the flux as

$$\Phi = \vec{E} \cdot \vec{A} \tag{7.2}$$

Demonstrate with a document with writing on one side

Well, we can define a vector that has  $A$  as its magnitude and is in the right direction to make

$$\vec{E} \cdot \vec{A} = EA \cos \theta$$

We define the *area vector*

$$\vec{A} = \hat{n}A \tag{7.3}$$

Notice that for an open surface (one that does not form a closed surface with a empty space inside) we have to choose which side  $\hat{n}$  will point from. We can choose either side. But once we have made the choice, we have to stick with it for the entire problem



we are solving.

Trifold paper

### Flux and Curved Areas

Suppose the area we have is not flat? Then what? Well let's recall that if we take a sphere the surface will be curved. But if we take a bigger sphere, and look at the same amount of area on that sphere, it looks less curved.

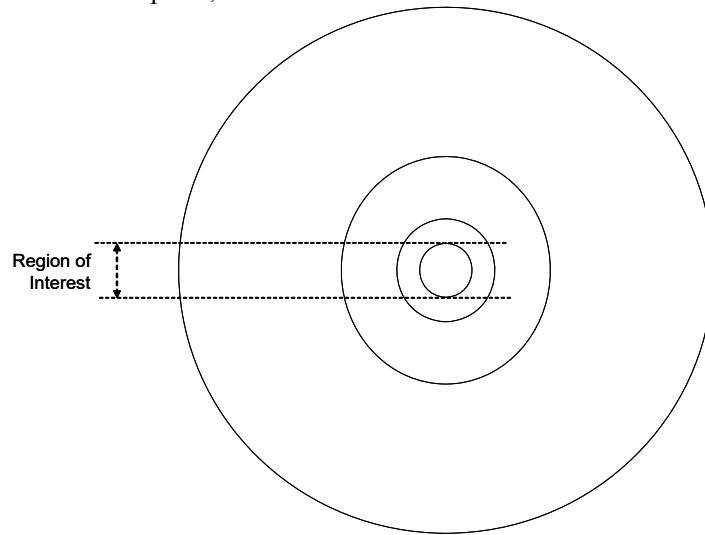

This becomes more apparent if we remove the rest of the circle or sphere to take away the visual cues our eyes and minds use to say something is curved



Suppose we take a curved surface but we just look at a very small part of that surface. This would be very like magnifying our circle. We would see an increasingly flat surface piece compared to our increased scale of our image.

This gives us the idea that for an element of area,  $\Delta A$  we could find an element of flux  $\Delta \Phi$  for this small part of the whole curved surface. Essentially  $\Delta A$  is flat (or we would

just take a smaller  $\Delta A$ ).

$$\Delta\Phi = \vec{E} \cdot \Delta\vec{A} \tag{7.4}$$

This is just a small piece of the total flux through the curved surface, the total flux through our whole curved surface is

$$\Phi_E \approx \sum \Delta\Phi \tag{7.5}$$

Of course, to make this exact, we will take the limit as  $\Delta A \rightarrow 0$  resulting in an integral. We find the flux through a curved surface to be

$$\Phi_E = \lim_{\Delta A \rightarrow 0} \sum_i \vec{E} \cdot \Delta\vec{A}_i = \int_{surface} \vec{E} \cdot d\vec{A} \tag{7.6}$$

Notice that this is a *surface integral*. It may be that you have not done surface integrals for some time, but we will practice in the upcoming lectures.

### Closed surfaces

Suppose we build a box with our areas.

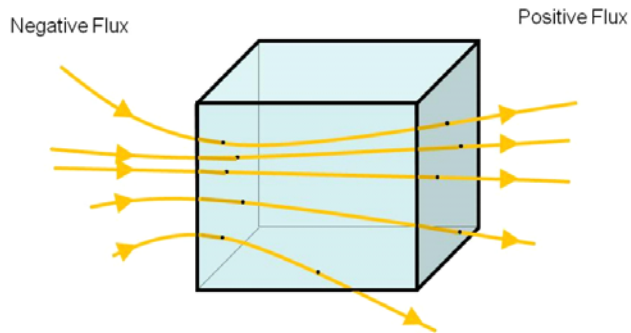

Then we would have some lines going in and some going out. By convention we will call the flux formed by the ones going in negative and the flux formed by the ones going out positive. From these questions we see that if there is no charge inside of the box, the net flux must be zero. We could take any size or shape of closed surface and this would be true! But if we do have charge inside of the box we expect there to be a net flux. If it is a negative net charge, it will be a negative flux and if it is a positive net charge it will be a positive net flux. Next lecture we will formalize this as a new law of physics, but for now we need to remember from M215 or M113 how to write an integration over a closed surface. We use a special integral sign with a circle

$$\Phi_E = \oint \vec{E} \cdot d\vec{A} \tag{7.7}$$

Question 223.26.3  
Required

Question 223.26.4  
Required

Question 223.26.5

## Flux example: a sphere

For each type of surface we choose, we need an area element,  $dA$ , with which we perform the integration. This is a lot like finding  $dq$  in our electric field integral. In our integration of the electric field due to a distribution of charges, we have used elements of area for flat surfaces. Remember our integration of over a disk of charge. We had a small area element

$$dA = r dr d\phi$$

and to find  $dq$  we just multiplied by the surface charge density.

$$\vec{E} \cdot d\vec{A}$$

is very similar. So we are familiar ground when we find elements of area.

But so far we have not found an area element for a sphere. Let's tackle that now. We can start by finding the coordinates of a point,  $P$ , on the surface of the sphere.

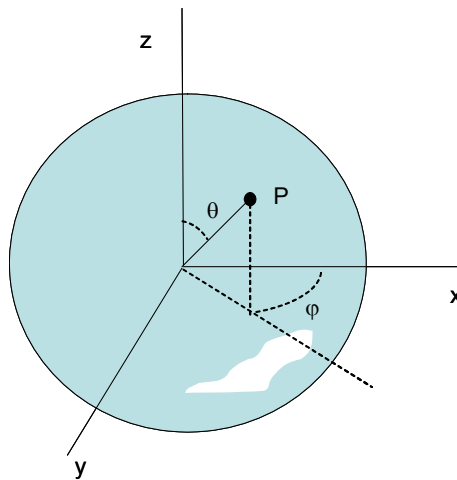

We define the coordinates in terms of two angles,  $\theta$  and  $\phi$ . Let's look at them one at a time. First  $\theta$

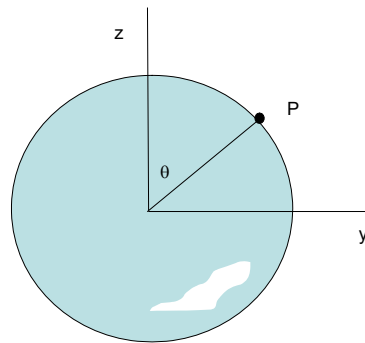

Side View

and now  $\phi$

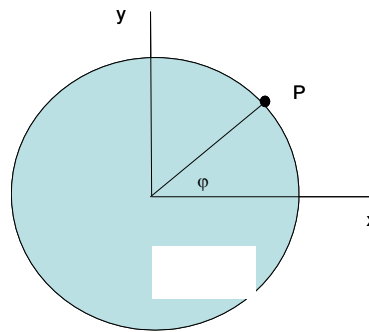

Top View

Let's build an area by defining a sort of box shape on the surface by allowing a change in  $\theta$  and  $\phi$  ( $\Delta\theta$  and  $\Delta\phi$ ). First  $\Delta\theta$ ,

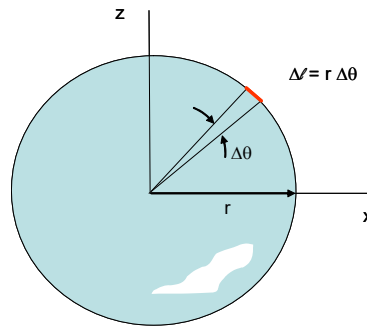

Side View

The angle  $\theta$  just defines a circle that passes through the “north pole” and “south pole” of our sphere. By changing  $\theta$  we get a small bit of arc length. We remember that the length of an arc is

$$s_\theta = r\theta \tag{7.8}$$

where  $\theta$  is in radians. So we expect that

$$\Delta s_\theta = r\Delta\theta \tag{7.9}$$

We can check this by integrating

$$\int_0^{2\pi} r d\theta = r \int_0^{2\pi} d\theta = 2\pi r \tag{7.10}$$

Just as we expect, the integral of arc length around the whole circle is the circumference of the circle. Then  $\Delta s_\theta$  is one side of our small box-like area, the box height.

Now let's look at  $\phi$

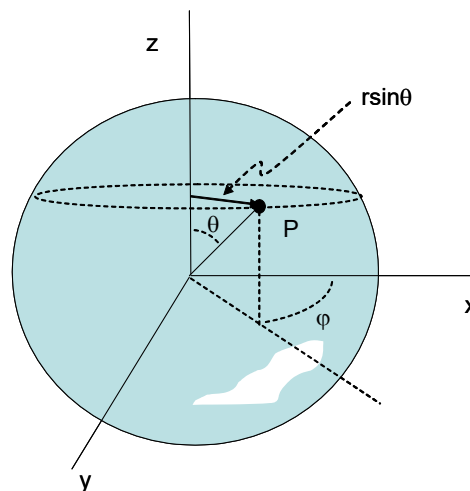

$\phi$  also forms a circle on the sphere, but its size depends on  $\theta$ . Near the north pole, the radius of the  $\phi$ -circle is very small. At  $\theta = 0$ , the  $\phi$ -circle is in the  $xy$  plane and has radius  $r$ . We can write the radius of the  $\phi$ -circle as a projection over  $90^\circ - \theta$  which gives us a radius of  $r \sin \theta$ . Then we use the arc length formula again to find

$$s_\phi = (r \sin \theta) \phi \tag{7.11}$$

a change in arch length will be

$$\Delta s_\phi = (r \sin \theta) \Delta \phi \tag{7.12}$$

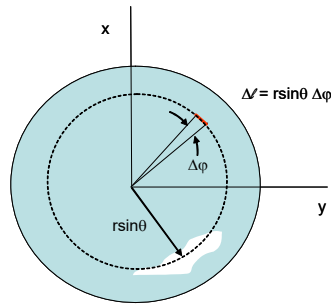

Top View

This is the other side of our box, the box width.

Now let's combine them. We multiply  $\Delta s_\theta \times \Delta s_\phi$  to obtain a roughly rectangular area.

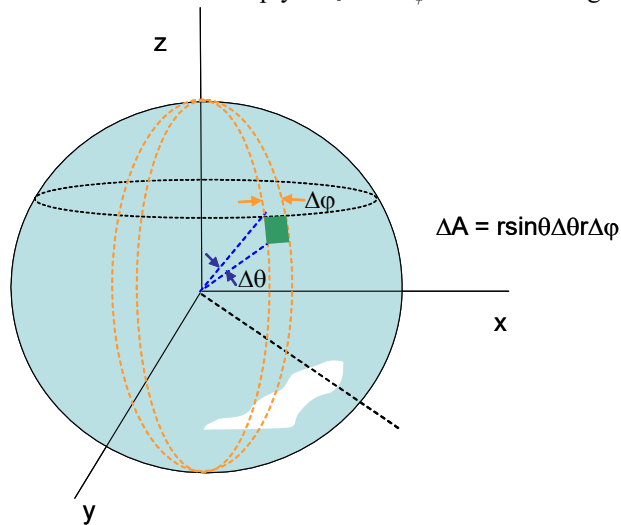

$$\Delta A \approx \Delta s_\theta \times \Delta s_\phi = r \Delta \theta r \sin \theta \Delta \phi \tag{7.13}$$

which is the area of our small box. We have found an element of area on the surface of

the sphere! all we have to do is to let the  $\Delta$ 's become  $d$ 's.

$$dA \approx ds_\theta \times ds_\phi = r d\theta r \sin \theta d\phi \tag{7.14}$$

Let's check our element of area by integration. After changing  $\Delta$  to  $d$  and rearranging

$$dA = r^2 \sin \theta d\theta d\phi \tag{7.15}$$

then

$$A = \int \int r^2 \sin \theta d\theta d\phi \tag{7.16}$$

we have to be careful not to over count area. Let's view this as first integrating around the circle of radius  $r \sin \theta$  over the variable  $\phi$ , then an integration of all these circles as  $\theta$  changes from 0 to  $\pi$

$$\begin{aligned} A &= \int_0^\pi \int_0^{2\pi} r^2 \sin \theta d\phi d\theta & (7.17) \\ &= r^2 \int_0^\pi \sin \theta d\theta \int_0^{2\pi} d\phi \\ &= 2\pi r^2 \int_0^\pi \sin \theta d\theta \\ &= 4\pi r^2 \end{aligned}$$

as we expect.

We are now ready to do a simple problem.

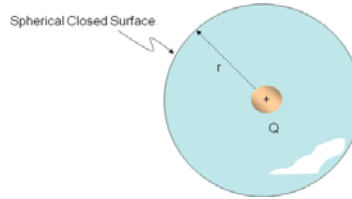

Let's calculate the flux through a spherical surface if there is a point charge at the center of the sphere. The field of the point charge is

$$\vec{E} = \frac{1}{4\pi\epsilon_o} \frac{Q_E}{r^2} \hat{r}$$

then the flux through the surface is

$$\begin{aligned} \Phi_E &= \oint \vec{E} \cdot d\vec{A} \\ &= \oint \frac{1}{4\pi\epsilon_o} \frac{Q_E}{r^2} \hat{r} \cdot d\vec{A} \end{aligned}$$

but  $\hat{r}$  is always in the same direction as  $d\vec{A}$  for this case, so

$$\hat{r} \cdot d\vec{A} = (1)dA \cos(0) = dA$$

which gives us just

$$\begin{aligned}
 \Phi_E &= \frac{Q_E}{4\pi\epsilon_o} \oint \frac{1}{r^2} dA \\
 &= \frac{Q_E}{4\pi\epsilon_o} \oint \frac{1}{r^2} r^2 \sin\theta d\theta d\phi \\
 &= \frac{Q_E}{4\pi\epsilon_o} \int_0^\pi \left( \int_0^{2\pi} d\phi \right) \sin\theta d\theta \\
 &= \frac{Q_E}{4\pi\epsilon_o} 4\pi \\
 &= \frac{Q_E}{\epsilon_o}
 \end{aligned}$$

Some comments are in order. Our surfaces that we are using to calculate  $\Phi_{\text{ux}}$  might be a real object. You might calculate the electric  $\Phi_{\text{ux}}$  leaving a microwave oven, or a computer case to make sure you are in keeping emissions within FCC rules. But more likely the surface is purely imaginary—*just something we make up*.

Symmetry is going to be very important in doing problems with  $\Phi_{\text{ux}}$ . So we will often make up very symmetrical surfaces to help us with our problems. In today's problem, the fact that  $\hat{r}$  and  $d\mathbf{A}$  were in the same direction made the integral *much* easier.

Until next lecture, it may not seem beneficial to invent some strange symmetrical surface and then to calculate the  $\Phi_{\text{ux}}$  through that surface. But it is, and it will have the effect of turning a long, difficult integral into a simple one, when we can pull it off.

### Flux example: a long straight wire

Let's take another example. A long straight wire.

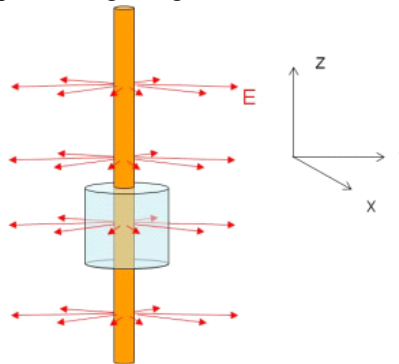



We remember that the field from a long straight wire is approximately

$$E = \frac{1}{4\pi\epsilon_0} \frac{2|\lambda|}{r}$$

The symmetry of the field suggests an imaginary surface for measuring the flux. A cylinder matches the geometry well. Let's find the flux through an imaginary cylinder that is  $L$  tall and has a radius  $r$  and is concentric with the line of charge. Note that we are totally making up the cylindrical surface. There is not really any surface there at all.

The flux will be

$$\Phi_E = \oint \tilde{\mathbf{E}} \cdot d\tilde{\mathbf{A}}$$

We can view this as three separate integrals

$$\Phi_E = \oint_{top} \tilde{\mathbf{E}} \cdot d\tilde{\mathbf{A}} + \oint_{side} \tilde{\mathbf{E}} \cdot d\tilde{\mathbf{A}} + \oint_{bottom} \tilde{\mathbf{E}} \cdot d\tilde{\mathbf{A}}$$

since our cylinder has end caps (the top and bottom) and a curved side.

Let's consider the end caps first. For both the top and the bottom ends,  $\tilde{\mathbf{E}} \cdot d\tilde{\mathbf{A}} = 0$  everywhere. No field goes through the ends. So there is no flux through the ends of the cylinder.

There is flux through the side of the cylinder. Note that the field is perpendicular to the side surface everywhere. So  $\tilde{\mathbf{E}} \cdot d\tilde{\mathbf{A}} = EdA$ . We can write our flux as

$$\begin{aligned} \Phi_E &= \oint_{side} EdA \\ &= \oint \frac{1}{4\pi\epsilon_0} \frac{2|\lambda|}{r} dA \end{aligned}$$

Integrated over the side surface. But we will need an element of surface area  $dA$  for a cylinder side. Cylindrical coordinates seem logical so let's try

$$dA = rd\theta dz$$

then

$$\begin{aligned} \Phi_E &= \oint \oint \frac{1}{4\pi\epsilon_0} \frac{2|\lambda|}{r} rd\theta dz \\ &= \frac{2|\lambda|}{4\pi\epsilon_0} \int_0^L \int_0^{2\pi} d\theta dz \\ &= \frac{|\lambda|}{2\pi\epsilon_0} (2\pi L) \\ &= \frac{|\lambda|}{\epsilon_0} L \end{aligned}$$

So far we have, indeed, made integrals that look hard but are really easy to do. But note that this would be *much* harder if the wire were not at the center of the cylinder, or if in the previous example the charge had been off to one side of the sphere.

We would still like to remove such difficulties if we can. And often we can by choosing our imaginary surface so that the symmetry is there. But sometimes that is harder. or worse yet, we don't know exactly where the charges are in a complicated configuration of charge. We will take this on next lecture when we study a technique for finding the electric field invented by Gauss.

## Basic Equations

The electric flux is defined as

$$\Phi_E = \vec{\mathbf{E}} \cdot \vec{\mathbf{A}} = EA \cos \theta$$

where the area vector is given by

$$\vec{\mathbf{A}} = \hat{\mathbf{n}}A$$

and for a curved area, we integrate

$$\Phi_E = \oint \vec{\mathbf{E}} \cdot d\vec{\mathbf{A}}$$

# 8 Gauss' Law and its Applications

## Fundamental Concepts

- Gauss' Law tells us that the flux through a closed surface is equal to the charge inside the surface divided by  $\epsilon_o$ :

$$\Phi = \frac{Q_{in}}{\epsilon_o}$$

- Gauss' Law combined with our basic flux equation

$$\Phi_E = \oint \vec{E} \cdot d\vec{A} = \frac{Q_E}{\epsilon_o}$$

## Gauss' Law

Last lecture we did two problems. We found the flux from a point charge through a spherical surface to be

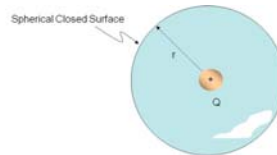

$$\Phi_{sphere,point} = \frac{QE}{\epsilon_o}$$

and the flux from a line of charge through a cylinder to be

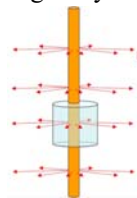

$$\Phi_{cylinder,line} = \frac{|\lambda|L}{\epsilon_o}$$

Let's rewrite the last one using

$$\lambda = \frac{Q}{L}$$

then

$$\begin{aligned} \Phi_{cylinder,line} &= \frac{|Q_E/L|L}{\epsilon_o} \\ &= \frac{|Q_E|}{\epsilon_o} \end{aligned}$$

which is just what we got for the point charge and sphere! That is amazing! Think about how much work it was to find each  $\square ux$ , and in the end we got the same result. Wouldn't it be great if the  $\square ux$  through every closed surface was this simple? Then we would not have to integrate at all!

To see if we can do this, first let's think of our answer.

$$\Phi_{sphere,point} = \frac{Q_E}{\epsilon_o}$$

Question 223.27.1

It does not depend on the radius of the spherical surface. So any spherical surface centered on the charge will do! This makes sense. No matter how big the sphere, all the field lines must leave it. Since  $\square ux$  gives the amount of field that penetrates an area, for our charge at the center of a sphere we see that all of the field penetrates the spherical surface no matter the size of the sphere. So the  $\square ux$  is the same no matter  $r$ .<sup>9</sup>

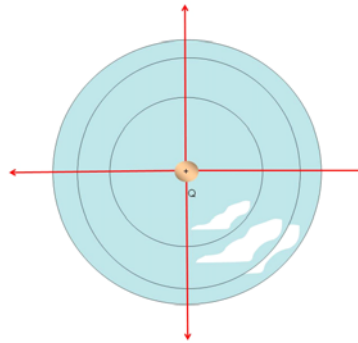

The key to making our last lecture problems easy was that the field was always perpendicular to the surface so  $\vec{E} \cdot d\vec{A} = EdA$  was easy to find.

Using geometry we can arrange to make nearly all of our  $\square ux$  problems like this. To demonstrate, let's take the case of a point charge that is off center.

<sup>9</sup> If this still seems strange, remember that the area of a sphere is  $4\pi r^2$  and that the field of a point charge is  $\frac{1}{4\pi\epsilon_o} \frac{Q}{r^2}$ . The  $\square ux$  is like the product of these two quantities. The  $r^2$  terms must cancel. So the fact that the  $\square ux$  is the same for any sphere is due to the  $r^2$  dependence of the field.

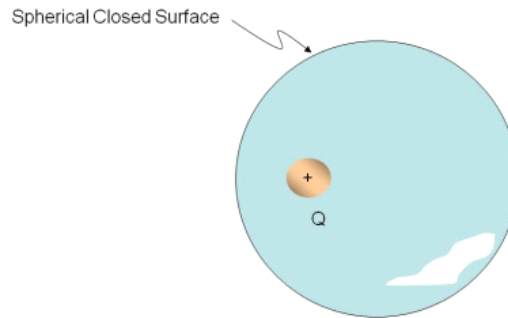

This would make for a difficult integration because  $\vec{E}$  and  $d\vec{A}$  have different directions as we go around the sphere. But let's consider, would there be less flux through the surface than there was when the charge was centered in the sphere? Every field line that is generated will still leave the surface. Flux gives us the amount of field that penetrates the surface.<sup>10</sup> Since flux is the amount of field penetrating our surface, it seems that the flux should be exactly the same as when the charge was in the center of the sphere. To prove this, let's take our surface and approximate it using area segments. But let's have the area segments be either along a radius of a sphere centered on the charge, or along the surface of a sphere centered on the charge.

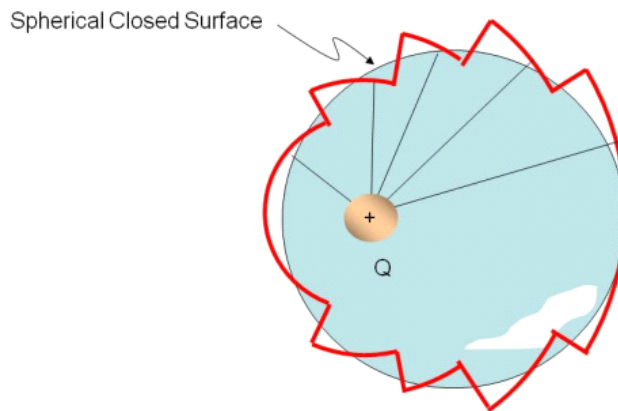

No flux goes through the radial pieces. And the rest of the pieces are all parts of spheres centered on the charge. But for the spherical segments, the field will be perpendicular to the segment no matter what sphere the segment is a part of, because we chose only spheres that were concentric with the charge. The  $r$  we have for the little spherical pieces does not matter, so on all of these surfaces  $\vec{E} \cdot d\vec{A} = E dA$ . Then the integration for these pieces will be easy.

<sup>10</sup> Think of water flow rate again. We could place the end of a garden hose in a wire mesh container. The water would flow out the hose end and through the wire mesh sides of the container. The flow rate tells us how much water passes through the container surface. The flow rate does not depend on the shape of the container. The hose end is like a charge. The hose is the source of water, the charge is the source of electric field.

Of course this surface made of little segments from other spheres is a poor approximation to the shape of the offset sphere. But we can make our small segments smaller and smaller. In the limit that they are infinitely small, our shape becomes the offset sphere. That means that once again our  $\oint \mathbf{u}_x$  is

$$\Phi = \frac{Q_E}{\epsilon_o}$$

This is fantastic! We don't have to do the integration at all. We just count up the charge inside our surface and divide by  $\epsilon_o$ .

What happens if the charge is on the outside of the surface?

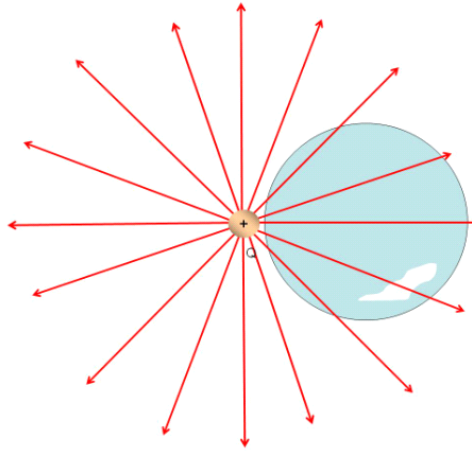

Every field line that enters goes back out. We encountered this last time. The  $\oint \mathbf{u}_x$  going in is negative, the  $\oint \mathbf{u}_x$  going out is positive, and they must be the same because every line leaves that enters. So the net  $\oint \mathbf{u}_x$  must be zero. This means we should still write our  $\oint \mathbf{u}_x$  as

$$\Phi = \frac{Q_{inside}}{\epsilon_o}$$

because outside charges won't contribute to the  $\oint \mathbf{u}_x$ . So in a way, our expression works for charges outside our closed surface.

We know that fields superimpose, that is, they add up, so we would expect that if we have two charges inside a surface,

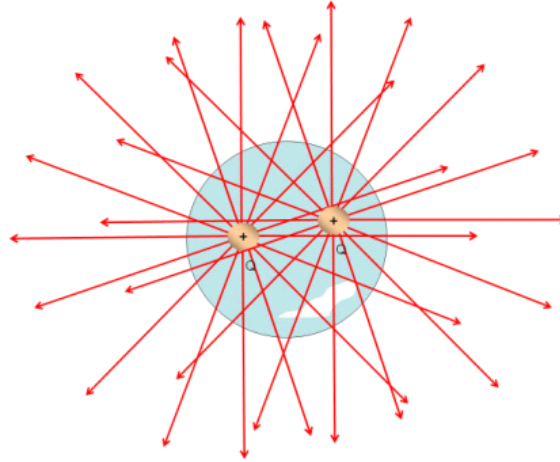

we would add up their contributions to the total flux

$$\Phi_{total} = \Phi_1 + \Phi_2$$

which means that  $Q_{inside}$  is the sum of all the charges inside. We recognize that if some charges are negative, they will cancel equal amounts of charge that are positive.

This leaves us with a fantastic time savings law

---

The electric flux  $\Phi$  through any closed surface is equal to the net charge inside the surface multiplied by  $4\pi k_e$ . The closed surface is often called a *Gaussian Surface*.

$$\Phi_E = \oint \vec{E} \cdot d\vec{A} = \frac{Q_{inside}}{\epsilon_0} \tag{8.1}$$

---

This was first expressed by Gauss, and therefore this expression is called Gauss' law.

## Examples of Gauss' Law

Question 223.27.2

But why do we get so excited about flux? The reason is that we can use the idea of flux combined with Gauss' law gives us an easy way to calculate the electric field from a distribution of charge if we can find a suitable symmetric surface! If we can find the field, we can find forces, and we can predict motion.

Let's show how to do this by working some examples.

### Charged Spherical Shell

First let's take a charged spherical shell and find the field inside. We need to be able to guess the shape of the field. We use symmetry. We can guess that the field will be radial

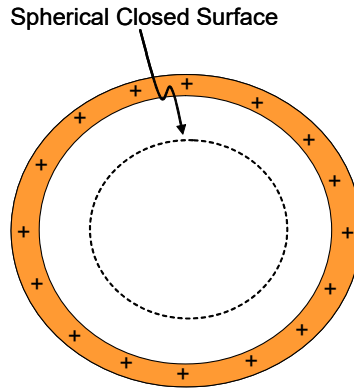

Figure 8.4.

both inside and outside of the shell. If it were not so, then our symmetry tests would fail.

The shell has a total charge of  $+Q$ . If we place a spherical surface inside the shell, then we can use Gauss's law.

$$\Phi = \frac{Q_{inside}}{\epsilon_0}$$

We can tell from the symmetry of the situation that  $\vec{E}$  is everywhere colinear with (but in the opposite direction as)  $d\vec{A}$  so

$$\Phi = \oint \vec{E} \cdot d\vec{A} = -\oint E dA$$

because the field is everywhere perpendicular to the surface. We can even make a guess that the field must be constant on this surface, because all along the spherical Gaussian surface there is extreme symmetry. No change in reflection, or rotation etc. will change the shape of the charge, so around the spherical surface the field must have the same value. Then

$$\Phi = -E \oint dA = -EA$$

Equating our flux equations gives

$$-EA = \frac{Q_{inside}}{\epsilon_0}$$

or

$$E = -\frac{Q_{inside}}{A\epsilon_0}$$

but what is  $Q_{inside}$ ? It is zero! so

$$E = -\frac{0}{A\epsilon_0} = 0$$



There is no net field inside!

This may seem surprising, but think of placing a test charge,  $q_o$ , inside the sphere. The next figure shows the forces acting on such a test charge. The force is stronger between the charge and the near surface, but there is more of the surface tugging the other way.

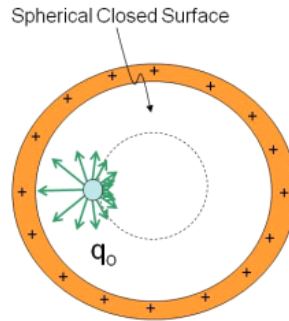

The forces just balance. Since

$$F = qE$$

Question 223.27.3

if the net force is zero, then the field must be zero too.

Is there a field outside of the spherical shell? It is still true that

$$\Phi = \oint \vec{E} \cdot d\vec{A} = \oint E dA$$

but this time we have a positive sign on the last integral because  $\vec{E}$  and  $d\vec{A}$  are in the same direction. Then

$$EA = + \frac{Q_{inside}}{\epsilon_o}$$

We now choose our surface around the entire shell. All of our analysis is the same as in

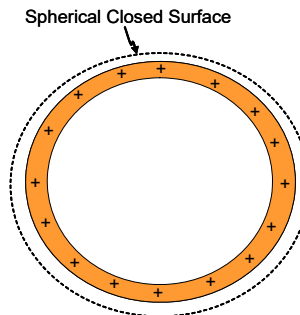

Figure 8.5.

our last problem, except now  $Q_{inside}$  is not zero

$$E = \frac{Q_{inside}}{A\epsilon_o}$$

The area is the area of our imaginary sphere

$$E = \frac{Q_{inside}}{(4\pi r^2)\epsilon_o}$$

and since  $Q_{inside} = +Q$ , then

$$E = \frac{+Q}{4\pi\epsilon_o r^2}$$

and we have found the field.

Note that this field looks very like a point charge at the center of the spherical shell (at the center of charge), but by now that is not much of a surprise!

### Strategy for Gauss' law problems

Let's review what we have done before we go on to our last example. For each Gauss' law problem, we

1. draw the charge distribution

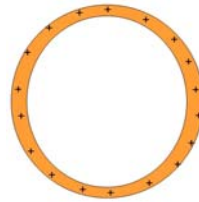

2. Draw the field lines using symmetry

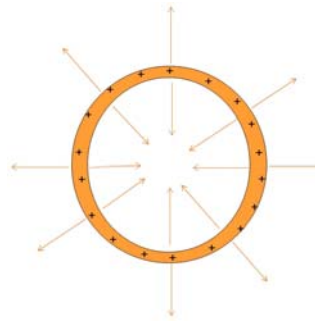

3. Choose (make up, invent) a closed surface that makes  $\vec{E} \cdot d\vec{A}$  either just  $E dA$  or 0.

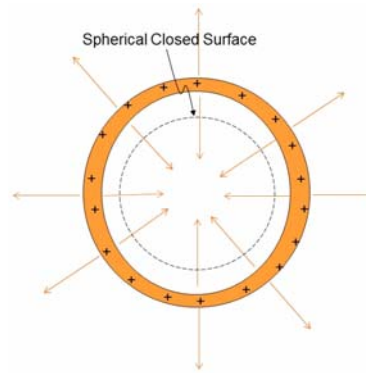

4. Find  $Q_{in}$ .

5. Solve  $\oint E dA = \frac{Q_{inside}}{\epsilon_0}$  for the non, zero parts

The integral should be trivial now due to our use of symmetry.

**An infinite sheet of charge.**

Spherical cases were easy. Let's try a harder one. Let's try our infinite sheet of charge. It is a little hard to draw. So we will draw it looking at it from the side from within the sheet of charge (somewhere in it's middle, if an infinite sheet can have a middle).

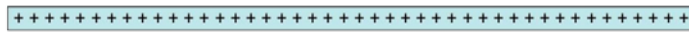

This completes step 1).

For step 2), let's think about what the electric field will look like.

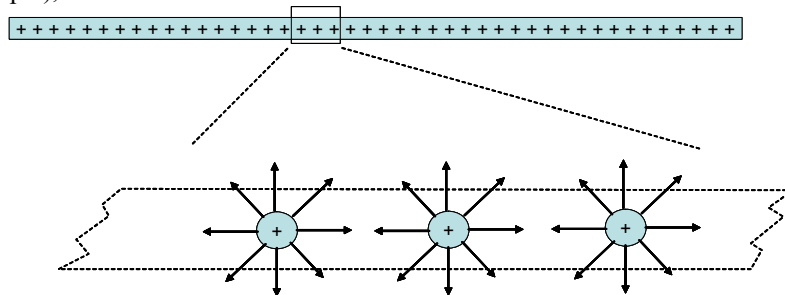

In the figure above I have blown up the view on three charge carriers and drawn some field lines. Notice that in the  $x$ -direction the fields will cancel.

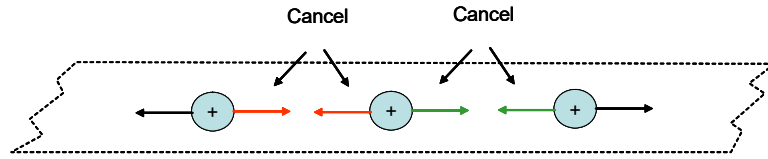

The  $y$ -components add

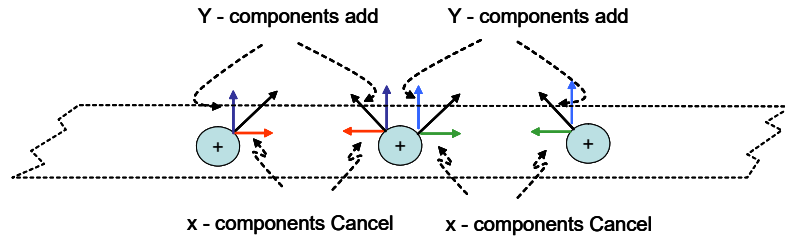

So we have only a field in the  $y$  direction

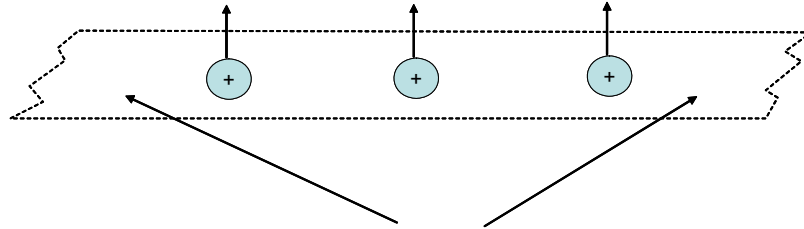

Remember that this only works if we have the rest of the sheet to cancel the components on the end charges shown

Now if we had edges of our sheet of charge, not all the  $x$ -components would cancel and the problem would be harder, but we won't do that problem now. Also note that there is a field in the  $-y$ -direction, I only drew some of the field lines in the figures.

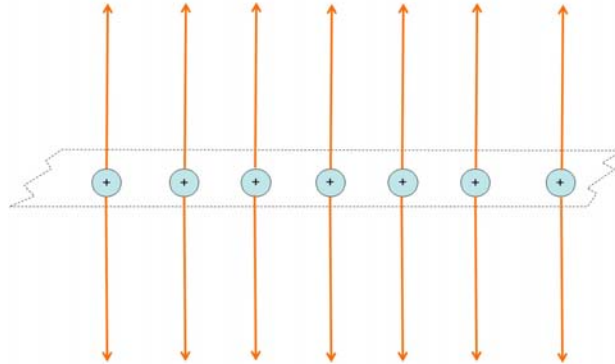

This is step 2).

Now we need to choose an imaginary surface over which to integrate  $\oint \vec{E} \cdot d\vec{A}$ . We want  $\vec{E} \cdot d\vec{A} = E dA$  or  $\vec{E} \cdot d\vec{A} = 0$  over all parts of the surface. I suggest a cylinder.

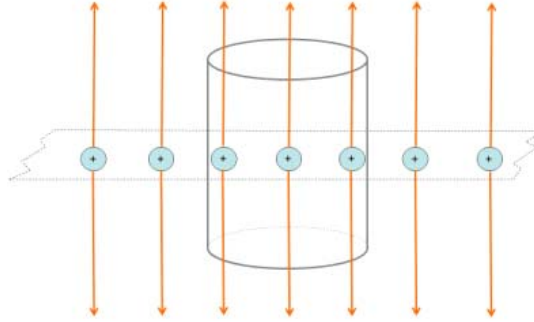

Note that along the top of the cylinder,  $E \parallel A$  so  $\vec{E} \cdot d\vec{A} = EdA \cos \theta = EdA$ . Along the side of the cylinder  $E \perp A$  so  $\vec{E} \cdot d\vec{A} = EdA \cos \theta = 0$ . We have a surface that works! This completes step 3).

Now we need to solve the integral. The flux is just

$$\begin{aligned} \Phi &= \oint \vec{E} \cdot d\vec{A} \\ \Phi &= \oint_{side} \vec{E} \cdot d\vec{A} + \oint_{ends} \vec{E} \cdot d\vec{A} \\ &= 0 + \oint_{ends} EdA = 2EA \end{aligned}$$

where the factor of 2 comes because we have two caps and field in the  $+y$  and  $-y$  directions and where  $A$  is the area of one end cap. If we know that the sheet of charge has a surface charge density of  $\eta$ , then we can write the charge enclosed by the cylinder as

$$Q_{inside} = \eta A$$

so

$$\Phi_E = \frac{\eta A}{\epsilon_0}$$

by Gauss' law. Equating the two expressions for the flux gives

$$2EA = \frac{\eta A}{\epsilon_0}$$

or

$$E = \frac{\eta}{2\epsilon_0} \tag{8.2}$$

which is what we found before for an infinite sheet of charge, but this way was *much* easier. If we can find a suitable surface, Gauss' law is very powerful!

### Gauss's law strategy

In each of our problems today, we found the electric field without a nasty integration. Usually we want the electric field at a specific point. To make Gauss' law work we need

to do the following for each problem:

1. Draw the charge distribution
2. Draw the field using symmetry
3. Invent a Gaussian surface that takes advantage of the field symmetry and that includes our point where we want the field. We will want  $\vec{E} \cdot d\vec{A} = EdA$  or  $\vec{E} \cdot d\vec{A} = 0$  for each part of the surface we invent.

4. Find the flux by finding the enclosed charge,  $Q_{in}$

5. use  $\oint \vec{E} \cdot d\vec{A} = \frac{Q_{in}}{\epsilon_0}$  integrating over our carefully invented surface to find the field. If our surface that we imagined was good, then  $\oint \vec{E} \cdot d\vec{A}$  will be very easy.

Question 223.27.4

## Derivation of Gauss' Law

A formal derivation of Gauss' Law is instructive, and it gives us the opportunity to introduce the idea of solid angle.

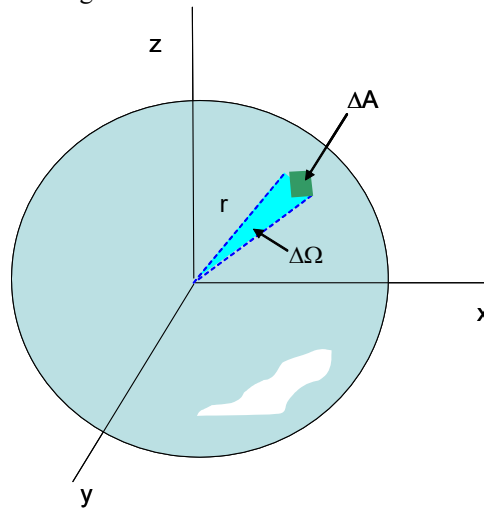

$$\Delta\Omega = \frac{\Delta A}{r^2} \quad (8.3)$$

This is like a two dimensional angle. And just like an angle, it really does not have dimensions. Note that  $\Delta A$  is a length squared, but so is  $r^2$ . The (dimensionless) unit for solid angle is the *steradian*. We can see that for a sphere we would have a total solid

angle of

$$\Omega_{sphere} = \frac{4\pi r^2}{r^2} = 4\pi \text{ sr} \tag{8.4}$$

Now let's see why this is useful. Consider a point charge in an arbitrary closed surface.

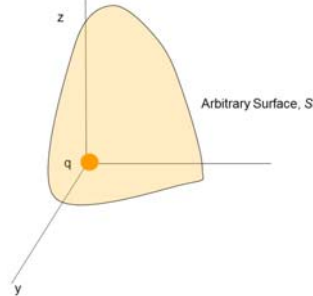

If we look at a particular element of surface  $\Delta A$  we can find the flux through that surface element. We can use our idea of solid angle to do this

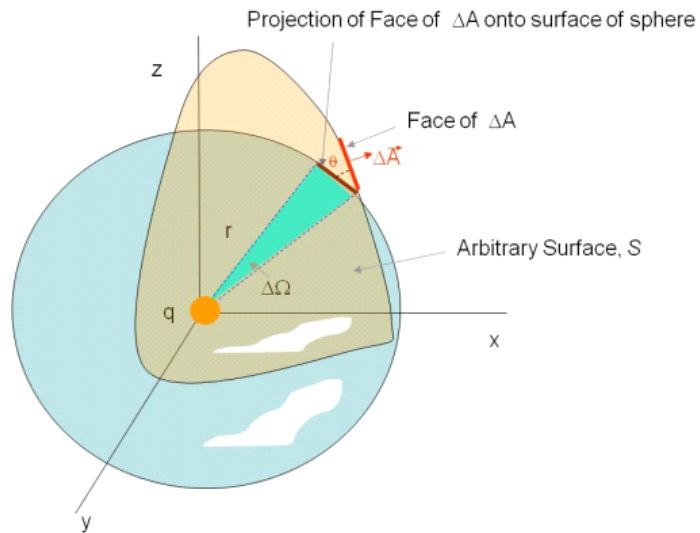

$$\Delta\Phi_E = \vec{E} \cdot \Delta\vec{A}$$

Since the field lines are symmetric about  $q$  and the surface is arbitrary, the element  $\Delta\vec{A}$  will be at some angle  $\theta$  from the field direction so

$$\vec{E} \cdot \Delta\vec{A} = E\Delta A \cos\theta$$

this is no surprise. But now notice that the projection of  $\Delta A$  puts it onto a spherical

surface of just about the same distance from  $q$ . The projected area is

$$\Delta A_P = \Delta A \cos \theta$$

At this point we should remember that we know the field due to a point charge

$$E = \frac{1}{4\pi\epsilon_o} \frac{q}{r^2}$$

so our flux through the area element is

$$\begin{aligned} \Delta\Phi_E &= \frac{1}{4\pi\epsilon_o} \frac{q}{r^2} \Delta A \cos \theta \\ &= \frac{q}{4\pi\epsilon_o} \frac{\Delta A \cos \theta}{r^2} \end{aligned}$$

but

$$\frac{\Delta A \cos \theta}{r^2} = \Delta\Omega$$

is the solid angle subtended by the projected area. Then

$$\Delta\Phi_E = \frac{q}{4\pi\epsilon_o} \Delta\Omega$$

The total flux through the oddly shaped closed surface is then

$$\Phi_E = \frac{q}{4\pi\epsilon_o} \oint d\Omega$$

where we integrate over the entire arbitrary surface,  $S$ .

$$\Phi_E = \frac{q}{4\pi\epsilon_o} \oint_S d\Omega$$

but by definition

$$\oint_S d\Omega = 4\pi \text{ sr}$$

so

$$\begin{aligned} \Phi_E &= \frac{q}{4\pi\epsilon_o} \oint_S d\Omega \\ &= \frac{q}{4\pi\epsilon_o} 4\pi \text{ sr} \\ &= \frac{q}{\epsilon_o} \end{aligned}$$

which is just Gauss' law.

So far we have used mostly charged insulators to find fields. But we know we will be interested in conductors and their fields in building electronics. We will take up the study of charged conductors and their fields next.

## Basic Equations

Gauss' law

$$\Phi = \frac{Q_{inside}}{\epsilon_o}$$



Gauss' law combined with our equation for  $\nabla \cdot \mathbf{E}$

$$\Phi = \oint \vec{\mathbf{E}} \cdot d\vec{\mathbf{A}} = \frac{Q_{inside}}{\epsilon_0}$$



# 9 Conductors in Equilibrium, Electric Potentials

## Fundamental Concepts

- Conductors in Equilibrium
- Electric Potential Energy

### Conductors in Equilibrium

Conductors have some special properties because they have movable charge. Here they are

1. Any excess static charge (charge added to an uncharged conductor) will stay on the surface of the conductor.
2. The electric field is zero everywhere *inside* a conductor.
3. The electric field just outside a charged conductor is perpendicular to the conductor surface.
4. Charge tends to accumulate at sharp points where the radius of curvature of the surface is smallest.

It is our job to convince ourselves that these are true. Lets take these one at a time.

### In Equilibrium, excess charge is on the Surface

Question 223.28.1

Let's think about what we know about conductors. Most good conductors are metals. The reason they are good conductors is that the outer electrons in metals are in open valence bands where there are many energy states available to the electrons. These electrons are free to travel around. This means that if we place a charge near a metal object, the free charges will experience an acceleration. Of course, the charge does not

ly out of the conductor. It will have to stop when it reaches the end of the metal object. Suppose we go back to our experiment from the first lecture. We took a charged rod, and placed it near an uncharged conductor.



The free electrons moved. We ended up with a bunch of electrons all on the right hand side. They all repel each other. So at some point the force between a free electron and the charged rod, and the force between a free electrons and the rest of the free electrons will balance. At that point, there is zero net force (think of Newton’s second law). The free electrons stop moving. We have a word from PH121 or Statics for when all the forces balance. We say the charges are in *equilibrium*.

Now suppose we have a conductor just on it’s own and suppose we add charge to it. Where would the extra charge go? We have considered this before. In the picture below, I have a spherical conductor with two extra negative charges shown. The pair of charges will repel each other. Now because of the  $r^2$  in our electric force equation, the closer the extra charges are, the stronger the repulsive force. The result is that they will try to go as far from each other as possible. So the extra charge on a spherical conductor will all end up on the surface.

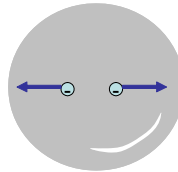

### The Electric Field is Zero *Inside* a Conductor

Question 223.28.2

We can use Gauss’ law to find the field in a conductor. We know that the extra charge will all be on the surface if there is no electric current.

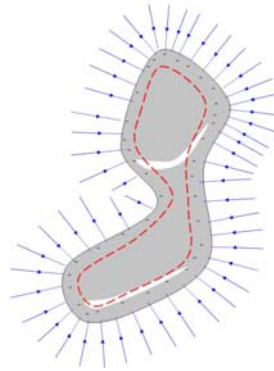

We can then draw a Gaussian surface, to match the symmetry of the conductor. What is the charge inside? It is zero, since the remaining charge is all bound up in atoms and balances out. Since there is no net charge, there is no net  $\oint \mathbf{E} \cdot d\mathbf{A}$ . If there is no  $\oint \mathbf{E} \cdot d\mathbf{A}$ , there is no net field inside a conductor that is in static equilibrium.

Note that if we connected this conductor to both ends of a battery, we would have a field in the conductor, so we must remember that static equilibrium is a special case.

If we don't connect the conductor to the ground or a battery, we can say: *The net electric field is zero everywhere inside the conducting material.*

Consider if this were not true! If there were an electric field inside the conductor, the free charge there would accelerate and there would be a flow of charge. If there were a movement of charge, the conductor would not be in equilibrium. Suppose we place a brick of conductor in a field. We expect that the charges will be accelerated. Negative charges will move opposite the field direction. We end up with the situation shown in the next figure.

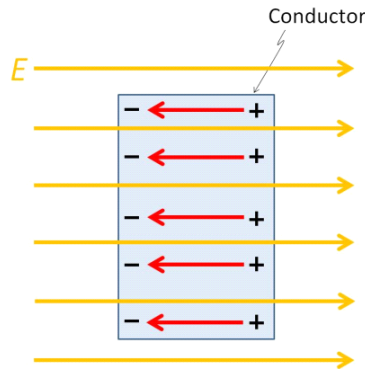

Since the negative charges moved, the other side has a net positive charge. This separation of the charges creates a new field in the opposite direction of the original

field. In equilibrium, just enough charge is moved to create a field that cancels the original field.

### Return to charge being on the surface

Question 223.28.3

Suppose we have a conductor in equilibrium. We can now ask, what does it mean that the charge is “on the surface?” Is there a small distance within the metal where we would find extra charge? or is it all right at the edge of the metal?

Let’s look at this again now that we know Gauss’ law. Let’s envision a conducting object with a matching Gaussian surface.

Closed Gaussian Surface

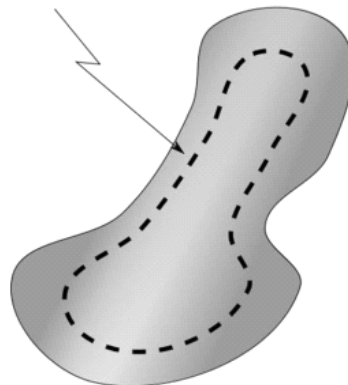

We know the field inside the conductor is zero. So no field lines can leave or enter the Gaussian surface. So no charge can be inside or we would have a net  $\oint \mathbf{E} \cdot d\mathbf{A}$ , and, therefore, a field. We can move the Gaussian surface from the center of the conductor and grow it until it is just barely smaller than the surface of the conductor, and there still must be no field, so no charge inside.

### Closed Gaussian Surface

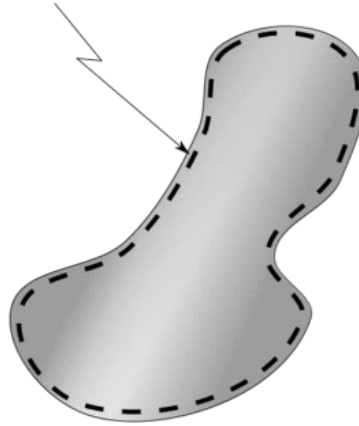

We can make this Gaussian surface as close to the actual surface as we like, and still there must be no field inside. Thus all the excess charge must be on the surface. It is not distributed at any depth in the material.

### Field lines leave normal to the surface

Question 223.28.4

In the following picture, we can see that the field lines seem to leave the surface of these charged conductors at right angles (remember that sometimes we call this *normal* to the surface).

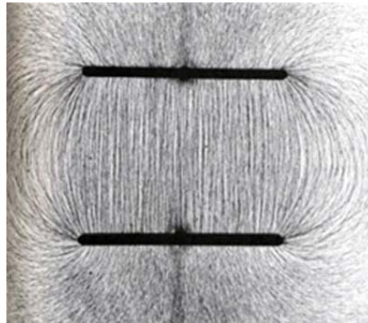

We have charges all along the surface, and neighboring charges cancel all but the normal components of the field, so the field lines go straight out. Notice that farther from the conductor the field lines may bend, but they start out leaving the surface perpendicular to the surface. Let's draw a conducting object.

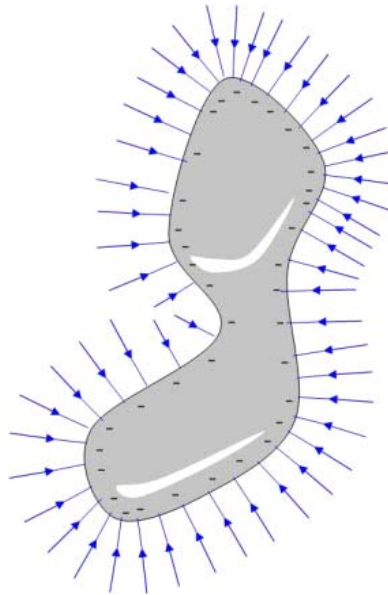

Consider what would happen if it were not true that the field lines left perpendicular to a conductor surface when the conductor was in equilibrium.

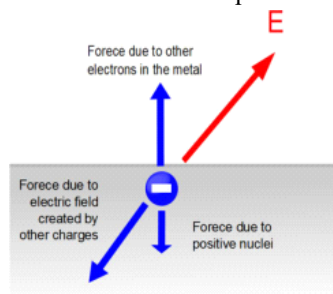

There would be a horizontal component of the field in such a case. The component of the field along the surface would cause the charge to move. In the figure there would be a net force to the left. This force would rearrange the charge until there was no force. But since  $F_x = qE_x$ , then when  $F_x$  is zero, so is  $E_x$ . Suppose we place a conductor in an external field. We would see that the charges within the conductor will rearrange themselves until the field lines will leave perpendicular to the surface of the conductors.



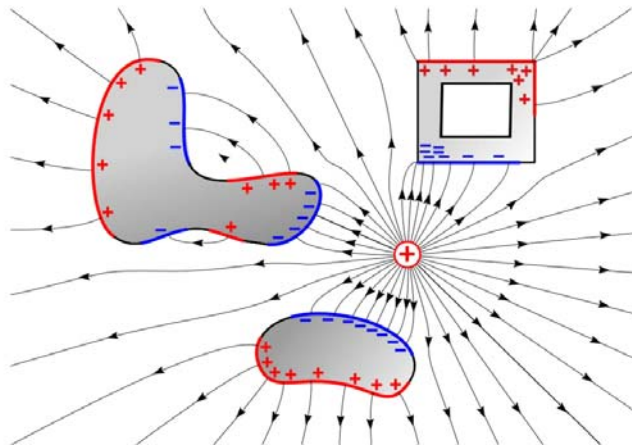

Notice the square box in the last figure. There is an opening inside the conductor, but there is no net field inside. The conductor charges rearrange themselves so that the external field is canceled out. This is part of what is known as a *Faraday cage* which allows us to cancel out an external electric field. This is used to protect electronic devices that must operate in strong electric fields. To complete the effect, we will also need to show that magnetic fields are canceled by such a conducting box.

We should also consider what happens when we place a charge in a conductive container. Does this charge get screened off?

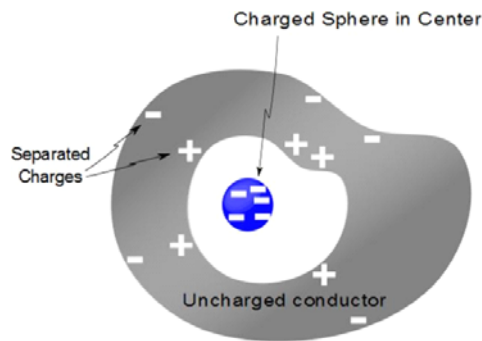

In this case, the answer is no. The charges in the conductor will move because of the charge contained inside the conducting container. The negative charge will move in the case shown, and it will move to the outside of the container surface. This leaves positive charges behind on the inner surface. We know that there will be no field inside the conductor, but think of placing a Gaussian surface around all of the container and

charge. There will be a net charge inside the Gaussian surface, so there will be a field. The inner surface charge does cancel the charge from the charged sphere. But the negative charge on the conductor surface creates a new field.

### Charge tends to accumulate at sharp points

Let's go back to our charged conductor. Notice that the field lines bunch up at the corners! Where the field lines are closer together, there must be more charge and the field strength must be higher.

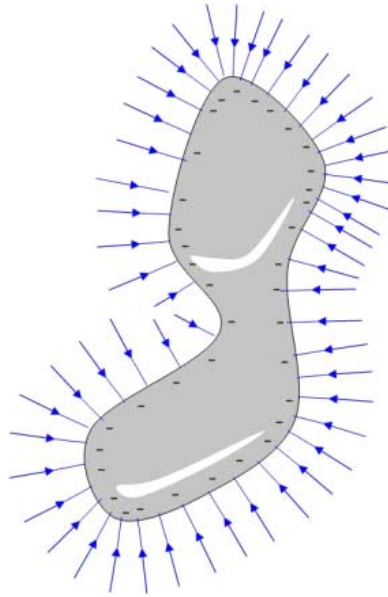

Now that we have an idea of how charge and conductors act in equilibrium, we would like to motivate charge to move. To see how this happens, let's review energy.

## Electrical Work and Energy

Question 223.28.5 We remember studying energy back in PH121 or Statics and Dynamics.

### Review of Work and Energy

Put this on the far board Remember the Work-Energy theorem?

$$W_{nc} = \Delta K + \Delta U \tag{9.1}$$

We started with gravitational potential energy, and, as we found conservative forces, we defined new potential energies to describe the work done by those forces. For example, we added spring potential energy

$$W_{nc} = \Delta K + \Delta U_g + \Delta U_s \tag{9.2}$$

I bet you can guess what we will do with our electrical or Coulomb force!

$$W_{nc} = \Delta K + \Delta U_g + \Delta U_s + \Delta U_C \tag{9.3}$$

When we do this, we mean that the work done by the Coulomb force ( $W_C$ ) is the negative of the electrical potential energy change

$$W_C = -\Delta U_C \tag{9.4}$$

and we are saying that the Coulomb force is conservative.

Remember that the equation for the force due to gravity and the equation for the Coulomb force are very alike. So we might guess that the Coulomb force is conservative like gravity—and we would be right!

### Charge in a uniform field

Question 223.28.6

Question 223.28.7

Question 223.28.8

Let's use our Coulomb force to calculate work. I would like a simple example, so let's assume we have a uniform electric field. We know that we can almost really make a uniform electric field by building a large capacitor.

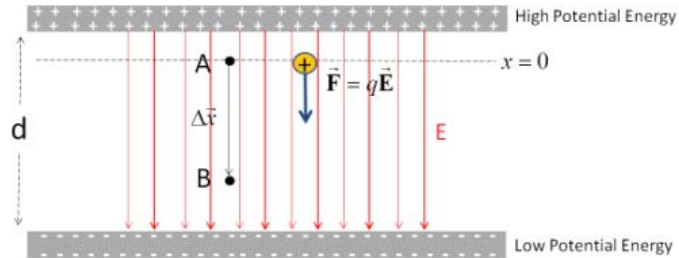

We draw some field lines (from the + charges to the - charges). The field lines will be mostly straight lines in between the plates. Of course, outside the plates, they will not be at all straight, but we will ignore this because we want to calculate work just in the uniform part of the field.

I want to place a charge,  $q$ , in this uniform field. The charge will accelerate. Work will be done. I want to find out how much work is done on the charge.

From our PH121 or Dynamics experience, we know that

$$\begin{aligned} W &= \int \vec{\mathbf{F}} \cdot d\vec{\mathbf{x}} \\ &= F\Delta x \cos \theta \end{aligned} \quad (9.5)$$

for constant forces. Because we have a constant field, we will have a constant force.

I will choose the  $x$  direction to be vertical and  $x = 0$  to be near the positive plate. Then we can write the force due to the electric field as

$$\begin{aligned} W &= F\Delta x \cos \theta \\ &= (q_m E) \Delta x \cos(0^\circ) \\ &= q_m E \Delta x \end{aligned}$$

Put this on the far board

If there are no non-conservative forces, and we ignore gravity, then we can say

$$\begin{aligned} W_{nc} &= \Delta K + \Delta U_g + \Delta U_s + \Delta U_C \\ 0 &= \Delta K + 0 + \Delta U_C \\ 0 &= \Delta K + 0 - qE\Delta x \end{aligned}$$

so

$$\Delta K = q_m E \Delta x \quad (9.6)$$

This is very interesting! This means that for this simple geometry I could ask you questions like, “after the charge travels  $\Delta x$ , how fast is it going?”

## Electric and Gravitational potential energy compared

We have found that the potential energy for the Coulomb force is given by

$$\Delta U_C = -q_m E \Delta x$$

for a *uniform* electric field (it will change for non-uniform fields). Let’s compare this to the gravitational potential energy

$$\Delta U_g = -mgh$$

Let’s set up a situation where the electric field and gravitational field are almost uniform and we have a positively charged particle with charge  $q_m$  and mass  $m$ . The height,  $h$ , we will call  $d$  to match our gravitational and electrical cases.

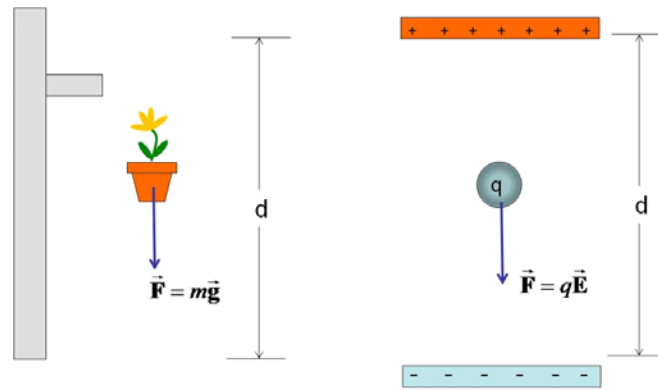

The gravitational potential difference is

$$\Delta U_g = -mgd \quad (9.7)$$

and the electrical potential difference is

$$\Delta U_C = -q_m E d \quad (9.8)$$

These equations look a lot alike. We should expect that if we push the charge  $q_m$  “up,” we will increase both potential energies. We will have to do positive work to do that ( $W = -\Delta U$ ). This is just like doing work in a gravitational field, so we are familiar with this behavior.

There is a difference, however. We have assumed that our charge  $q_m$  was positive. Suppose it is negative? There is only one kind of mass, but we have two kinds of charge. We will have to get used to negative charges “falling up” to make the analogy continue.

This analogy helps us to understand how the electric potential energy will act, and we will continue to use it. There is a difficulty, however, in that most engineering classes only study gravitation in nearly uniform gravitational fields. But if we look at large objects (like whole planets) that are separated from other objects by some distance, then we have very non-uniform gravitational fields. Unless you are an aerospace engineer, these cases are less common. So to help us understand electric potential energy, we will study gravitational potential energy of large things first, then study the energy associated with individual charges and their very non-uniform fields. We will take this on next time.

## Basic Equations



# 10 Electric potential Energy

## Fundamental Concepts

- Gravitational potential energy of point masses and binding energy
- Electrical potential energy of point charges
- Electrical potential energy of dipoles

## Point charge potential energy

As we said last lecture, we want to use gravitation as an analogy for the electric potential energy. Gravitation is more intuitive. But chances are gravitation of whole planets was not stressed in Dynamics (If you took PH121 you should be fine, and this will be a review). So let's take a few moments out of a PE101 class (introductory planetary engineering<sup>11</sup>) and study non-uniform gravitational fields.

### Gravitational analog

Question 223.29.1

Question 223.29.2

Long, long ago you studied the potential energy of objects in what we can now call the Earth's gravitational field.

The presentation of the idea of potential energy likely started with

$$U_g = mgy$$

where  $m$  is the mass of the object,  $g$  is the acceleration due to gravity, and  $y$  is how high the object is compared to a  $y = 0$  point. If you recall, we got to pick that  $y = 0$  point. It could be any height.

Notice as well that this contains the properties of the mover object,  $m$ , and the properties of the environment or gravitational field,  $g$ .

---

<sup>11</sup> Slartibartfast, *Introduction to Planetary Engineering*, Magrath Technical College, 1978

This all works fairly well so long as we take fairly small objects near the much larger Earth. But hopefully you also considered objects farther away from the Earth's surface, or larger objects like the moon. For these objects,  $mg$  is not enough to describe the potential energy. The reason is that if we are far away from the center of the Earth we will notice that the Earth's gravitational field is not uniform. It curves and diminishes with distance. So, if an object is large, it will feel the change in the gravitational field over its (the object's) large volume.

We have the tools to find the potential energy of this situation. We know that a change in potential energy is just an amount of work

$$\Delta U_g = -W_g = - \int \vec{\mathbf{F}}_g \cdot d\vec{\mathbf{r}}$$

The magnitude of the gravitational force is

$$F_g = G \frac{M_E m_m}{r_{Em}^2}$$

where  $M_E$  is the mass of the Earth,  $m_m$  is the mass of the mover object, and  $r_{Em}$  is the distance between the two. The constant,  $G$ , is the gravitational constant.

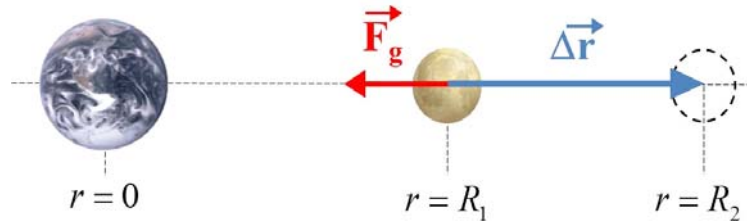

The field is radial, so  $\vec{\mathbf{F}}_g \cdot d\vec{\mathbf{r}} = -F dr$  for the configuration we have shown, and we can perform the integration. Say we move the object a distance  $\Delta r$  away were

$$\Delta r = R_2 - R_1$$

and  $\Delta r$  is large, comparable to the size of the Earth or larger. Then

$$\begin{aligned} \Delta U_g &= - \int_{R_1}^{R_2} \left( -G \frac{M_E m_m}{r^2} \right) dr \\ &= G M_E m_m \int_{R_1}^{R_2} \frac{dr}{r^2} \end{aligned}$$



where  $R$  is the distance from the center of the Earth to the center of our object.

$$\begin{aligned}
 \Delta U_g &= GM_E m_m \int_{R_1}^{R_2} \frac{dr}{r^2} \\
 &= GM_E m_m \left[ -\frac{1}{r} \right]_{R_1}^{R_2} \\
 &= GM_E m_m \left[ -\frac{1}{R_2} - \left( -\frac{1}{R_1} \right) \right] \\
 &= -GM_E m_m \left[ \frac{1}{R_2} - \frac{1}{R_1} \right] \\
 &= -G \frac{M_E m_m}{R_2} + G \frac{M_E m_m}{R_1}
 \end{aligned}$$

We recall that we need to set a zero point for the potential energy. Before, when we used the approximation  $m_m g y$  we could choose  $y = 0$  anywhere we wanted. But now we see an obvious choice for the zero point of the potential energy. If we let  $R_2 \rightarrow \infty$  and then the first term in our expression will be zero. Likewise, if we let  $R_1 \rightarrow \infty$  the second term will be zero. It looks like as we get infinitely far away from the Earth, the potential energy naturally goes to zero! Mathematically this makes sense. But we will have to interpret what this choice of zero-point means.

But first, let's see how much work it would take to move the moon out of orbit and move it farther away. Say, from  $R_1$ , the present orbit radius, to  $R_2 = 2R_1$ , or twice the original orbit distance. Then

$$\begin{aligned}
 \Delta U_g &= U_2 - U_1 = -G \frac{M_E m_m}{2R_1} + G \frac{M_E m_m}{R_1} \\
 &= G \frac{M_E m_m}{R_1} \left( -\frac{1}{2} + 1 \right) \\
 &= \left( \frac{1}{2} \right) G \frac{M_E m_m}{R_1}
 \end{aligned}$$

The change is positive. We gained potential energy as we went farther from the Earth's surface. That makes sense! That is analogous to increasing  $y$  in  $mgy$ . The potential energy also gets larger if the mass of our object (like the moon or a satellite) gets larger. Again that makes sense because in our more familiar approximation the potential energy increases with mass. So this new form for our equation for potential energy seems to work.

But what does it mean that the potential energy is zero infinitely far away? Recall that a change in potential energy is an amount of work

$$W = -\Delta U$$

Usually we will consider the potential energy to be the amount of work it takes to bring the test mass  $m_o$  from infinitely far away (our zero point!) to the location where we want it. It is how much energy is stored by having the object in that position. Like how much energy is stored by putting a mass high on a shelf. For example we could bring the moon in from infinitely far away. Then

$$\Delta U_g = U_2 - U_1 = -G \frac{M_E m_m}{R_2} + G \frac{M_E m_m}{\infty}$$

$$U_2 = -G \frac{M_E m_m}{R_2}$$

This is how much potential energy the moon has as it orbits the Earth because it is high, above the Earth. But notice, this is a negative number! What can it mean to have a negative potential energy?

Question 223.29.3

We use this convention to indicate that the test mass,  $m_m$  is bound to the Earth. It would take an input of energy to get the moon free from the gravitational pull of the Earth. Here is the Moon potential energy plotted as a function of distance.

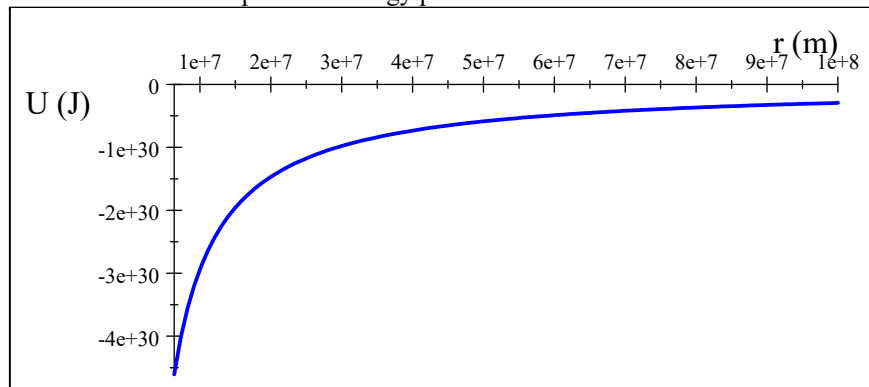

We can see that you have to go an infinite distance to overcome the Earth's gravity completely. That makes sense from our force equation. The force only goes to zero infinitely far away. When we finally get infinitely far away, there will be no potential energy due to the gravitational force because the gravitational force will be zero.

Of course, there are more than just two objects (Earth and Moon) in the universe, so as we get farther away from the Earth, the gravitational pull of, say, a galaxy, might dominate. So we might not notice the weak pull of the Earth as we encounter other nearer objects.

We should show that this form for the potential energy due to gravity becomes the more familiar  $m_m g h$  if our distances are small compared to the Earth's radius.

Let our distance from the center of the Earth be  $R_2 = R_E + y$  where  $R_E$  is the radius

of the Earth and  $y \ll R_E$ . Then

$$\begin{aligned} U &= -G \frac{M_E m_m}{R_2} \\ &= -G \frac{M_E m_m}{R_E + y} \end{aligned}$$

We can rewrite this as

$$\begin{aligned} U &= -G \frac{M_E m_m}{R_E \left(1 + \frac{y}{R_E}\right)} \\ &= -G \frac{M_E m_m}{R_E} \left(1 + \frac{y}{R_E}\right)^{-1} \end{aligned}$$

Since  $y$  is small  $y/R_E$  is very small and we can approximate the term in parenthesis using the binomial expansion

$$(1 \pm x)^n \approx 1 \mp nx \quad \text{if } x \ll 1$$

then we have

$$\left(1 + \frac{y}{R_E}\right)^{-1} \approx 1 - (-1) \frac{y}{R_E} \quad \text{if } \frac{y}{R_E} \ll 1$$

and our potential energy is

$$U = -G \frac{M_E m_m}{R_E} \left(1 + \frac{y}{R_E}\right)$$

then

$$\begin{aligned} U &= -G \frac{M_E m_m}{R_E} + G \frac{M_E m_m y}{R_E^2} \\ &= U_o + m_m \left(G \frac{M_E}{R_E^2}\right) y \end{aligned}$$

If we realize that  $U_o$  is the potential energy of the object at the surface of the Earth, then the change in potential energy as we lift the object from the surface to a height  $y$  is

$$\begin{aligned} \Delta U &= \left( U_o + m_m \left(G \frac{M_E}{R_E^2}\right) y - \left( U_o + m_m \left(G \frac{M_E}{R_E^2}\right) (0) \right) \right) \\ &= m_m \left(G \frac{M_E}{R_E^2}\right) y \end{aligned}$$

All that is left is to realize that

$$\left(G \frac{M_E}{R_E^2}\right)$$

has units of acceleration. This is just  $g$

$$g = \left(G \frac{M_E}{R_E^2}\right)$$

so we have

$$\Delta U = m_m g y$$

and there is no contradiction. But we should realize that this is an approximation. The more accurate version of our potential energy is

$$U_2 = -G \frac{M_E m_m}{R_2}$$

More importantly, we see that the field property,  $g$ , is being created by  $M_E$  because  $M_E$  is part of the defining equation.

Likewise we should expect that for charges

$$\Delta U_C = -q_m E d$$

is an approximation that is only good when the field,  $E$ , can be approximated as a constant magnitude and direction and that the distribution of charge,  $q$ , is not spatially too big. With this understanding, we can understand electrical potential energy of point charges.

### Point charges potential

Suppose we now take a positive charge and define its position as  $r = 0$  and place a negative mover charge near the positive charge.

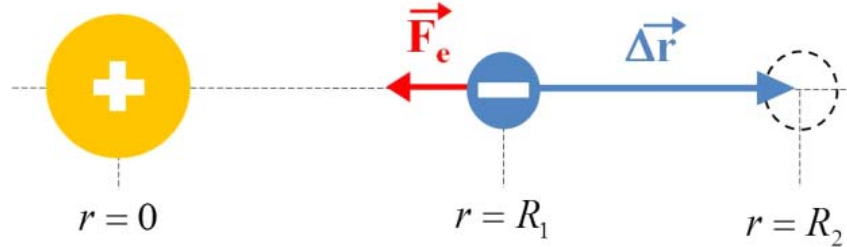

The work it would take to move the charge a distance  $\Delta r = R_2 - R_1$  would be

$$\Delta U_e = -W_e = - \int \vec{F}_e \cdot d\vec{r}$$

The magnitude of the electrical force is

$$F_e = \frac{1}{4\pi\epsilon_o} \frac{Q_E q_m}{r^2}$$

once again  $\vec{F}_e \cdot d\vec{r} = -F_e dr$  and

$$\begin{aligned} \Delta U_e &= - \int_{R_1}^{R_2} \left( -\frac{1}{4\pi\epsilon_o} \frac{Q_E q_m}{r^2} \right) dr \\ &= \frac{Q_E q_m}{4\pi\epsilon_o} \int_{R_1}^{R_2} \frac{dr}{r^2} \end{aligned}$$

and we realize that this is exactly the same integral we faced in the gravitational case.

The answer must be

$$\Delta U_e = -\frac{1}{4\pi\epsilon_o} \frac{Q_E q_m}{R_2} + \frac{1}{4\pi\epsilon_o} \frac{Q_E q_m}{R_1}$$

The similarity is hardly a surprise since the force equation for the Coulomb force is really just like the force equation for gravity.

It makes sense to choose the zero point of the electric potential energy the same way we did for the gravitational potential energy since the equations is the same. We will pick  $U = 0$  at  $r = \infty$ . Then we expect that

$$U_e = -\frac{1}{4\pi\epsilon_o} \frac{Q_E q_m}{r}$$

Question 223.29.4

is the electrical potential energy stored by having the charges in this configuration.

Again the negative sign shows that the two opposite charges will be bound together by the attractive force. Here is a graph of the electrical potential energy of an electron and a proton pair, like a Hydrogen atom.

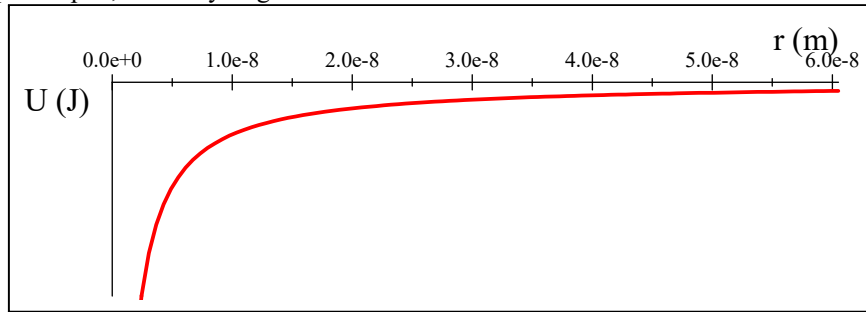

Of course we remember that there is a large difference between electrical and gravitational forces. If the two charges are the same sign, then they will repel and the potential must be different for that situation. If we redraw our diagram for this case, we realize that the sign of the force must change.

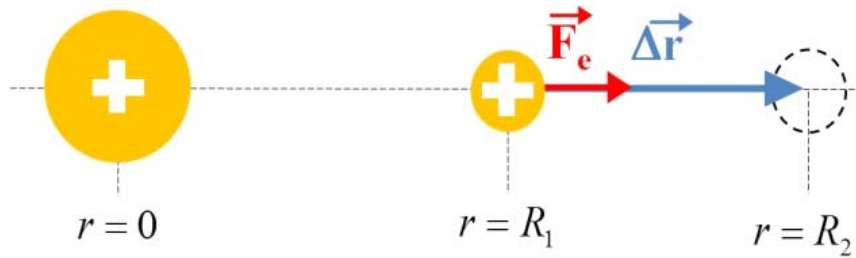

$$\Delta U_e = -W_e = -\int_{R_1}^{R_2} \left( +\frac{1}{4\pi\epsilon_o} \frac{Q_E q_m}{r^2} \right) dr$$

this will change all the signs in our solution

$$\Delta U_e = +\frac{1}{4\pi\epsilon_o} \frac{Q_E q_m}{R_2} - \frac{1}{4\pi\epsilon_o} \frac{Q_E q_m}{R_1}$$

then

$$U_e = +\frac{1}{4\pi\epsilon_o} \frac{Q_E q_m}{r}$$

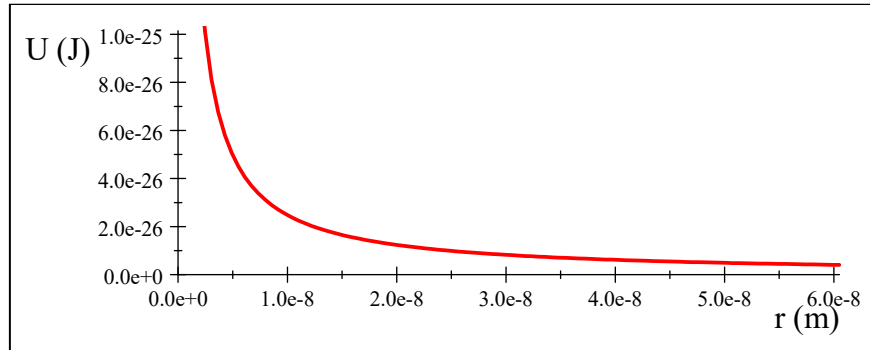

Now we can see that the potential energy gets larger as the two like charges get nearer. It takes energy to make them get closer. This is clearly not a bound situation.

### Three point charges.

Question 223.29.5

Suppose we have three like charges. What will the potential energy of the three-charge system be?

Let's consider the charges one at a time. If I move one charge,  $q_1$ , from infinitely far away, there is no environmental field electric, so there is no force, since we need two charges for there to be a force. Then there is no potential energy. This is like a rock floating in deep space far away from anything else in the universe. It just sits there, there is no potential for movement, so no potential energy. But when we bring in another charge,  $q_2$ , then  $q_1$  is an environmental charge making a field and  $q_2$  is our mover charge. Then  $q_2$  will take an amount of work equal to

$$U_{12} = \frac{1}{4\pi\epsilon_0} \frac{q_1 q_2}{r_{12}}$$

to move in the charge because the two charges repel each other. There is a force, so now there is an amount of potential energy associated with the work done to move the charges together.

Suppose we had chosen to bring in the other charge,  $q_3$ , instead. Charge  $q_1$  forms an environmental field. It takes an amount of energy

$$U_{13} = \frac{1}{4\pi\epsilon_0} \frac{q_1 q_3}{r_{13}}$$

to bring in the third charge. But if the second charge were already there, the second charge also creates an environmental field, so it also creates a force on the third charge. So it will take more work to bring in the third charge.

$$U_3 = \frac{1}{4\pi\epsilon_0} \frac{q_1 q_3}{r_{13}} + \frac{1}{4\pi\epsilon_0} \frac{q_2 q_3}{r_{23}}$$

So the total amount of work involved in bringing all three charges together

$$U = \frac{1}{4\pi\epsilon_0} \frac{q_1 q_2}{r_{12}} + \frac{1}{4\pi\epsilon_0} \frac{q_1 q_3}{r_{13}} + \frac{1}{4\pi\epsilon_0} \frac{q_2 q_3}{r_{23}}$$

then the potential energy difference would be

$$\begin{aligned} \Delta U &= U_f - U_i = -W \\ &= U_f - 0 \\ &= \frac{1}{4\pi\epsilon_0} \frac{q_1 q_2}{r_{12}} + \frac{1}{4\pi\epsilon_0} \frac{q_1 q_3}{r_{13}} + \frac{1}{4\pi\epsilon_0} \frac{q_2 q_3}{r_{23}} \end{aligned}$$

which we can generalize as

$$U = \frac{1}{4\pi\epsilon_0} \sum_{i < j} \frac{q_i q_j}{r_{ij}}$$

for any number of charges. We simply add up all the potential energies. This is one reason to use electric potential energy in solving problems. The electric potential energies just add, and they are not vectors, so the addition is simple.

## Dipole potential energy

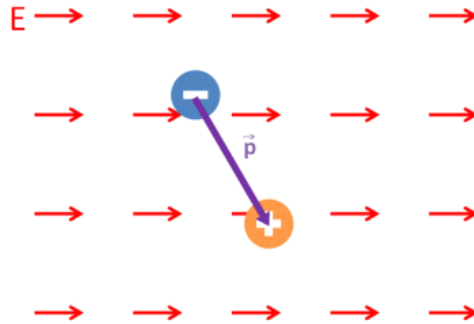

Let's try out our new idea of potential energy for point charges on a dipole. We will try to keep this easy, so let's consider the dipole to be in a constant, uniform electric field. We know there will be no net force. The work done to move a charge we have stated to be

$$W = \int \vec{\mathbf{F}}_e \cdot d\vec{\mathbf{r}}$$

but in this case, we know the net force on the dipole is zero.

However, we can also do some work in rotating something

$$W_{rot} = \int \tau_e d\theta$$

we know from before that the magnitude of the torque is

$$\tau = pE \sin \theta$$

so

$$\begin{aligned} W_{rot} &= \int_{\theta_1}^{\theta_2} pE \sin \theta d\theta \\ &= pE (\cos \theta_2 - \cos \theta_1) \end{aligned}$$

this must give

$$\begin{aligned} \Delta U &= -W_{rot} = U_f - U_i \\ &= -pE (\cos \theta_2 - \cos \theta_1) \end{aligned}$$

then we can write as

$$U = -pE \cos \theta$$

This is the rotational potential energy for the dipole. We can write this as an inner product

$$U = -\vec{p} \cdot \vec{E}$$

What does this mean? It tells us that we have to do work to turn the dipole.

Let's go back to our example of a microwave oven. If the field is  $E = 200 \text{ V/m}$ , then how much work does it take to turn the water molecules?

Remember that the dipole moment for a water molecule is something like

$$p_w = 6.2 \times 10^{-30} \text{ C m}$$

so we have

$$\begin{aligned} U &= -(6.2 \times 10^{-30} \text{ C m})(200 \text{ V/m}) \cos \theta \\ &= -1.24 \times 10^{-27} \text{ J} \cos \theta \end{aligned}$$

This is plotted in the next figure.

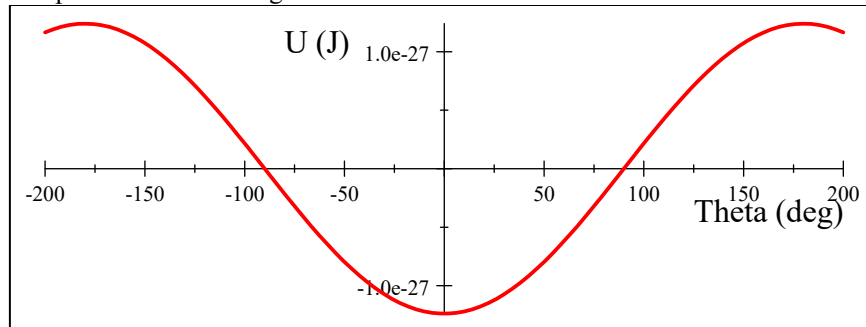

At zero degrees we can see that it takes energy (work) to make the dipole spin. It will try to stay at zero degrees and a small displacement from zero degrees will



will cause the dipole to oscillate around  $\theta = 0$  but it will return to  $\theta = 0$  as the added energy is dissipated. then  $\theta = 0$  rad is a stable equilibrium. Conversely, at  $\theta = \pi$  rad we are at a maximum potential energy. We get rotational kinetic energy if we cause any small displacement  $\Delta\theta$ . The dipole will angularly accelerate.  $\theta = \pm\pi$  rad is an unstable equilibrium.

## Shooting $\alpha$ -particles

Let's use electric potentials to think about a famous experiment. Ernest Rutherford shot  $\alpha$ -particles,  $q = +2q_e$  at gold nuclei,  $q = +79q_e$ . How close will the  $\alpha$ -particles get if the collision is head-on and the initial speed of the  $\alpha$ -particles is  $3 \times 10^6$  m/s?

The easiest way to approach this is to use conservation of energy. The energies before and after must be the same because we have no frictional or dissipative forces. The  $\alpha$ -particle, of course, is our mover.

The before and after pictures are as shown.

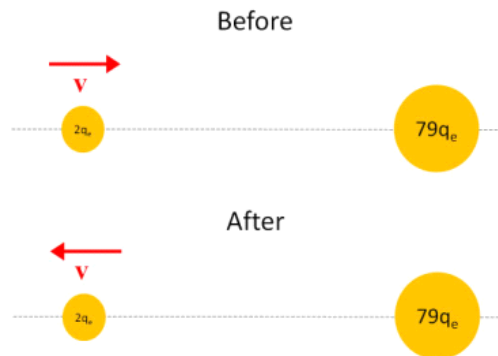

We can write

$$K_i + U_i = K_f + U_f$$

when the  $\alpha$ -particles are at their closest distance to the gold nuclei, then  $K_f = 0$ . We can envision starting the  $\alpha$ -particles from effectively an infinite distance away. Then  $U_i \approx 0$ . so

$$\frac{1}{2}m_\alpha v^2 = \frac{1}{4\pi\epsilon_0} \frac{Q_{Au}q_\alpha}{r}$$

Solving for  $r$  gives

$$\begin{aligned} r &= \frac{1}{4\pi\epsilon_o} \frac{Q_{Au}q_\alpha}{\frac{1}{2}m_\alpha v^2} \\ &= \frac{1}{2\pi\epsilon_o} \frac{(79q_e)(4q_e)}{m_\alpha v^2} \end{aligned}$$

then

$$\begin{aligned} r &= \frac{1}{2\pi \left(8.85 \times 10^{-12} \frac{\text{C}^2}{\text{Nm}^2}\right)} \frac{158 (1.602 \times 10^{-19} \text{C})^2}{(6.6422 \times 10^{-27} \text{kg}) (3 \times 10^6 \text{m/s})^2} \\ &= 1.2198 \times 10^{-12} \text{m} \end{aligned}$$

This is a very small number! and it sets a bound on how large the nucleus of the gold atom can be.

Next lecture, we will try to make our use of electrical potential energy more practical by defining the electrical potential energy per unit charge, and applying this to problems involving moving charges (like those in electric circuits).

## Basic Equations

# 11 Electric Potentials

## Fundamental Concepts

- Electric potential is a representation of the electric field environment.
- Electric potential is defined as the potential energy per unit charge.
- Equipotential lines are drawn to show constant electric potential surfaces
- The volt as a measure of electric potential
- The electron-volt as a measure of energy (and speed).

## Electric Potential

We defined electrical potential energy last time.

$$U_e = -\frac{1}{4\pi\epsilon_o} \frac{Q_E q_m}{r}$$

This is a quantity that depends on two charges, the environmental charge  $Q_E$  and the mover charge  $q_m$ . This is a lot like electric force

$$\vec{\mathbf{F}}_e = \frac{1}{4\pi\epsilon_o} \frac{Q_E q_m}{r^2} \hat{\mathbf{r}}$$

If you will recall, we split the force into an environmental part and a mover part

$$\vec{\mathbf{F}}_e = q_m \left( \frac{1}{4\pi\epsilon_o} \frac{Q_E}{r^2} \right) \hat{\mathbf{r}}$$

$$\vec{\mathbf{F}}_e = q_m \vec{\mathbf{E}}$$

where  $E$  is the electric field. We can do the same for the electric potential energy

$$U_e = -q_m \left( \frac{1}{4\pi\epsilon_o} \frac{Q_E}{r} \right)$$

where charge  $q_m$  is our mover charge. By analogy, then

$$\left( \frac{1}{4\pi\epsilon_o} \frac{Q_E}{r} \right)$$

must represent the environment set up by  $Q_E$ . And sure enough, it has a  $Q_E$  in it. But this does not have the units of electric field. So it must be a new quantity. We will need a name for this new representation of the environment created by  $Q_E$ .

Let's give a symbol and a name to our new environment quantity.

$$V_E = \frac{1}{4\pi\epsilon_o} \frac{Q_E}{r_{Em}}$$

where we understand that  $Q_E$  is making the environment and we are measuring that environment a distance  $r_{Em}$  from  $Q_E$  to the mover charge  $q_m$ .

Then

$$\begin{aligned} U_e &= -q_m \left( \frac{1}{4\pi\epsilon_o} \frac{Q_E}{r} \right) \\ &= -q_m (V_E) \end{aligned}$$

It's traditional to drop the subscripts on the  $V$

$$V = \frac{1}{4\pi\epsilon_o} \frac{q}{r}$$

where we understand that an environmental charge labeled just  $q$  is making the environment and  $r$  is a distance  $r$  from  $q$  to the location where we want to know the environment. In that case we can write

$$U_e = q_m (V)$$

or

$$V = \frac{U_e}{q_m}$$

This new environment representation appears to be an amount of potential energy per unit charge. In general any electrical potential energy ( $U$ ) per unit charge ( $q$ ) is called an *electric potential*.

$$V = \frac{U}{q}$$

This is a somewhat unfortunate name, because it sounds like electric potential energy. But it is not, it is a representation of the environment set up by the electric field. We don't get electric potential energy without multiplying by a charge.  $U = Vq_o$ . We can think of  $U$  as the electrical potential energy and  $V$  as needing something beyond itself ( $q$ ) to be an electric potential energy, so it is just an electric potential (no "energy" in the name) because it needs this extra piece.

## Electric Potential Difference

We will give electric potential the symbol  $V$  but usually the important quantity is a change in potential energy, then

$$\Delta V = \frac{\Delta U}{q} \tag{11.1}$$

If I know  $\Delta V$  for a configuration of charge (like our capacitor plates) then I can find

the  $\Delta U$  of different charges by multiplying by the amount of charge in each case

$$\Delta U_1 = q_1 \Delta V$$

$$\Delta U_2 = q_2 \Delta V$$

$$\vdots$$

which is convenient if I am accelerating many different charges. We do this in linear accelerators or “atom smashers” so this is important to physicists! We can see that the units of  $\Delta V$  must be

$$\frac{\text{J}}{\text{C}} = \text{V} \quad (11.2)$$

which has been named the *Volt* and is given the symbol, V.

Now this may seem familiar. Can you think of anything that carries units of volts? Let’s consider a battery. In our clickers we have 1.5 volt batteries. Inside the battery we would expect that a charge would experience a potential energy difference. We buy the battery so we can convert that potential energy into some other form of energy (radio wave energy for our clickers). The potential energy achieved depends on the charge carrier. We would have electrons in metals but we would have ions in a solution. This is so convenient to express the potential energy per unit charge, that it is the common form or expressing the energy given by most electrical sources.

Question 223.30.2

Question 223.30.3

## Electric Potential

Let’s write out the electric potential difference between points  $A$  and  $B$ . It is the change in potential energy per unit charge as the charge travels from point  $A$  to point  $B$

$$\Delta V = V_B - V_A = \frac{\Delta U}{q} \quad (11.3)$$

This is clearly a measure of how the environment changes along our path from  $A$  to  $B$ .

Let’s reconsider gravitational potential energy. We remember that if the field is uniform (that is, if we are near the Earth’s surface so the field seems uniform) we can set the zero point of the potential energy anywhere we find convenient for our problem, with the provision that once it is set for the problem, we have to stick with our choice.

One logical choice for many electrical appliances is to set the Earth’s potential equal to zero. Note! this is not true for point mass problems where we have already set the potential energy  $U = 0$  at  $r = \infty$ . In our gravitational analogy, this is a little bit like mean sea level. Think of river flow. The lowest point on the planet is not mean sea level. But any water above mean sea level will tend to flow downward to this point. Of course, if we have land below mean sea level, the water would tend to continue

downward (like water flows to the Dead Sea). The direction of water flow is given by the potential energy difference, not that actual value of the potential energy. It is the same way with electric potential. If we have charge at a potential that is higher than the Earth's potential, then charge will flow toward the Earth.

Question 223.30.4

Consider a 9 V battery. If the negative terminal is connected to a grounding rod or metal water pipe, it will be at the electric potential of the Earth while its positive terminal will be at  $\Delta V = 9 \text{ V}$  above the Earth's potential. Likewise, in your home, you probably have a 110 V outlet. One wire is likely set to the potential of the Earth by connecting it to a ground rod. The other is at  $\Delta V = 110 \text{ V}$  above it.

In our clickers, we don't have a ground wire, so we cannot guarantee that the negative terminal of the battery is at the same potential as the Earth. If our appliances in our house are not all grounded to the same potential, there is a danger that there will be a large enough difference in their potentials (think potential energy per unit charge) to cause the charges to accelerate from one appliance to another. It is the difference in potential that counts! This is a spark or shock that could hurt someone or damage equipment. That is why we now use grounded outlets. These outlets have a third wire that is tied to all the other outlet's third wire and also tied physically to the ground near your house or apartment. This way, all appliances are ensured to have the same low electric potential point.

### Example, potential of a capacitor

Let's calculate the potential of our favorite device, the capacitor.

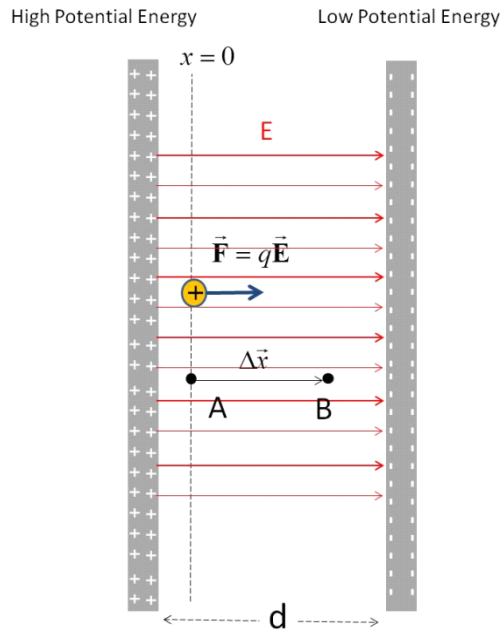

The nice uniform field makes this a useful device for thinking about electric potentials. We have found that field to be

$$E = \frac{\eta}{\epsilon_0}$$

with a direction from positive to negative. The work to push a mover charge from one side to the other is given by

$$W = \int F_e \cdot dx$$

The force is uniform since the field is uniform (near the middle at least)

$$F_e = q_m E$$

then our work becomes

$$\begin{aligned} W &= \int q_m E \cdot dx \\ &= q_m E \Delta x \end{aligned}$$

and the amount of potential energy is

$$|\Delta U| = | -q_m E \Delta x |$$

We can set the zero potential energy point anywhere we want, but it is tradition to set  $U = 0$  at the negative plate. If we do this we end up with the potential energy difference going from the negative plate to the positive plate being

$$\Delta U = q_m E d$$

Then if we go from the negative plate to the positive plate we have a positive  $\Delta U$ .

We have seen all this before when we compared the electric potential energy of a uniform gravitation field and a uniform electrical field. Now let's calculate the electric potential difference

$$\Delta V = \frac{\Delta U}{q_m} = \frac{q_m E d}{q_m} = E d$$

Remember that the field is created by the charges on the capacitor plates, so it exists whether we put any  $q_o$  inside of the capacitor or not. Then the potential difference must exist whether or not there is a charge  $q_o$  inside the capacitor.

You probably already know that a voltmeter can measure the electric potential difference between two points, say, the plates of a capacitor. If we use such a meter we could find the field inside the capacitor (well, almost, remember our approximation is good for the center of the plates).

$$E = \frac{\Delta V}{d}$$

## Equipotential Lines

Question 223.30.5

We need a way to envision this new environmental quantity that, like a field, has a value throughout all space. Our analogy with gravity gives us an idea. Suppose we envision the height potential energy as the top of a hill. Then the low potential energy would be the bottom of the hill. We know from our Boy Scout and Girl's Camp experiences how to show a change in gravitational potential energy. We plot on a map lines of constant potential energy. We call it constant elevation, but since near the Earth's surface  $U_g = mgh$  the potential energy is proportional to the height, so we can say these lines are lines of constant potential energy. Here is an example for Mt. Shasta.

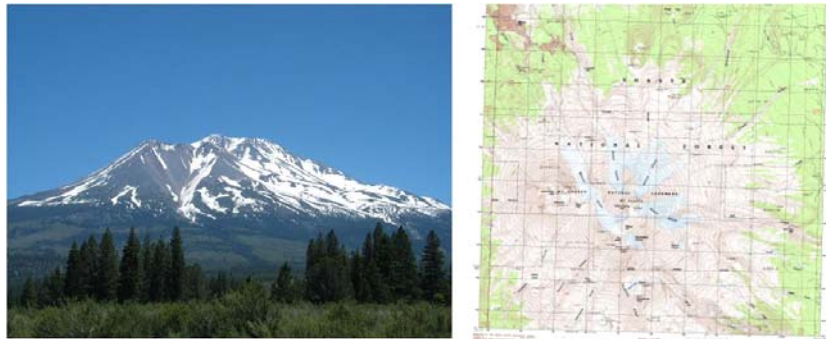

Map courtesy USGS, Picture is in the Public Domain.

We can think of these lines of constant potential energy as paths over which the



gravitational field does no work. If we walked along one of these lines we would get neither higher nor lower and though we might do work to overcome some friction, the gravitational field would do no work. And we would do no work in changing elevation.

Question 223.30.6

Likewise we can draw lines of equal potential for our capacitor. When moving along these lines the electric field would do no work.

Equipotential Surfaces

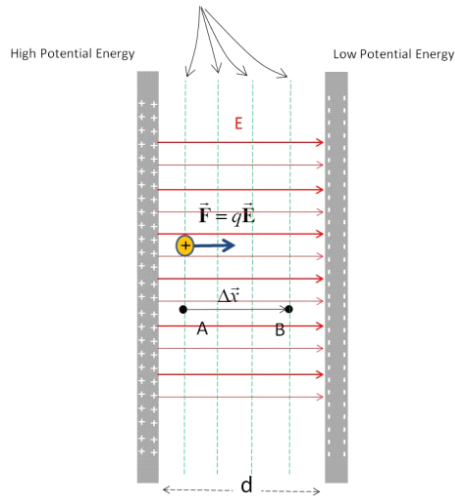

Of course we could draw these lines for a crazier device. Say, for our charged conductor

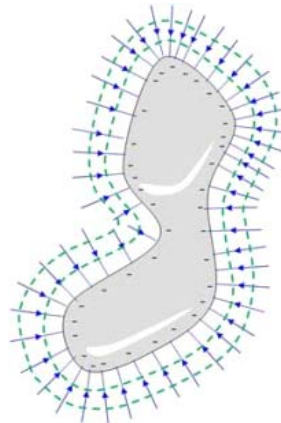

Notice that our equal potential lines are always perpendicular to the field. From

$$W = \int q_o \vec{E} \cdot d\vec{x}$$

we can see that if the path we travel is perpendicular to the field, no work is done. This is like us marching along around the mountain neither going up nor down.

## Electron Volt

Suppose I set up our uniform electric field device again

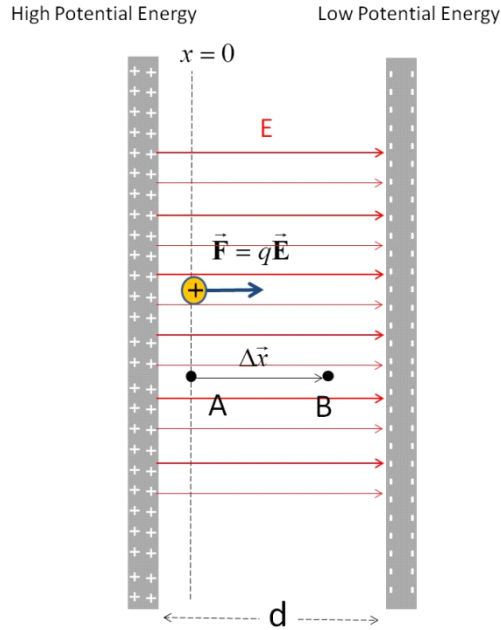

We are not including any gravitational field, so the directions involved are all relative to the placement of the capacitor plate orientation.

This time, suppose I make the potential difference  $\Delta V = 1 \text{ V}$ . I release a proton near the high potential side. What is the kinetic energy of the proton as it hits the low potential side? From the work energy theorem

$$W_{nc} = \Delta K + \Delta U$$

and if we do this in a vacuum so there is no non-conservative work,

$$\Delta K = -\Delta U$$

$$K_f - K_i = -\Delta U$$

$$K_f = -\Delta U$$

We can find the potential energy loss from what we just studied

$$\Delta V = \frac{\Delta U}{q_m}$$

so we can find the potential energy as

$$\Delta U = q_m \Delta V$$

but remember we are going from a high to a low potential

$$\Delta V = V_f - V_i$$

this will be negative, so the potential energy change will be negative too.

$$\begin{aligned} K_f &= -\Delta U \\ &= -q_m \Delta V \end{aligned}$$

which will be a positive value (which is good, because I don't know what negative kinetic energy would mean).

$$K_f = -q_m \Delta V$$

We can find the amount of energy in Jules

$$\begin{aligned} K_f &= (1.6 \times 10^{-19} \text{ C}) (1 \text{ V}) \\ &= 1.6 \times 10^{-19} \text{ J} \end{aligned}$$

since we defined a volt as  $V = \frac{\text{J}}{\text{C}}$ .

You might think this is not very useful, but remember that  $K = \frac{1}{2}mv^2$ . The kinetic energy is related to how fast the proton is going. In a way, the kinetic energy tells us how fast the particle is going (we know it's mass). If you read about the Large Hadron Collider at CERN, in Switzerland the "speeds" of the particles will be given in energy units that are multiples of  $1.6 \times 10^{-19} \text{ J}$ . We call this unit an electron-volt (eV).



Beam magnet and Section of the Beam Pipe of the LHC. This section is actually no longer used and is in a service area 100 m above the operating LHC. The people you see are part of a BYU-I Physics Department Tour of the facility.

We can finish this problem by finding the speed of the particle

$$K = \frac{1}{2}mv^2$$

so

$$\frac{2K}{m} = v^2$$

or

$$\begin{aligned} v &= \sqrt{\frac{2K}{m}} \\ &= \sqrt{\frac{2(1.6 \times 10^{-19} \text{ J})}{1.00728 \text{ u} \frac{1.6605 \times 10^{-27} \text{ kg}}{1 \text{ u}}}} \\ &= 13832. \frac{\text{m}}{\text{s}} \end{aligned}$$

Which is pretty fast, but the Large Hadron Collider at CERN can provide energies up to  $7 \times 10^{14}$  eV which would give our proton a speed of 99.999991% of the speed of light.



CERN CMS detector during a maintenance event. The bright metal pipe seen in the middle of the detector is the beam pipe through which the accelerated protons travel.

Note the workers near the scaffolding for scale.

Note that this energy would seem to provide a faster speed—faster than light! But with energies this high we have to use Einstein's theory of Special Relativity to calculate the particle speed. And, sadly, that is not part of this class. If you are planning to work on the GPS system, or future space craft, you might need to take yet another physics class so you can do this sort of calculation.

You might guess that we will want to know the electric potential of more complex configurations of charge. We will take on this job in the next lecture.

## Basic Equations

The electric potential is the electrical potential per unit charge

$$\Delta V = V_B - V_A = \frac{\Delta U}{q_m}$$

For the special case of a constant electric field in a capacitor the electrical potential is just

$$\Delta V = E\Delta s$$

where  $\Delta s$  is the distance traveled from one side of the capacitor to the other.

The unit

$$1 \text{ eV} = 1.6 \times 10^{-19} \text{ J}$$



# 12 Electric potential of charges and groups of charges

Now that we have a new representation of the environment created by environmental charges, we will need to be able to calculate values for that representation for different configurations of charge like we did for electrical fields. But there is a huge benefit in using the electric potential representation, electric potentials are not vectors! So we don't have to deal with the vector nature of the field environment. The vector nature is still there, but we will ignore it. This means we will give up being able to give up vector directions for movement of our mover charges in many cases. But we can know much about the movement and the equations will be much simpler. We will take on the usual cases of environments from a point charge, a collection of point charges, and a continuous distribution of charges.

## Fundamental Concepts

- Finding the electric potential of a point charge
- Finding the electric potential of two point charges
- Finding the electric potential of many point charges
- Finding the electric potential of continuous distributions of point charges.

## Point charge potential

The capacitor was an easy electric potential to describe. Let's go back to a slightly harder one, the potential due to just one point charge. The potential energy depends on two charges

$$U_e = -\frac{1}{4\pi\epsilon_o} \frac{Q_E q_m}{r}$$

but the potential just depends on one.

$$V = \frac{U}{q_m}$$

where  $U$  is a function of  $q_m$ , so the mover charge will cancel.

We say we have an electric potential due to the environmental charge even if the mover charge is not there. This is like saying there is a potential energy per unit rock, even if there is no rock to fall down the hill. The hill is there whether or not we are throwing rocks down it.

For electric potential, the potential is due to the field, and the field from the environmental charge is there whether another charge is there or not.

Let's find this potential due to just one charge, but let's find it in a way that demonstrates how to find potentials in any situation. After all, from what we know about point charges, we can predict that

$$V = \frac{U}{q_m} = \frac{\frac{1}{4\pi\epsilon_o} \frac{Q_E q_m}{r}}{q_m} = \frac{1}{4\pi\epsilon_o} \frac{Q_E}{r}$$

So finding the answer is not very hard. But not all situations come so easily. We only know forms for  $U$  for capacitors and point charges so far. So let's see how to do this in general, and compare our answer for the point charge with what we have guessed from knowing  $U$ .

Symmetry tells us the field will be radial, so the equipotential surfaces must be concentric spheres. Here is our situation:

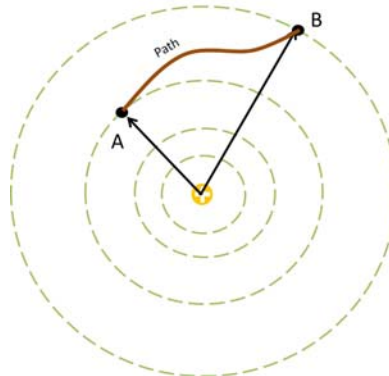

We wish to follow the marked path from  $A$  to  $B$  finding the potential difference  $\Delta V = V_B - V_A$ .

Remember that the field due to a charge  $q$  is radially outward from the charge. To find the potential we start with what we found last lecture, for a constant field

$$\Delta V = \frac{\Delta U}{q_m} = \frac{q_m E \Delta s}{q_m} = E \Delta s$$

where  $s$  is the path length along our chosen path from  $A$  to  $B$ . For our capacitor, this was just the distance from one side to the other, but here we need to be more general.



We should really write this as

$$\Delta V = \vec{E} \cdot \vec{\Delta s}$$

Further, our field,  $E$ , changes, so technically this value for  $\Delta V$  is not correct. But if we take very small paths,  $\Delta \vec{s}$ , then the field will be nearly constant over the small distances. Then we can add up the contribution of each small distance,  $\Delta \vec{s}_i$  to deal with the entire path from  $A$  to  $B$  for our point charge geometry.

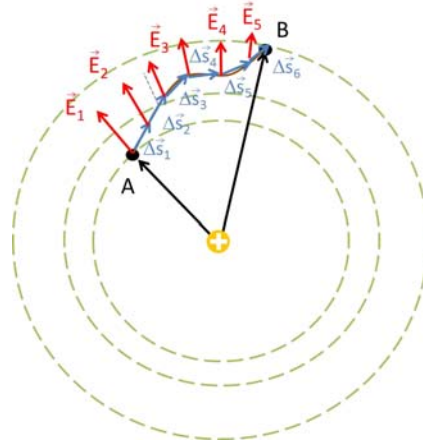

That is, we take a small amount of path difference  $\Delta \vec{s}_i$  and add up the contribution,  $\vec{E} \cdot \vec{\Delta s}_i$  from this small path. Then we can repeat this for the next  $\Delta \vec{s}_{i+1}$  and the next, until we have the contribution of each piece of the path. We can call the contribution from one piece.

$$\Delta V_i = \vec{E} \cdot \vec{\Delta s}_i$$

The total potential difference would be

$$\Delta V = \sum_i \vec{E} \cdot \vec{\Delta s}_i$$

In the limit that the  $\Delta s_i$  become very small this becomes an integral

$$\Delta V = - \int_A^B \vec{E} \cdot d\vec{s} \quad (12.1)$$

where  $A$  and  $B$  are any two points.

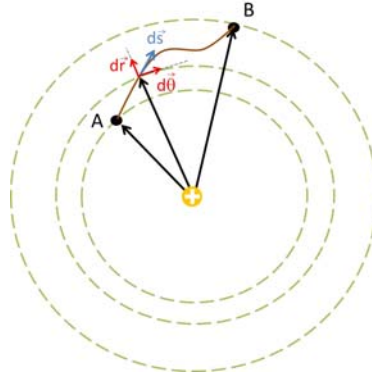

Here is an expansion of the region about A and B.

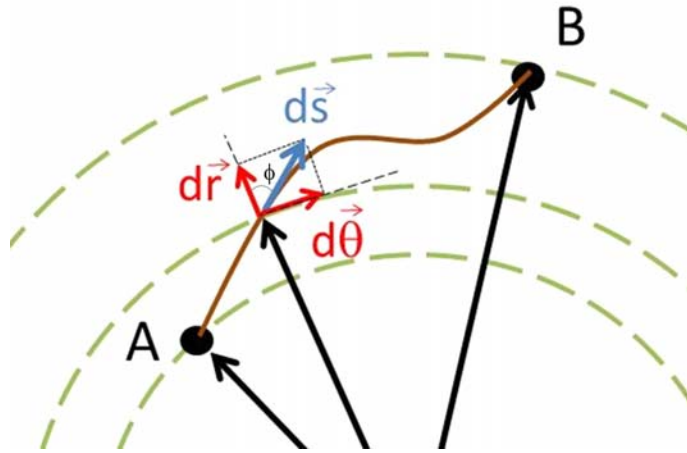

Let's divide up our  $d\vec{s}$  into components in the radial and azimuthal directions (polar coordinates)

$$d\vec{s} = (dr\hat{r} + rd\theta\hat{\theta})$$

from trigonometry we can see that

$$\cos \phi = \frac{dr}{ds}$$

(remember that  $dr$  and  $ds$  are lengths, infinitesimal lengths, but lengths just the same)

and

$$\sin \phi = \frac{rd\theta}{ds}$$

so

$$dr = ds \cos \phi$$

$$rd\theta = ds \sin \phi$$

and we can write

$$d\vec{s} = (ds \cos \phi \hat{r} + r ds \sin \phi \hat{\theta})$$

The field due to the point charge is

$$\vec{\mathbf{E}} = \frac{1}{4\pi\epsilon_o} \frac{q_E}{r^2} \hat{\mathbf{r}} \quad (12.2)$$

if we take

$$\begin{aligned} \vec{\mathbf{E}} \cdot d\vec{\mathbf{s}} &= \frac{1}{4\pi\epsilon_o} \frac{q_E}{r^2} \hat{\mathbf{r}} \cdot d\vec{\mathbf{s}} \\ &= \frac{1}{4\pi\epsilon_o} \frac{q_E}{r^2} \hat{\mathbf{r}} \cdot (ds \cos \phi \hat{\mathbf{r}} + ds \sin \phi \hat{\boldsymbol{\theta}}) \end{aligned}$$

we get only a radial contribution since  $\hat{\mathbf{r}} \cdot \hat{\boldsymbol{\theta}} = \mathbf{0}$ . Then

$$\begin{aligned} \vec{\mathbf{E}} \cdot d\vec{\mathbf{s}} &= \frac{1}{4\pi\epsilon_o} \frac{q_E}{r^2} \hat{\mathbf{r}} \cdot ds \cos \phi \hat{\mathbf{r}} + \mathbf{0} \\ &= \frac{1}{4\pi\epsilon_o} \frac{q_E}{r^2} ds \cos \phi \end{aligned}$$

where  $\phi$  is the angle between  $d\vec{\mathbf{s}}$  and  $\hat{\mathbf{r}}$  and where we recall that  $\hat{\mathbf{r}} \cdot \hat{\mathbf{r}} = 1$ . Recalling that

$$dr = ds \cos \phi$$

we can eliminate  $\phi$  from our equation

$$\vec{\mathbf{E}} \cdot d\vec{\mathbf{s}} = \frac{1}{4\pi\epsilon_o} \frac{q_E}{r^2} dr$$

and we can integrate this!

$$\begin{aligned} \Delta V &= - \int_{r_A}^{r_B} \frac{1}{4\pi\epsilon_o} \frac{q_E}{r^2} dr \\ &= - \frac{q_E}{4\pi\epsilon_o} \int_{r_A}^{r_B} \frac{1}{r^2} dr \\ &= \frac{q_E}{4\pi\epsilon_o} \frac{1}{r} \Big|_{r_A}^{r_B} \end{aligned}$$

so

$$\Delta V = \frac{q_E}{4\pi\epsilon_o} \left( \frac{1}{r_B} - \frac{1}{r_A} \right)$$

Question 223.31.1

Note that the potential depends only on the radial distances from the point charge—not the path. We would expect this for conservative fields.

We know that, like potential energy, we may choose our zero point for the electric potential. For a point charge, we often take the  $r_A = \infty$  point as  $V = 0$ . This is probably not a surprise, since  $U \rightarrow 0$  when  $r \rightarrow \infty$ . So you will often see the potential for the point charge written as just

$$\Delta V = \frac{1}{4\pi\epsilon_o} \frac{q_E}{r_B}$$

or simply as

$$V = \frac{1}{4\pi\epsilon_o} \frac{q_E}{r} \quad (12.3)$$

Here is a plot of this with  $q_E = 2 \times 10^{-9}$  C and the charge placed right at  $x = 10$  m.

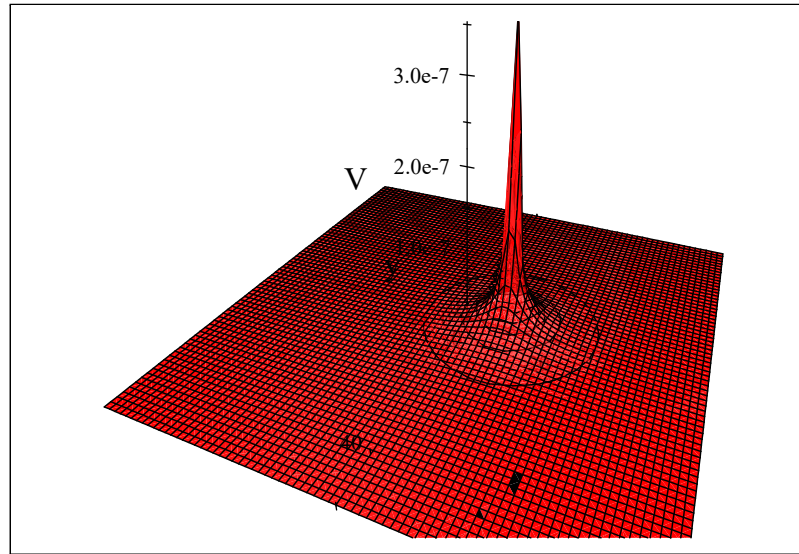

It is probably a good idea to state that in common engineering practice we kind of do all this backwards. We usually say we will charge up something until it has a particular voltage. This is because we have batteries or power supplies that are charge delivery services. They can provide enough charge to make some object have the desired voltage. By “desired voltage” we always mean the voltage at the conductor surface.

Early *electrodes* were spherical, so let’s consider making a spherical conductor have a particular potential at it’s surface. A sphere of charge with radius  $R$  would have

$$V = \frac{1}{4\pi\epsilon_o} \frac{Q_E}{R}$$

at it’s surface. We can guess this because Gauss’ law tells us that the field of a charged sphere is the same as that of a point charge with the same  $Q$ . Then it takes

$$Q_E = 4\pi\epsilon_o R V$$

to get the voltage we want. The battery or power supply must provide this. If the power supply or battery has a large amperage (ability to supply charge) this happens quickly. But away from the electrode the potential falls off. We can find how it falls off by again using

$$V = \frac{1}{4\pi\epsilon_o} \frac{Q_E}{r}$$

but with charge

$$Q_E = 4\pi\epsilon_o R V_o$$

so that

$$V = \frac{1}{4\pi\epsilon_o} \frac{4\pi\epsilon_o R V_o}{r}$$

or

$$V = \frac{R}{r} V_o$$

where  $V_o$  is the voltage at the surface. We can see that as  $r$  increases,  $V$  decreases.

## Two point charges

Question 223.31.2

Question 223.31.3

We can guess from our treatment of the potential energy of two point charges that the electric potential due to two point charges is just the sum of the individual point charge potentials.

$$\begin{aligned} V &= V_1 + V_2 \\ &= \frac{1}{4\pi\epsilon_o} \frac{q_1}{r_1} + \frac{1}{4\pi\epsilon_o} \frac{q_2}{r_2} \\ &= \frac{1}{4\pi\epsilon_o} \left( \frac{q_1}{r_1} + \frac{q_2}{r_2} \right) \end{aligned}$$

This is an environment created by two point charges. We could convert this to a potential energy by introducing a mover charge,  $q_m$ .

$$U = q_m \left( \frac{1}{4\pi\epsilon_o} \left( \frac{q_1}{r_1} + \frac{q_2}{r_2} \right) \right)$$

where both  $q_1$  and  $q_2$  are environmental charges.

It is instructive to look at the special case of two opposite charges (our dipole). We can plot the electric potential in a plane through the two charges.

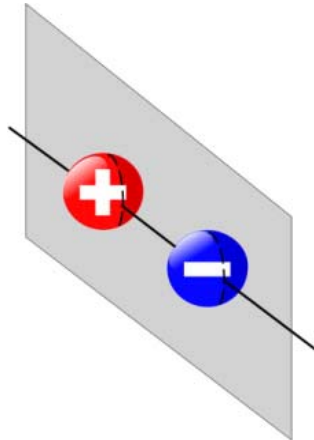

It would look like this

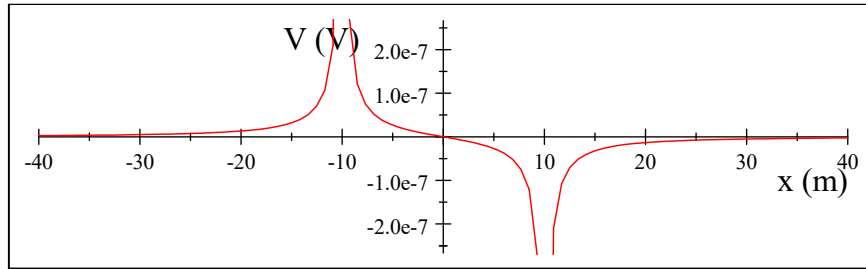

The charges ( $q = 2 \times 10^{-9}$  C) were placed right at  $x = \pm 10$  m. The potential

$$V = \frac{1}{4\pi\epsilon_0} \left( \frac{q_1}{r_1} + \frac{q_2}{r_2} \right)$$

becomes large near  $r_1 = R$  or  $r_2 = R$  where  $R$  is the charge radius (which is very small, since these are point charges). Plotting the potential in two dimensions is also interesting. We see that near the positive charge we have a tall mountain-like potential and near the negative charge we have a deep well-like potential.

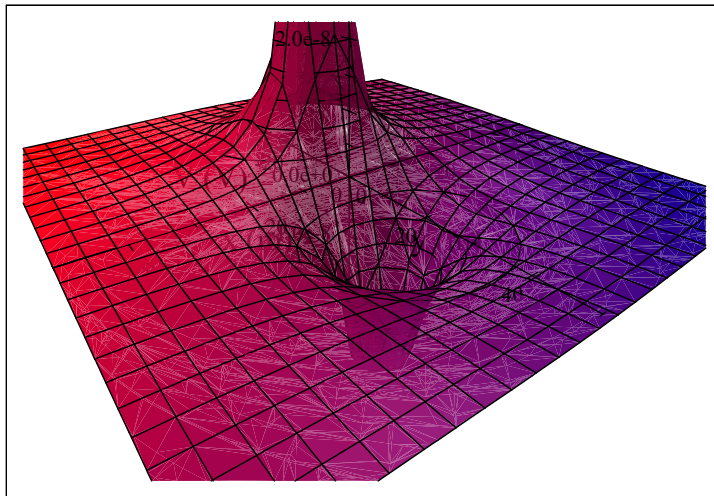

Notice the equipotential lines. The more red peak is the positive charge (hill), the more blue the negative charge (valley). A view from farther away looks like this

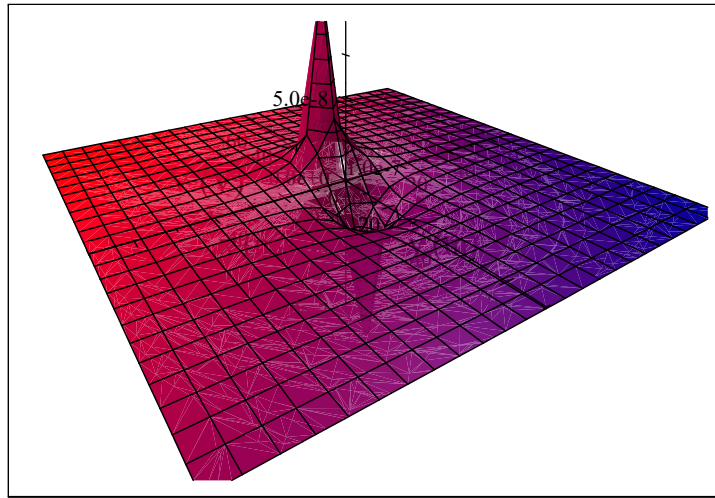

Of course the hill and the valley both approach an infinity at the point charge because of the  $1/r$  dependence.

### Lots of point charges

Question 223.31.4

Suppose we have many point charges. What is the potential of the group? We just use superposition and add up the contribution of each point charge

$$V = \frac{1}{4\pi\epsilon_0} \sum_i \frac{q_i}{r_i} \quad (12.4)$$

where  $r_i$  is the distance from the point charge  $q_i$  to the point of interest (where we wish to know the potential). Note that this is easier than adding up the electric field contributions. Electric potentials are not vectors! They just add as scalars.

Of course the electrical potential energy requires a mover charge. It would be

$$\begin{aligned} U &= q_m (V) \\ &= q_m \left( \frac{1}{4\pi\epsilon_0} \sum_i \frac{q_i}{r_i} \right) \end{aligned}$$

### Potential of groups of charges

Suppose we have a continuous distribution of charge. Of course, this would be made of many, many point charges, but if we have so many point charges that the distance between the individual charges is negligible, we can treat them as one continuous thing. If we know the charge distribution we can just interpret the distribution as a set of small

amounts of charge  $dq$  acting like point charges all arranged into some shape.

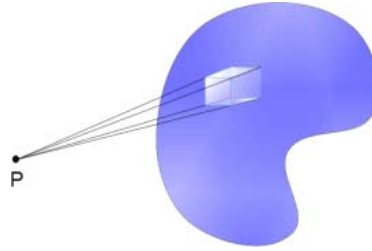

Then for each charge  $dq$  we will have a small amount of potential

$$dV = \frac{1}{4\pi\epsilon_0} \frac{dq}{r} \quad (12.5)$$

and the total potential at some point will be the summation of all these small amounts of charge

$$V = \frac{1}{4\pi\epsilon_0} \int \frac{dq}{r} \quad (12.6)$$

This looks a little like our integral for finding the electric field from a configuration of charge, but there is one large difference. There is no vector nature to this integral. So our procedure will have one less step

- Start with  $V = \frac{1}{4\pi\epsilon_0} \int \frac{dq}{r}$
- find an expression for  $dq$
- Use geometry to find an expression for  $r$
- Solve the integral

Let's try one together

### Electric potential due to a uniformly charged disk

We have found the field due to a charged disk. We can use our summation of the potential due to small packets of charge to find the electric potential of an entire charged disk.



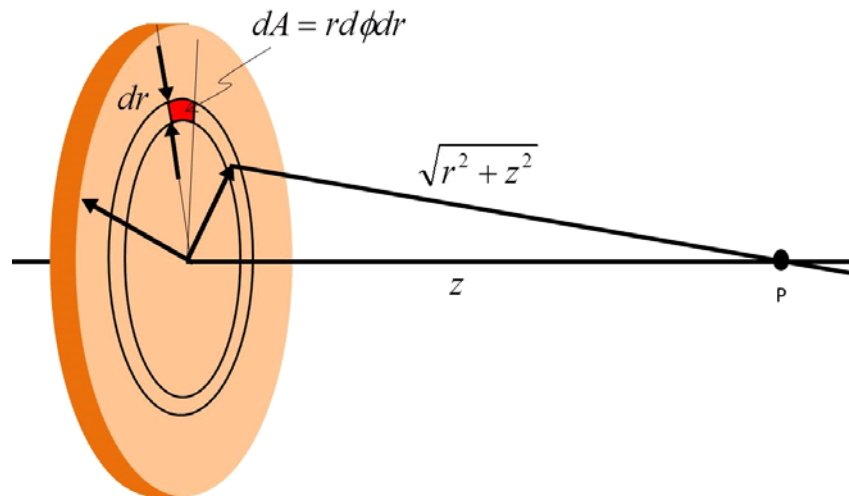

Suppose we have a uniform charge density  $\eta$  on the disk, and a total charge  $Q$ , with a disk radius  $a$ . We wish to find the potential at some point  $P$  along the central axis.

Question 223.31.5

To do this problem let's divide up the disk into small areas,  $dA$  each with a small amount of charge,  $dq$ . The area element is

$$dA = r d\phi dr$$

so the charge element,  $dq$ , is

$$dq = \eta r d\phi dr$$

For each  $dq$  we have a small part of the total potential. Let me use the variable  $R$  to be the distance from a part of the ring to the point  $P$ . Then  $R = \sqrt{r^2 + z^2}$  and our integral becomes

$$\begin{aligned} V &= \frac{1}{4\pi\epsilon_0} \int \frac{dq}{r} \\ &= \frac{1}{4\pi\epsilon_0} \int \int \frac{\eta r d\phi dr}{\sqrt{r^2 + z^2}} \end{aligned}$$

We will integrate this. We will integrate over  $r$  from 0 to  $a$  and  $\phi$  from 0 to  $2\pi$  which will account for all the charge on the disk, and therefore all the potential.

$$\begin{aligned}
 V &= \frac{1}{4\pi\epsilon_o} \int_0^{2\pi} \int_0^a \frac{\eta 2\pi r dr}{\sqrt{r^2 + z^2}} & (12.7) \\
 &= \frac{\eta 2\pi}{4\pi\epsilon_o} \int_0^a \frac{r dr}{\sqrt{r^2 + z^2}} \\
 &= \frac{\eta 2\pi}{4\pi\epsilon_o} \sqrt{r^2 + z^2} \Big|_0^a \\
 &= \frac{\eta 2\pi}{4\pi\epsilon_o} \sqrt{a^2 + z^2} - \frac{\eta 2\pi}{4\pi\epsilon_o} z
 \end{aligned}$$

so

$$V = \frac{\eta}{2\epsilon_o} \left( \sqrt{a^2 + z^2} - z \right) \quad (12.8)$$

This is the potential at point  $P$ .

We compared our electric field solutions with the solution for a point charge. We can do the same for electric potentials. We can compare our solution to a point charge potential for an equal amount of charge. Far away from the disk, we expect the two potentials to look the same. The point charge equation is

$$V = \frac{Q}{4\pi\epsilon_o} \frac{1}{z}$$

Our disk gives

$$V = \frac{Q}{4\epsilon_o\pi a^2} \left( \sqrt{a^2 + z^2} - z \right) \quad (12.9)$$

They don't look much alike! But plotting both yields

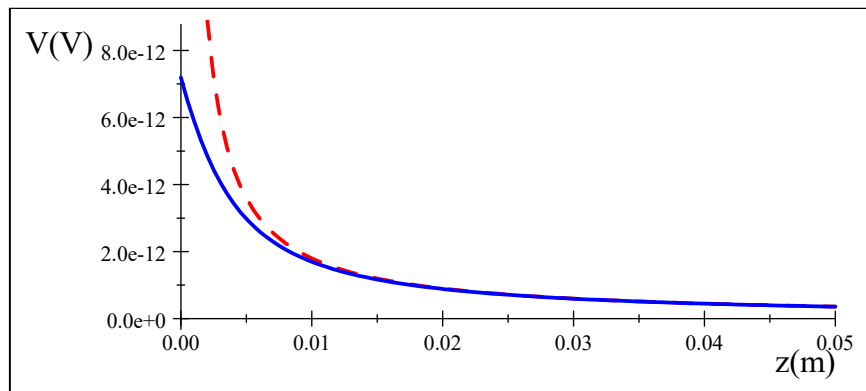

The dashed line is the point charge, the solid line is our disk with a radius of 0.05 m and a total charge of 2 C. This shows that far from the disk the potential is like a point charge, but close the two are quite different as we would expect. This is a reasonable result.

We will calculate the potential due to several continuous charge configurations.

But, you may ask, since we knew the field for the disk of charge, couldn't we have found the electric potential from our equation of the field? We will take up this question in the next two lectures.

## Basic Equations

The electric potential of a point charge is given by

$$V = \frac{1}{4\pi\epsilon_0} \frac{Q}{r}$$

where the zero potential point is set at  $r = \infty$ .

Electric potentials simply add, so the potential for a collection of point charges is just

$$V = \frac{1}{4\pi\epsilon_0} \sum_i \frac{q_i}{r_i}$$

To find the potential due to a continuous distribution of charge we use the following procedure:

- Start with  $V = \frac{1}{4\pi\epsilon_0} \int \frac{dq}{r}$
- find an expression for  $dq$
- Use geometry to find an expression for  $r$
- Solve the integral



# 13 Potential and Field

Since electric fields and electric potentials are both representations of the environment created by the environmental charge, there must be a way to calculate the potential from the field and *vice versa*. It will take us two lectures to do both.

## Fundamental Concepts

- The potential and the field are manifestations of the same physical thing
- We find the potential from the field using  $\Delta V = - \int \vec{\mathbf{E}} \cdot d\vec{\mathbf{s}}$
- Fields and potentials come from separated charge

## Connecting potential and field

It is time to pause and think about the meaning of this electric potential. Let's trace our steps backwards. We defined the electric potential as the potential energy per unit charge:

Question 223.32.1

$$\Delta V = \frac{\Delta U}{q_m}$$

where  $q_m$  is our mover and  $\Delta V$  is a measure of the change in the environment between two points  $r_1$  and  $r_2$  measured from the environmental charge.  $\Delta U$  is the change in potential energy as  $q_m$  moves. But the potential energy change is equal to the negative of the amount of work we have done in moving  $q_m$

Question 223.32.2

$$\Delta V = \frac{-W}{q_m}$$

which is equal to

$$\Delta V = \frac{-1}{q} \int \vec{\mathbf{F}} \cdot d\vec{\mathbf{s}}$$

where again  $d\vec{\mathbf{s}}$  is a general path length. But this force was a Coulomb force, which we know is related to the electric field

$$\vec{\mathbf{E}} = \frac{\vec{\mathbf{F}}}{q_m}$$

so we may rewrite the potential as

$$\begin{aligned}\Delta V &= - \int \frac{\vec{\mathbf{F}}}{q} \cdot d\vec{\mathbf{s}} \\ &= - \int \vec{\mathbf{E}} \cdot d\vec{\mathbf{s}}\end{aligned}$$

Question 223.32.3

which we found last lecture by analogy with our capacitor potential. Our line of reasoning in this lecture has been more formal, but we arrive at the same conclusion—**and it is an important one!** If we add up the component of field magnitude times the displacement along the path take from  $r_1$  to  $r_2$  we get the electric potential (well, minus the electric potential).

The electric field and the electric potential are not two distinct things. They are really different ways to look at the same thing—and that thing is the environment set up by the environmental charge. It is tradition to say the electric field is the principal quantity. This is because we have good evidence that the electric field *is* something. That evidence we will study at the end of these lectures, but in a nutshell it is that we can make waves in the electric field. If we can make waves in it, it must be something!<sup>12</sup>

in our gravitational analogy, the gravitational field is the real thing. Gravitational potential energy is a result of the gravitational field being there. The change in potential energy is an amount of work, and the gravitational force is what does the work. No force, no potential energy. The gravitational field makes that force happen.

It is the same for our electrical force. The electrical potential is due to the Coulomb force, and the Coulomb force exists because the electric field is there.

If the field and the potential are really different manifestations of the same thing, we should be able to find one from the other. We have one way to do this. We can find the potential from the field, but we should be able to find the field from the potential. We will practice the first

$$\Delta V = - \int \vec{\mathbf{E}} \cdot d\vec{\mathbf{s}}$$

today, and then introduce how to find the field from the potential next lecture.

### Finding the potential from the field.

Actually we did an example last lecture. We found the field of a point charge. But let's

<sup>12</sup> By the end of these lectures, we will try to make this a more convincing (and more mathematical) statement!

take on some harder examples in this lecture.

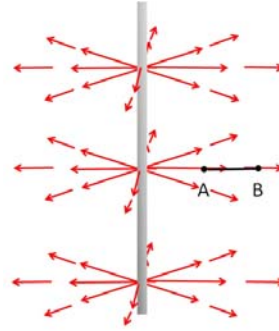

Let's calculate the electric potential due to an infinite line of charge. This is like the potential due to a charged wire. We already found the field due to an infinite line of charge

$$E = \frac{1}{4\pi\epsilon_0} \frac{2\lambda}{r} \hat{\mathbf{r}}$$

so we can use this to find the potential difference.

$$\Delta V = - \int_A^B \vec{\mathbf{E}} \cdot d\vec{\mathbf{s}}$$

We need  $d\vec{\mathbf{s}}$ . Of course  $d\vec{\mathbf{s}}$  could be in any direction. We can take components in cylindrical coordinates

$$d\vec{\mathbf{s}} = dr\hat{\mathbf{r}} + rd\theta\hat{\boldsymbol{\theta}} + dz\hat{\mathbf{z}}$$

Putting in our field gives

$$\begin{aligned} \Delta V &= - \int_A^B \frac{1}{4\pi\epsilon_0} \frac{2\lambda}{r} \hat{\mathbf{r}} \cdot (dr\hat{\mathbf{r}} + rd\theta\hat{\boldsymbol{\theta}} + dz\hat{\mathbf{z}}) \\ &= - \frac{2\lambda}{4\pi\epsilon_0} \int_A^B \frac{dr}{r} \end{aligned}$$

which we can integrate

$$\begin{aligned} \Delta V &= \left( -\frac{1}{2\pi} \frac{\lambda}{\epsilon_0} \ln r_B - \left( -\frac{1}{2\pi} \frac{\lambda}{\epsilon_0} \ln r_A \right) \right) \\ &= -\frac{1}{2\pi} \frac{\lambda}{\epsilon_0} (\ln r_B - \ln r_A) \end{aligned}$$

This example gives us a chance to think about our simple geometries and to consider when they are reasonable approximations to real charged objects. So long as neither  $r_A$  nor  $r_B$  are infinite, this result is reasonable. But remember what it looks like to move away from an infinite line of charge. No matter how far away we go, the line is still infinite. So we never get very far away. The terms

$$V_A = \frac{1}{2\pi} \frac{\lambda}{\epsilon_0} (\ln r_A)$$

or

$$V_B = \frac{1}{2\pi} \frac{\lambda}{\epsilon_o} (\ln r_B)$$

would look something like this

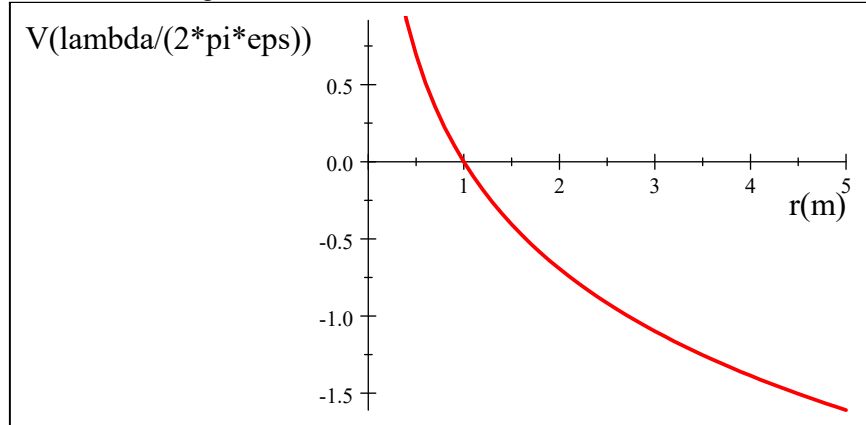

The curve is definitely not approaching zero as  $r$  gets large. No matter how far we get from an infinite line of charge, we really never get very far compared with its infinite length. So the potential is not going to zero!

Our solution is good only when  $r_A$  and  $r_B$  are much smaller than the length of the line. that is, when our simple geometry is a good representation for something that is real, in this case, a finite length wire. But for  $r_A, r_B \ll L$  this works.

We should also pause to think of the implications of this result for electronic equipment design. Our result means that adjacent wires in a cable or on a circuit board will feel a potential (in ME210 you called this a voltage) due to their neighbors—something we have to take into consideration in the design to ensure your equipment will work! This is one reason why we use shielded cables for delicate instruments, and for data lines, etc.

As a second example, let's tackle our friendly capacitor problem again. What is the potential difference as we cross the capacitor from point  $A$  to point  $B$ ? We already know the answer

$$\Delta V = Ed$$

But when we found this before, we assumed we knew the potential energy. This time let's practice using

$$\Delta V = - \int_A^B \vec{\mathbf{E}} \cdot d\vec{\mathbf{s}}$$



## Equipotential Surfaces

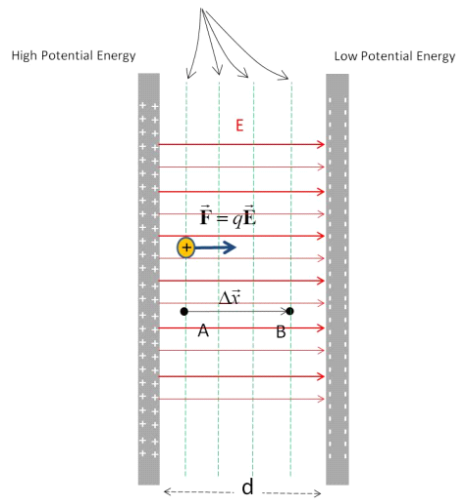

We know the field is

$$E = \frac{\eta}{\epsilon_0}$$

so

$$\begin{aligned} \Delta V &= - \int_A^B \vec{\mathbf{E}} \cdot d\vec{\mathbf{s}} \\ &= - \int_A^B \frac{\eta}{\epsilon_0} ds \cos \theta \end{aligned}$$

where  $\theta$  is the angle between the field direction and our  $d\vec{\mathbf{s}}$  direction. We could write

$$dx = ds \cos \theta$$

Then

$$\begin{aligned} \Delta V &= - \frac{\eta}{\epsilon_0} \int_A^B dx \\ &= - \frac{\eta}{\epsilon_0} (x_B - x_A) \\ &= - \frac{\eta}{\epsilon_0} \Delta x \end{aligned}$$

This is just

$$\Delta V = -E \Delta x$$

if we consider the negative side to be the zero potential, and we cross the entire capacitor, then

$$\begin{aligned} \Delta V &= -E (x_B - x_A) \\ &= -E (0 - d) \\ &= Ed \end{aligned}$$

as we expect. Note that we can now see how the positive result comes from our choice

of the zero voltage point.

## Sources of electric potential

Question 223.32.4

We know that the electric potential comes from the electric field. And if we think about it, we know where the electric field comes from, charge. But we have found that equal amounts of positive and negative charge produce no net field. So normal matter does not seem to have any net electric field because the protons and electrons create oppositely directed fields, with no net result.

But if we separate the positive and negative charges, we do get a field. This is the source of all electric fields that we see, and therefore all electric potentials are due to separated charge.

We have used charge separation devices already in our lectures. Rubbing a rubber rod with rabbit fur transfers the electrons from the fur to the rod. Some of the charges that were balanced in the fur are now separated. So there is an electric field that creates an electric force. Then there must be an electric potential, since the potential is just a manifestation of the field.

We have also used a van de Graaff generator. It is time to see how this works.

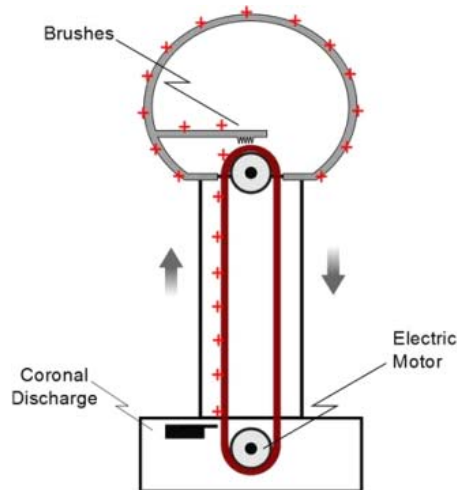

In the base of the van de Graaff, there is a small electrode. It is charged to a large voltage, and charge leaks off through the air to a rubber belt that is very close. The rubber belt is connected to a motor. The motor turns the belt. The extra charge is stuck

on the belt, since the belt is not a conductor. The charge is carried up to the top where there is a large round electrode. A conducting brush touches the rubber belt, and the charge is able to escape the belt through the conductor. The charge spreads over the whole spherical electrode surface.

The belt keeps providing charge. Of course the new charge is repelled by the charge already accumulated on the spherical electrode, so we must do work to keep the belt turning and the charge ascending to the ball at the top. This is a mechanical charge separation device. It can easily build potential differences between the spherical top and the surrounding environment (including you) of 30000 V.

Much larger versions of this device are used to accelerate sub atomic particles to very high speeds.

## Electrochemical separation of charge

Question 223.32.5

When you eat table salt, the NaCl ionic bond splits when exposed to polar water molecules, leaving a positively charged Na ion and a negatively charged Cl ion. This is very like the “bleeding” of charge from our charged balloons that we talked about earlier. The water molecules are polar, and the mostly positive hydrogens are attracted to the negatively charged Cl ions. This causes a sort of tug-o-war for the Cl ions. The positively charged Na ions pull with their coulomb force, and so do the positively charged hydrogens of the water molecules. If we have lots of water molecules, they win and the NaCl is broken apart. Water molecules are polar, but overall neutral. But now, with the Na and Cl ions, we have separated charge. We can make this charge flow, so we can get electric currents in our bodies. Our nervous system uses the positively charged Na ions to form tiny currents into and out of neurons as part of how nerve signaling works. Of course, NaCl is a pretty simple molecule. We could use more complex chemical reactions to separate charge.

## Batteries and emf

Most of us don't have a van de Graaff generator in our pockets. But most of us do have a charge separation device that we carry around with us. We call it a battery. But what does this battery do?

Somehow the battery supplies positive charge on one side and negative charge on the

other side. This is accomplished by doing work on the charges. A lead acid battery is often used in automobiles. The battery is made by suspending two lead plates in a solution of sulfuric acid and water.

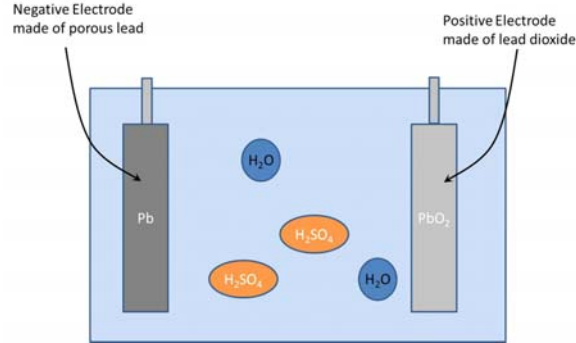

One plate is coated with lead dioxide. There is a chemical reaction at each plate. The sulfuric acid (H<sub>2</sub>SO<sub>4</sub>) splits into two H<sup>+</sup> ions and an SO<sub>4</sub><sup>-2</sup> ion.

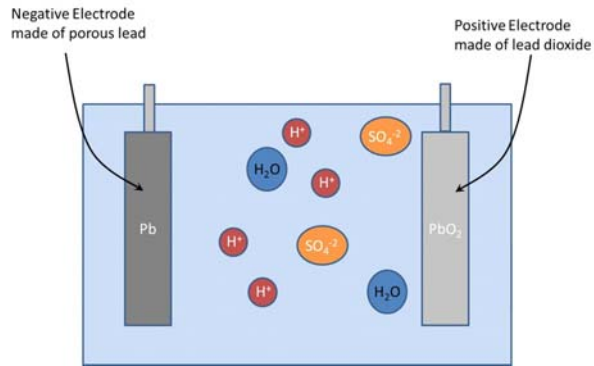

The plain lead plate reacts with the SO<sub>4</sub><sup>-2</sup> ions.

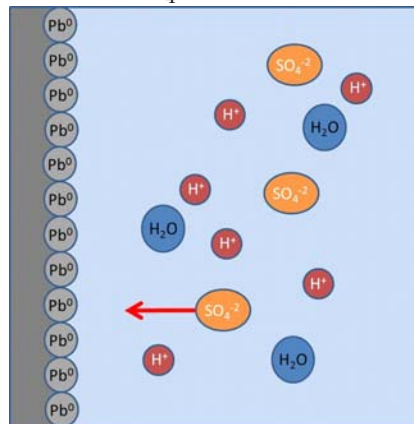

The overall reaction is

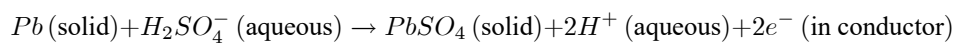

producing lead sulfate on the electrode, some hydrogen ions in solution and some extra electrons that are left in the metal plate.

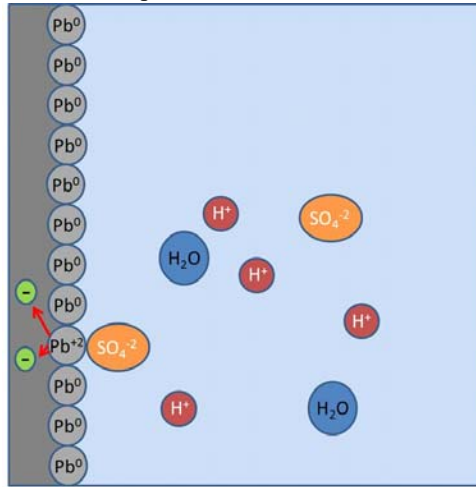

The coated plate's lead dioxide also reacts with the  $\text{SO}_4^{-2}$  ions and uses the hydrogen ions and the oxygen from the  $\text{PbO}_2$  coating.

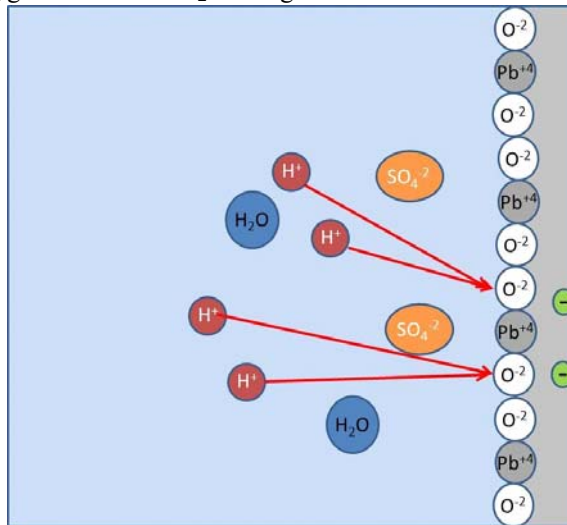

It also uses some electrons from the lead plate. The  $\text{PbO}_2$  splits apart and the  $\text{Pb}^{+4}$  combines with the  $\text{SO}_4^{-2}$  and the two electrons. The left over  $\text{O}_2$  combines with the hydrogens to form water. The reaction equation is

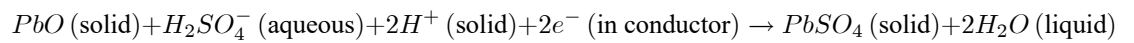

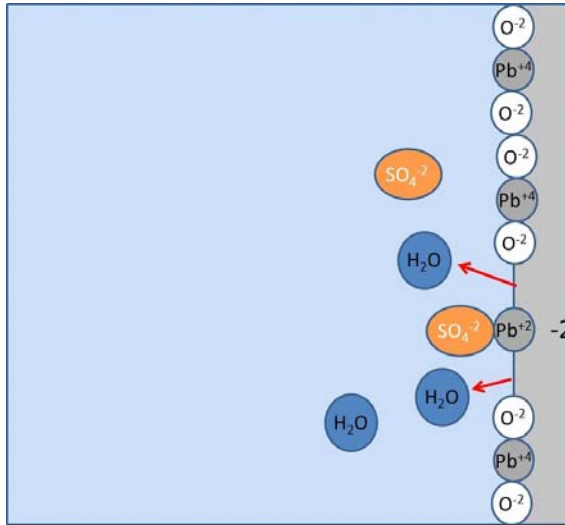

So one lead plate has two extra electrons, and one lacks two electrons. We have separated charge!

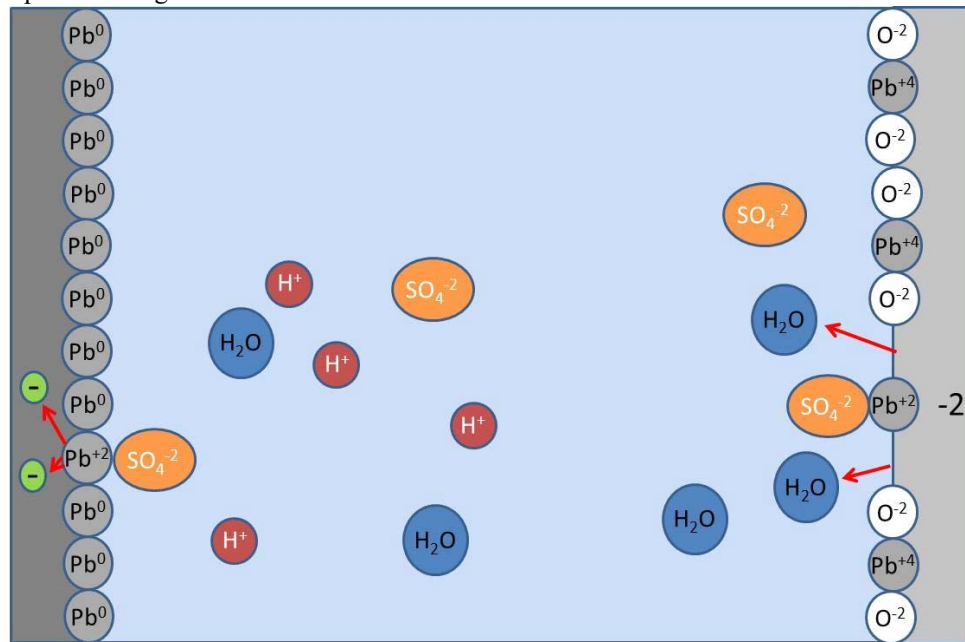

If we connect a wire between the plates, the extra electrons from one plate will move to the other plate, and we have formed a current (something we will discuss in detail later). Lead acid batteries are rechargeable. The recharging process places an electric potential across the two lead plates, and this drives the two chemical reactions backwards.

Now that we see that we can use chemistry to separate charge, let's think about what

this means for an electric circuit.

$$W_{chem} = \Delta U$$

That work is equivalent to an amount of potential energy, so we have a voltage. That voltage due to the separated charge is

$$\Delta V = \frac{W_{chem}}{q}$$

This is not a chemistry class, so we won't memorize the chemical process that does this. Instead, I would like to give a mechanical analogy.

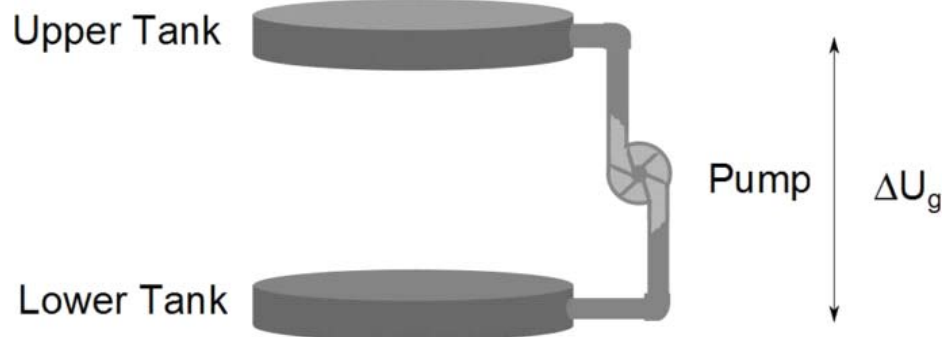

If we have water in a tank and we attach a pump to the tank, we can pump the water to a higher tank. The water would gain potential energy. This is essentially what a battery does for charge. A battery is sort of a “charge pump” that takes charge from a low potential to a high potential.

The water in the upper tank can now be put to work. It could, say, run a turbine.

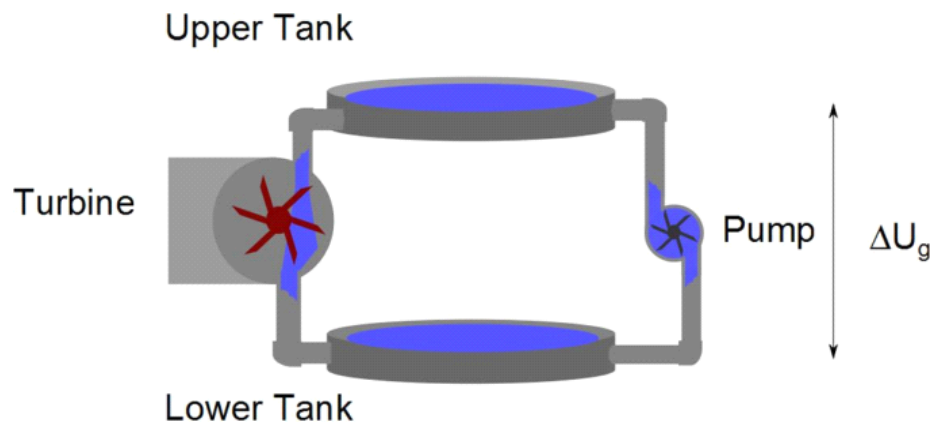

A battery can do the same. The battery “pumps” charge to the higher potential. That

charge can be put to work, say, lighting a light bulb.

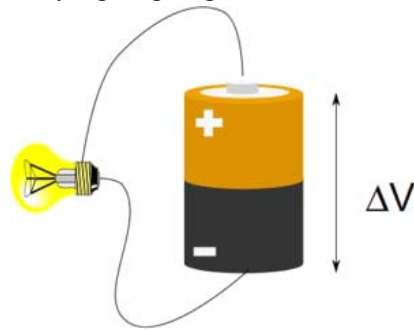

Of course, we could string pumps together to gain even more potential energy difference.

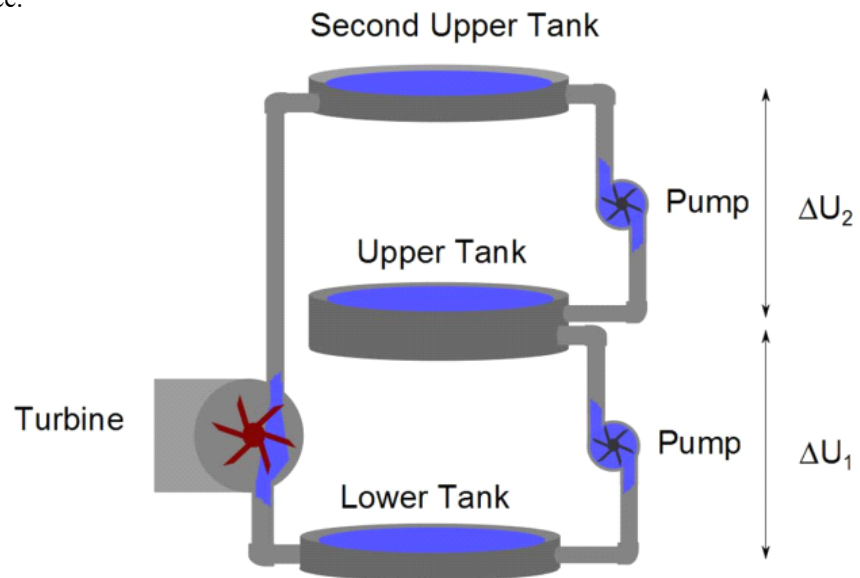

likewise we can string two batteries to get a larger electrical potential difference.



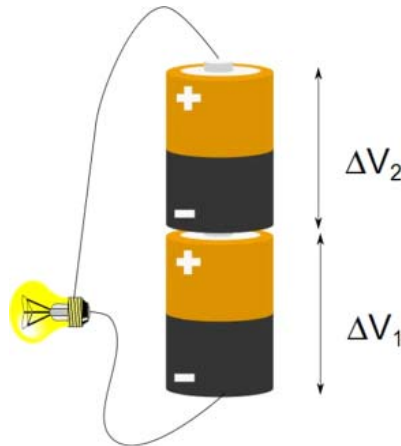

If we had more batteries, we would have more potential difference. Each battery “pumping” the charge up to a higher potential. Our analogy is not perfect, but it gives some insight into why stringing batteries together increases the voltage. Our clickers use three 1.5 V batteries for a total potential difference from the bottom of the first to the top of the last of

$$\Delta V = 3 \times 1.5 \text{ V} = 4.5 \text{ V}$$

If you have been introduced to Kirchhoff’s loop law, you may see this as familiar. Kerchhoff said that

$$\Delta V_{loop} = \sum_i \Delta V_i = 0$$

That is, if we go around a loop, we should end up at the same potential where we started. This would be true for our plumbing example. If we start at the lower tank, then travel through the pump to the upper tank, then through the turbine to the lower tank we have

$$\Delta U_{total} = \Delta U_{pump} + \Delta U_{turbine} = 0$$

we are at the same elevation, we lost all the potential energy we gained by being pumped up when we fell back down through the turbine.

Similarly, the battery pumps the charge up an amount  $\Delta V_{bat}$  and it “falls” down an amount  $\Delta V_{light}$  returning to where it started

$$\Delta V_{total} = \Delta V_{bat} + \Delta V_{light}$$

This is just conservation of energy. As we go around the loop we must neither create nor destroy energy. We can convert work into potential through the pump or battery, then we can create movement of water or charge and even useful work by letting the

charge or water “fall” back down to the initial state. The change in energy must be zero if there is no loss mechanism. Eventually we must allow some loss to occur, but for now we have ideal batteries and wires and lights, so energy is conserved.

We have a historic name for a charge pump like a battery. We call it an *emf*. This is pronounced “ee em eff,” that is, we say the letters. Emf used to stand for something, but that something has turned out to be a poor model for electric current, but the letters describing a charge pump persist. This is a little like Kentucky Fried Chicken changing it’s name to KFC because now they bake chicken (and no one wants to think about eating fried foods now days). The letters are the name.

Next lecture we will complete our task. In this lecture we discussed finding the potential if we know the field. Next lecture we will find out how to calculate the field if we know the potential.

## Basic Equations

# 14 Calculating fields from potentials

In our last lecture, we found that we could calculate the electric potential from the electric field. In this lecture we go the other way, calculating the field from the potential.

## Fundamental Concepts

- To find the field knowing the potential, we use  $\vec{\mathbf{E}} = -\left(\frac{d}{dx}\hat{i} + \frac{d}{dy}\hat{j} + \frac{d}{dz}\hat{k}\right)V$
- The gradient shows the direction of steepest change
- The potential of conductors in equilibrium

## Finding electric field from the potential

We did part-one of relating fields to potentials in the last lecture. Now it is time for part two, obtaining the electric field from a known potential. Starting with

$$\Delta V = - \int_A^B \vec{\mathbf{E}} \cdot d\vec{\mathbf{s}}$$

we realize that we should be able to write the integrand as a small bit of potential

$$\begin{aligned} dV &= -\vec{\mathbf{E}} \cdot d\vec{\mathbf{s}} \\ &= -E_s ds \end{aligned}$$

where  $E_s$  is the component of the electric field in the  $\hat{s}$  direction. We can rearrange this

$$E_s = -\frac{dV}{ds}$$

This tells us that the magnitude of our field is the change in electric potential. Of course,  $\vec{\mathbf{E}}$  is a vector and  $V$  is not. So the best we can do is to get the magnitude of the component in the  $\vec{\mathbf{s}}$  direction.

We can try this out on a geometry we know, say, a point charge along the  $x$ -axis

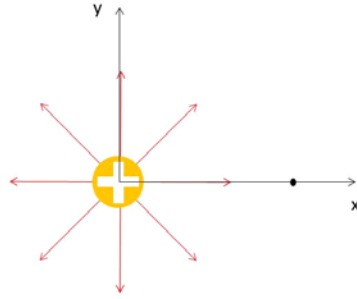

We know the potential will be

$$V = \frac{1}{4\pi\epsilon_0} \frac{qE}{x}$$

and we know the field is

$$\vec{E} = \frac{1}{4\pi\epsilon_0} \frac{qE}{r^2} \hat{r}$$

then we can try

$$\begin{aligned} E_s &= -\frac{dV}{dx} = -\frac{d}{dx} \frac{1}{4\pi\epsilon_0} \frac{qE}{x} \\ &= \frac{1}{4\pi\epsilon_0} \frac{qE}{x^2} \end{aligned}$$

Since  $r$  in the  $x$  direction is just  $x$ , this is just what we expected!

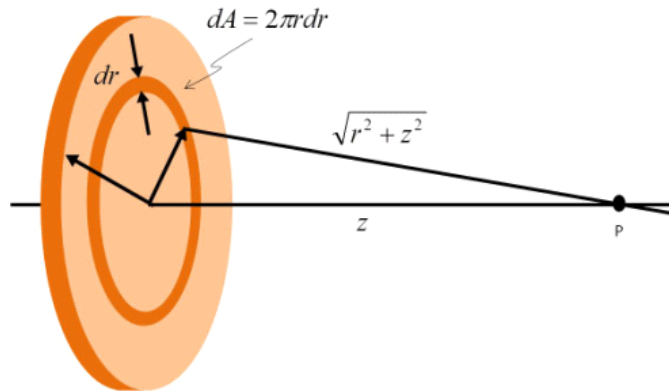

Let's try another. Let's find the electric field due to a disk of charge along the axis. We have done this problem before. We know the field should be

$$E_z = 2\pi k_e \eta \left( 1 - \frac{z}{\sqrt{a^2 + z^2}} \right) \tag{14.1}$$

and in the previous lectures we found the potential to be

$$V = \frac{\eta}{2\epsilon_0} \left( \sqrt{a^2 + z^2} - z \right) \tag{14.2}$$

Now can we find the electric field at  $P$  from  $V$ ? Let's start by finding the  $z$ -component

of the field,  $E_z$

$$E_z = -\frac{dV}{dz} \quad (14.3)$$

$$= -\frac{d}{dz} \left( \frac{\eta}{2\epsilon_o} \left( \sqrt{a^2 + z^2} - z \right) \right) \quad (14.4)$$

$$= -\frac{d}{dz} \frac{\eta}{2\epsilon_o} \sqrt{a^2 + z^2} - \frac{d}{dz} k_e \sigma 2\pi z \quad (14.5)$$

$$= -\frac{\eta}{2\epsilon_o} \frac{d}{dz} \sqrt{a^2 + z^2} + k_e \sigma 2\pi \quad (14.6)$$

$$= -\frac{\eta}{2\epsilon_o} \frac{z}{\sqrt{a^2 + z^2}} + 2\pi k_e \sigma \quad (14.7)$$

$$E_z = \frac{\eta}{2\epsilon_o} \left( 1 - \frac{z}{\sqrt{a^2 + z^2}} \right) \quad (14.8)$$

or

$$E_z = 2\pi k_e \eta \left( 1 - \frac{z}{\sqrt{a^2 + z^2}} \right) \quad (14.9)$$

But remember that this situation is highly symmetric. We can see by inspection that all the  $x$  and  $y$  components will all cancel out. So this is our field! And it is just what we found before.

We can graph these functions to compare them (what would you expect?). To do this we really need values, but instead, let's play a clever trick that some of you will see in advanced or older books. I am going to substitute in place of  $z$  the variable  $u = \frac{z}{a}$ . Then

$$\begin{aligned} V &= 2\pi\eta k_e \left( \sqrt{a^2 + z^2} - z \right) \\ &= 2\pi a \eta k_e \left( \sqrt{1 + \frac{z^2}{a^2}} - \frac{z}{a} \right) \\ &= 2\pi a \eta k_e \left( \sqrt{1 + u^2} - u \right) \end{aligned}$$

and

$$\begin{aligned}
 E_z &= 2\pi k_e \eta \left( 1 - \frac{z}{\sqrt{a^2 + z^2}} \right) \\
 &= 2\pi k_e \eta \left( 1 - \frac{z}{a\sqrt{1 + \frac{z^2}{a^2}}} \right) \\
 &= 2\pi k_e \eta \left( 1 - \frac{z}{a\sqrt{1 + \frac{z^2}{a^2}}} \right) \\
 &= 2\pi k_e \eta \left( 1 - \frac{\frac{z}{a}}{\sqrt{1 + \frac{z^2}{a^2}}} \right) \\
 &= 2\pi k_e \eta \left( 1 - \frac{u}{\sqrt{1 + u^2}} \right)
 \end{aligned} \tag{14.10}$$

Both my equation for  $V$  and for  $E_z$  now are in the form of a set of constants times a function of  $u$ .

$$\begin{aligned}
 V &= 2\pi a \eta k_e \left( \sqrt{1 + u^2} - u \right) \\
 &= 2\pi a \eta k_e f(u) \\
 E_z &= 2\pi k_e \eta \left( 1 - \frac{u}{\sqrt{1 + u^2}} \right) \\
 &= 2\pi k_e \eta g(u)
 \end{aligned} \tag{14.11}$$

If I plot  $V$  in units of  $2\pi a \sigma k_e$  (the constants out in front) I can see the shape of the curve. It is the function of  $f(u)$ . I can compare this to  $E_z$  in units of  $2\pi k_e \sigma$ . The shape of  $E_z$  will be  $g(u)$ . Of course we are plotting terms of  $u$ .

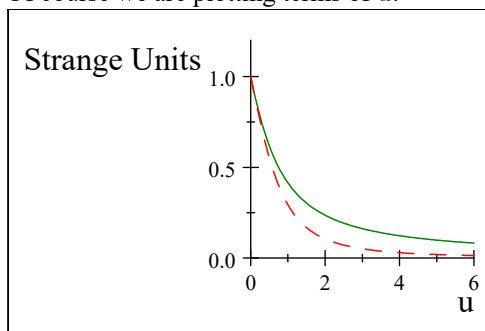

Now we can ask, is this reasonable? Does it look like the  $E$ -field (red dashed line) is the right shape for the derivative of the potential (solid green line)? It is also comforting to see that as  $u$  (a function of  $z$ ) gets larger the field falls off to zero and so does the potential as we would expect. When  $V$  (green solid curve) has a large slope,  $E_z$  is a

large number (positive because of the negative sign in the equation

$$E_s = -\frac{dV}{ds}$$

and when  $V$  is fairly flat,  $E_z$  is nearly zero. Our strategy for finding  $E$  from  $V$  seems to work.

## Geometry of field and potential

You should probably worry that so far our equation

$$E_s = -\frac{dV}{ds}$$

is only one dimensional. We know the electric field is a three dimensional vector field.

We may find situations where we need two or three dimensions. But this is easy to fix.

Our equation

$$E_s = -\frac{dV}{ds}$$

gives us the field magnitude along the  $\hat{s}$  direction. Let's choose this to be the  $\hat{x}$  direction. Then

$$E_x = -\frac{dV}{dx}$$

is the  $x$ -component of the electric field. Likewise

$$E_y = -\frac{dV}{dy}$$

$$E_z = -\frac{dV}{dz}$$

The total field will be the vector sum of it's components

$$\begin{aligned} \vec{E} &= E_x \hat{i} + E_y \hat{j} + E_z \hat{k} \\ &= -\frac{dV}{dx} \hat{i} - \frac{dV}{dy} \hat{j} - \frac{dV}{dz} \hat{k} \end{aligned}$$

Question 223.33.1

which we can cryptically write as

Question 223.33.2

$$\vec{E} = -\left(\frac{d}{dx} \hat{i} + \frac{d}{dy} \hat{j} + \frac{d}{dz} \hat{k}\right) V$$

The odd group of operations in the parenthesis is call a *gradient* and is written as

$$\vec{\nabla} = \left(\frac{d}{dx} \hat{i} + \frac{d}{dy} \hat{j} + \frac{d}{dz} \hat{k}\right)$$

using this we have

$$\vec{E} = -\vec{\nabla} V$$

which is how the relationship is stated in higher level electrodynamics books. But what does it mean?

The gradient is really kind of what it sounds like. If you go down a steep grade, you will notice you are going down hill and will notice if you are going down the steepest

part of the hill. The gradient finds the direction of steepest decent. That is, the direction where the potential changes fastest. This is like looking from the top of the hill and taking the steepest way down! Our relationship tells us that the electric field points in this steepest direction, and the minus sign tells us that the electric field points down hill away from a positive charge, never up hill (think of the acceleration due to gravity being negative). Let's see if this makes sense for our geometries that we know.

Stamp in a circle:  
mimic a blindfolded  
person swiveling on  
one foot and testing  
the slope with the  
other

Here is our capacitor. We see that indeed the field points from the high potential to the low potential. The steepest way "down the hill" is perpendicular to the equipotential lines.

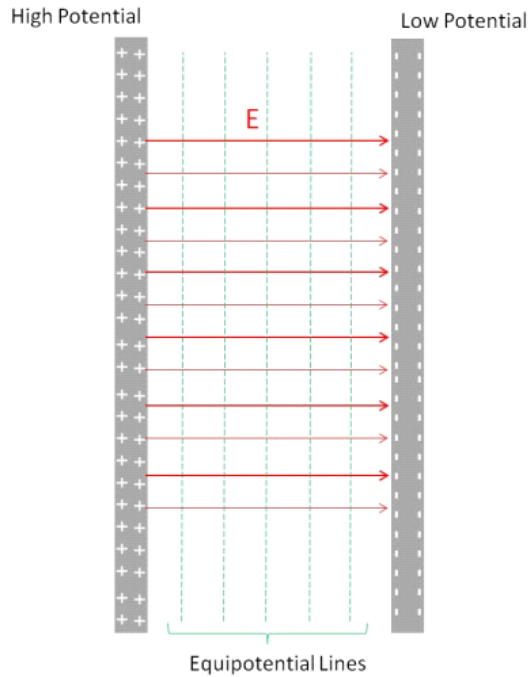

We also know the shape of the field for a dipole. The equipotential lines we have seen before.



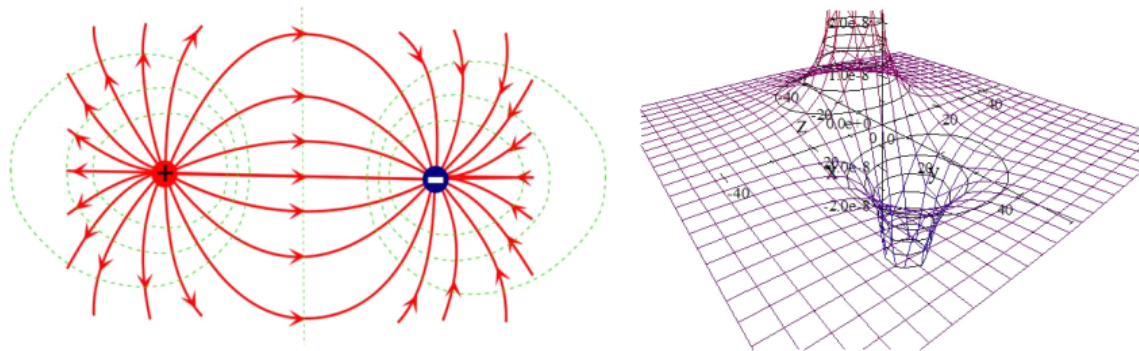

But now we can see that the field lines and equipotential lines are always perpendicular and the field points “down hill.” The meeting of the field and equipotential lines at right angles is not a surprise. Think again about our mountain

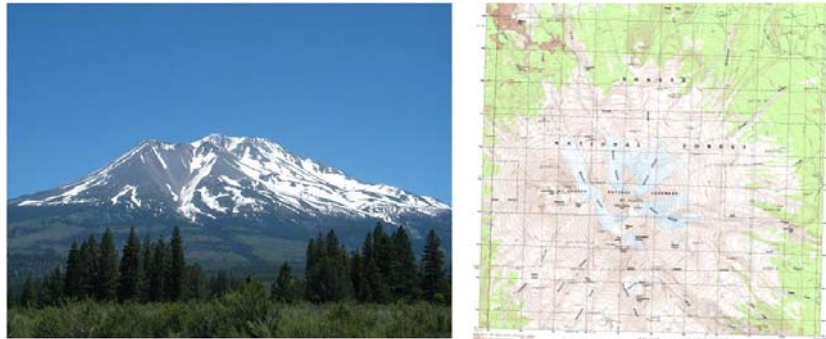

Map courtesy USGS, Picture is in the Public Domain.

The steepest path is always perpendicular to lines of equal potential energy.

We should try another example of finding the field from the gradient. Suppose we have a potential that varies as

$$V = 3x^2 + 2xy$$

I don't know what is making this potential, but let's suppose we have such a potential.

It would look like this.

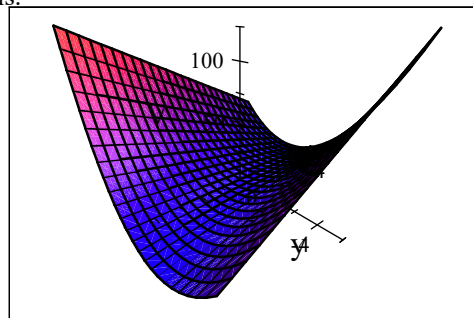

what is the electric field?

$$\vec{\mathbf{E}} = -\vec{\nabla}V$$

or

$$\vec{\mathbf{E}} = -\left(\frac{d}{dx}\hat{i} + \frac{d}{dy}\hat{j} + \frac{d}{dz}\hat{k}\right)V$$

so

$$\vec{\mathbf{E}} = -\left(\frac{d}{dx}\hat{i} + \frac{d}{dy}\hat{j} + \frac{d}{dz}\hat{k}\right)(3x^2 + 2xy)$$

$$\begin{aligned}\vec{\mathbf{E}} &= -\left(\hat{i}\frac{d}{dx}(3x^2 + 2xy) + \hat{j}\frac{d}{dy}(3x^2 + 2xy) + \hat{k}\frac{d}{dz}(3x^2 + 2xy)\right) \\ &= -\left(\hat{i}(6x + 2y) + \hat{j}\frac{d}{dy}(2xy) + 0\right)\end{aligned}$$

This example shows how to perform the operation, but it does not give much insight.

We have learned to work with our standard charge configurations, and this is really not one of them. So we don't have much intuitive feel for this electric field that we found.

To gain more insight, let's change back to one of our standard configurations. let's return to finding the point charge field from the point charge potential. The potential for a point charge is

$$V = \frac{1}{4\pi\epsilon_0} \frac{Q}{r}$$

And of course we know that the field is

$$E = \frac{1}{4\pi\epsilon_0} \frac{Q}{r^2} \hat{\mathbf{r}}$$

but we want to show this using

$$\vec{\mathbf{E}} = -\vec{\nabla}V$$

So

$$\begin{aligned}\vec{\mathbf{E}} &= -\left(\frac{d}{dx}\hat{i} + \frac{d}{dy}\hat{j} + \frac{d}{dz}\hat{k}\right)V \\ &= -\left(\frac{d}{dx}\hat{i} + \frac{d}{dy}\hat{j} + \frac{d}{dz}\hat{k}\right)\frac{1}{4\pi\epsilon_0} \frac{Q}{r}\end{aligned}$$

but we know in Cartesian coordinates

$$r = \sqrt{x^2 + y^2 + z^2}$$

so

$$\begin{aligned}
 \vec{\mathbf{E}} &= -\left(\frac{d}{dx}\hat{\mathbf{i}} + \frac{d}{dy}\hat{\mathbf{j}} + \frac{d}{dz}\hat{\mathbf{k}}\right) \frac{1}{4\pi\epsilon_o} \frac{Q_E}{\sqrt{x^2 + y^2 + z^2}} \\
 &= -\frac{Q_E}{4\pi\epsilon_o} \left(\frac{d}{dx}\hat{\mathbf{i}} + \frac{d}{dy}\hat{\mathbf{j}} + \frac{d}{dz}\hat{\mathbf{k}}\right) \frac{1}{\sqrt{x^2 + y^2 + z^2}} \\
 &= -\frac{Q_E}{4\pi\epsilon_o} \left(-\frac{x}{(x^2 + y^2 + z^2)^{\frac{3}{2}}}\hat{\mathbf{i}} - \frac{y}{(x^2 + y^2 + z^2)^{\frac{3}{2}}}\hat{\mathbf{j}} - \frac{z}{(x^2 + y^2 + z^2)^{\frac{3}{2}}}\hat{\mathbf{k}}\right) \\
 &= \frac{Q_E}{4\pi\epsilon_o} \frac{(x\hat{\mathbf{i}} + y\hat{\mathbf{j}} + z\hat{\mathbf{k}})}{(x^2 + y^2 + z^2)^{\frac{3}{2}}} \\
 &= \frac{Q_E}{4\pi\epsilon_o} \frac{(x\hat{\mathbf{i}} + y\hat{\mathbf{j}} + z\hat{\mathbf{k}})}{(x^2 + y^2 + z^2)\sqrt{(x^2 + y^2 + z^2)}} \\
 &= \frac{1}{4\pi\epsilon_o} \frac{Q_E}{r^2} \frac{(x\hat{\mathbf{i}} + y\hat{\mathbf{j}} + z\hat{\mathbf{k}})}{\sqrt{(x^2 + y^2 + z^2)}} \\
 &= \frac{1}{4\pi\epsilon_o} \frac{Q_E}{r^2} \hat{\mathbf{r}}
 \end{aligned}$$

but really, this is a bit of a mess, we don't want to do such a problem in rectangular coordinates. We could write  $\nabla$  in spherical coordinates (something we won't derive here, but you should have seen in M215 or M316).

$$\vec{\nabla} = \hat{\mathbf{r}} \frac{\partial}{\partial r} + \hat{\boldsymbol{\theta}} \frac{1}{r} \frac{\partial}{\partial \theta} + \hat{\boldsymbol{\phi}} \frac{1}{r \sin \theta} \frac{\partial}{\partial \phi}$$

Let's try this out on our point charge potential. We have

$$\begin{aligned}
 \vec{\mathbf{E}} &= -\left(\hat{\mathbf{r}} \frac{\partial}{\partial r} + \hat{\boldsymbol{\theta}} \frac{1}{r} \frac{\partial}{\partial \theta} + \hat{\boldsymbol{\phi}} \frac{1}{r \sin \theta} \frac{\partial}{\partial \phi}\right) V \\
 &= -\left(\hat{\mathbf{r}} \frac{\partial}{\partial r} + \hat{\boldsymbol{\theta}} \frac{1}{r} \frac{\partial}{\partial \theta} + \hat{\boldsymbol{\phi}} \frac{1}{r \sin \theta} \frac{\partial}{\partial \phi}\right) \frac{1}{4\pi\epsilon_o} \frac{Q_E}{r} \\
 &= -\frac{Q_E}{4\pi\epsilon_o} \left(-\frac{1}{r^2}\hat{\mathbf{r}} + 0 + 0\right) \\
 &= \frac{1}{4\pi\epsilon_o} \frac{Q_E}{r^2} \hat{\mathbf{r}}
 \end{aligned}$$

just as we expected. But this time the math was much easier. If we can, it is a good idea to match our expression for  $\vec{\nabla}$  to the geometry of the system. A good vector calculus book or a compendium of math functions will have various versions of  $\vec{\nabla}$  listed.

## Conductors in equilibrium again

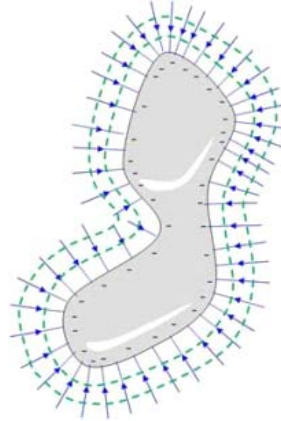

Question 223.33.3

We know that there is no field inside a conductor in electrostatic equilibrium, but we should ask what that means for the electric potential. To build circuits or electronic actuators, we will need to know this. Let's start again with

$$\Delta V = - \int_A^B \mathbf{E} \cdot d\mathbf{s} \quad (14.12)$$

and since the field  $E = 0$  inside the conductor, then inside

$$\Delta V_{inside} = 0 \quad (14.13)$$

On the surface we see that there is a potential, since there is a field. If we take our spherical case,

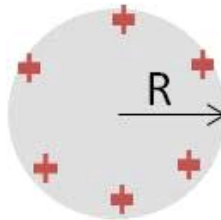

and observe the potential as we go away from the center, we expect the potential to be constant up to the surface. Then as we reach the surface, we know from Gauss' law that the field will be

$$E = \frac{1}{4\pi\epsilon_0} \frac{Q_E}{r^2}$$

like a point charge, so the potential at the surface must be

$$V = \frac{1}{4\pi\epsilon_0} \frac{Q_E}{R}$$

where  $r = R$ , the radius of our sphere. As we move into the sphere from the surface, the potential must not change. The interior will have the potential

$$V_{inside} = \frac{1}{4\pi\epsilon_0} \frac{Q_E}{R} \quad (14.14)$$

Outside, of course, the potential will drop like the potential due to a point charge. We expect

$$V = \frac{1}{4\pi\epsilon_0} \frac{QE}{r} \tag{14.15}$$

For a sphere of radius  $R = 0.5 \text{ m}$  carrying a charge of  $0.000002 \text{ C}$  (about what our van de Graaff holds) we would have the situation graphed in the following figure:

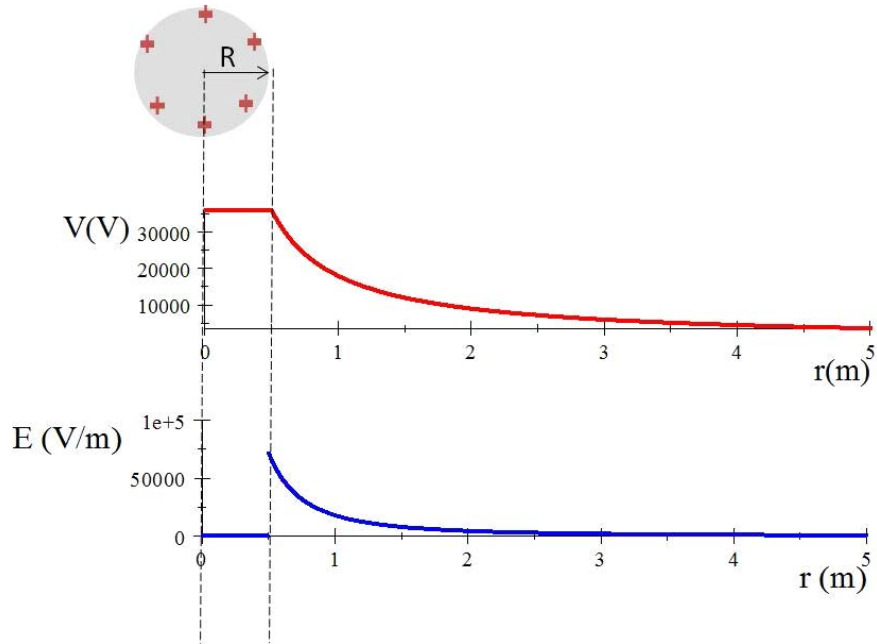

This is an important point. For a conductor, the electric potential everywhere inside the conductive material is exactly the same once we reach equilibrium. This is just what we want for capacitors or electrodes or electrical contacts in circuits.

### Non spherical conductors

The field is stronger where the field lines are closer together. One way to describe this is to use a radii of curvature. That is, suppose we try to fit a small circle into a bump on the surface of a conductor.

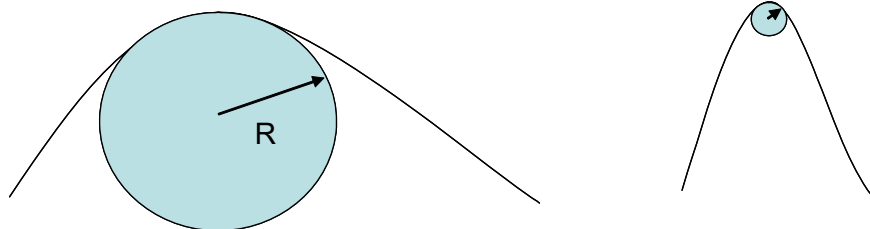

In the figure there are two bumps shown with circles fit into them. The bump on the right has a much smaller radius circle than the one on the left. The radius of the circle that fits into the bump is the radius of curvature of the bump. From what we have said, the bump on the right will have a much stronger field strength near it than the bump on the left.

Where there is a lot of charge on a conductor, and the field is very high, electrons from random ionizations of air molecules near the conductor are accelerated away from the conductor. These electrons hit other atoms, ionizing them as well. We get a small avalanche of electrons. Eventually the electrons recombine with ionized atoms, producing an eerie glow. This is called *corona discharge*. It can be used to find faults in high tension wires and other high voltage situations.

Coronal Discharge  
Clips

### Cavities in conductors

Suppose we have a hollow conductor with no charges in the cavity. What is the field? We know from using Gauss' law what the answer should be, but let's do this using potentials.

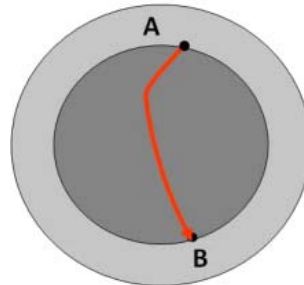

All the parts of the conductor will be at the same potential. So let's take two points,  $A$  and  $B$ , and compute

$$V_A - V_B = - \int_A^B \mathbf{E} \cdot d\mathbf{s}$$

We know that  $V_A - V_B = 0$  because  $V_A$  must be the same as  $V_B$ . So for every path,  $s$ , we must have

$$- \int_A^B \mathbf{E} \cdot d\mathbf{s} = 0$$

We can easily conclude that  $E$  must equal zero.

So as long as there are no charges inside the cavity, the cavity is a net field free zone.

It is often much easier to find the potential, and from the potential, find the field. Much of the study of electrodynamics uses this approach. This is because it is more straight-forward to differentiate than it is to integrate. Some of you may use massive computational programs to predict electric fields. They often use differential equations in the potential to find the field rather than integral equations to find the field directly.

## Basic Equations





# 15 Capacitance

## Fundamental Concepts

- The charge on a capacitor is proportional to the potential difference  $Q = C\Delta V$
- The constant of proportionality is called the capacitance and for a parallel plate capacitor, it is given by  $C = \frac{A}{d}\epsilon_o$
- In parallel capacitors capacitances add  $C_{eq} = C_1 + C_2$
- In series capacitors capacitances combine as  $\frac{1}{C_{tot}} = \frac{1}{C_1} + \frac{1}{C_2}$

## Capacitance and capacitors

Consider the following design for a pump-tank system.

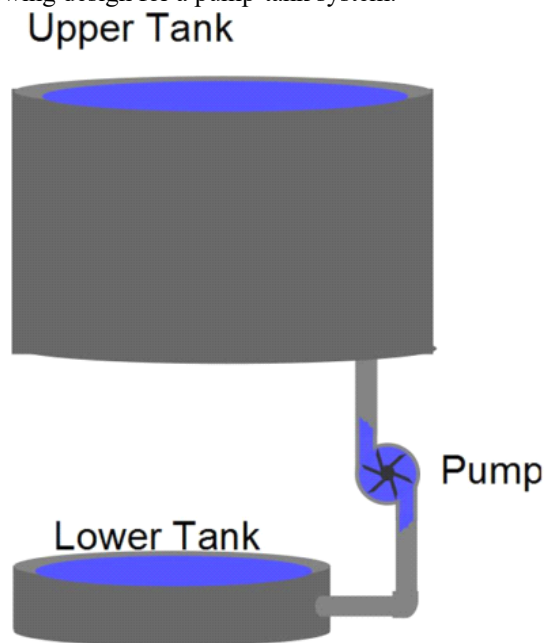

This is may not be an optimal design. At first there is no problem, water flows into the upper tank just fine. But once the upper tank begins to fill, the water already in the

upper tank will make it harder to pump in more water. As the tank fills, the pressure at the bottom increases, and it takes more work for the pump to overcome the increasing pressure.

Something analogous happens when a capacitor is connected to a battery.



At first the charge is free to flow to the plates, but as the charge builds, it takes more work to bring on successive charges.

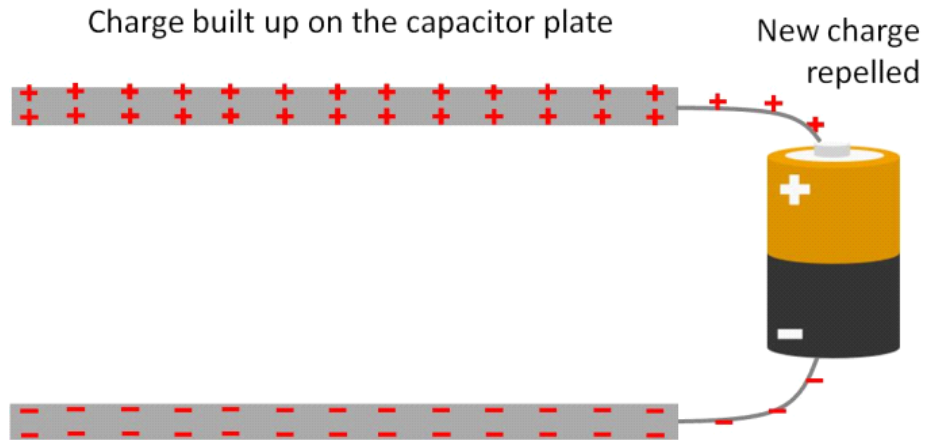

The charges repel each other, so the charge already on a capacitor plate repels the new charge arriving from the battery. The repelling force gets larger until finally the force repelling the charge balances the force driving the charge from the battery and the charge stops flowing onto the capacitor.

A capacitor is made from two plates. For us, let's assume they are semi-infinite sheets of charge. Of course this is not exactly true, but it is not too wrong near the center of the plates. And we know quite a lot about semi-infinite sheets of charge because they

are one of our standard charge configurations. We know the field for each sheet is

$$E = \frac{\eta}{2\epsilon_o}$$

and that for two sheets, one with  $+\eta$  and one with  $-\eta$  the field in between will be

$$E = \frac{\eta}{\epsilon_o}$$

We also know the potential difference between the two plates is just

$$\Delta V = Ed$$

where  $E$  is our electric field and  $d$  is the capacitor spacing.

We can guess that we will build up charge until the potential energy difference of the capacitor is equal to the potential energy difference of the battery

$$\Delta V_{\text{capacitor}} = \Delta V_{\text{battery}}$$

because at that point the forces causing the potential energy will be equal.

We can write our electric field between the two plates as

$$E = \frac{\eta}{\epsilon_o} = \frac{Q}{A\epsilon_o}$$

so

$$\Delta V = \frac{d}{A\epsilon_o}Q$$

Then the potential difference is directly proportional to the charge. I want to switch this around, and solve for the amount of charge.

$$Q = \left( \frac{A\epsilon_o}{d} \right) \Delta V$$

Since all the terms in the parenthesis are constants, we could replace them with a constant,  $C$ .

$$Q = C\Delta V \quad (15.1)$$

where

$$C = \frac{A}{d}\epsilon_o \quad (15.2)$$

is a constant that depends on the geometry and construction of the plates. This equation tells us that if we build two different sets of plates, say, one circular and one triangular, and we give them the same potential difference (say, connect them both to 12 V batteries) then, if both have the same construction constant  $C$ , they will carry the same charge even though their size and shape are different. We can reduce the burden of calculation of how much charge a capacitor can hold but asking the person who manufactured it to calculate the construction constant and mark the value on the outside of the capacitor. Different capacitors may be constructed differently (different  $A$  or  $d$  values) but so long as the construction constant,  $C$ , is the same, the charge amount for a given voltage will be the same.

The electronics field gives this construction constant a name, *capacitance*.

$$C = \frac{Q}{\Delta V} \quad (15.3)$$

The capacitance will have units of  $C/V$  but we give this a name all it's own, the *Farad* (F). A Farad is a very large capacitance. Many capacitors in electronic devices are measured in microfarads.

Question 223.34.2

Question 223.34.3

Question 223.34.4

## Capacitors and sources of potential

Consider what happens when we connect our two parallel plates to the terminals of a battery. Assuming the plates are initially uncharged, charge flows from the battery through the conducting wires and onto the plates. Recall that for a metal, the entire surface will be at the same potential under electrostatic conditions. The charge carriers supplied by the battery will try to achieve electrostatic equilibrium, so we expect the plate that is connected to the positive terminal of the battery to eventually be at the same potential as the positive battery terminal. Likewise for the negative terminal and the plate connected to it.

We can even use our capacitor as a source of electrical power. A camera flash uses capacitors to make the burst of light that illuminates the subject of your photo. In ME210 you should have studied RC circuits, so you will understand that the battery is used to charge the capacitor and then a switch is thrown to allow the charge to quickly leave through a different circuit, making the flash.



Camera flash unit (Public Domain image by Julio)

## Single conductor capacitance

Physicists can't leave a good thing alone. We often calculate the capacitance of a single

conductor! If the geometry is simple we can easily do this. It is not immediately obvious that a single conductor should even have a capacitance, so it might be a problem if you forget this in a design problem for an unusual device.

As an example, let's take a sphere. We will assume there is a spherical conduction shell that is infinitely far away. This configuration gives exactly the same field lines that the charged sphere gives on its own, but the mental picture is helpful. The imaginary shell will give  $V = 0$  (we set our zero potential at  $r = \infty$ ). The potential of the little sphere we know must be just like the potential of a point charge if we are outside of the sphere

$$V = k_e \frac{Q}{r}$$

for  $r = R$ , the radius of our little sphere. Then

$$\Delta V = k_e \frac{Q}{R} - 0 = k_e \frac{Q}{R}$$

so

$$C = \frac{Q}{\Delta V} = \frac{Q}{k_e \frac{Q}{R}} = \frac{R}{k_e} = 4\pi\epsilon_o R \tag{15.4}$$

This is the capacitance of a single sphere. Note that  $C$  only depends on geometry! not on  $Q$ , just as we would expect.

But why would we care? If you have taken ME210 you know about RC circuits. This says that even if we just connect a ball to, say, the positive terminal of a battery, that there will be some capacitance. This capacitance will limit the flow of charge to the ball. So it will take time to charge even a single conductor. This is always true when a device is initially connected to a power source. Often we can ignore such "transient" effects because the charging times are still small. But in special cases, this may not be possible because the changing voltage or charge could damage sensitive equipment. So although this is rarely a problem, it is good to keep in the back of our minds.

## Capacitance of two parallel plates

The capacitance of single conductors is profound, but more useful to us in understanding common electronic components is the parallel plate capacitor. We found that for parallel plates we also had only geometry factors in the capacitance. Of course, there are other shapes possible. Let's see if we can reason out how the capacitance depends on the geometry.

### Plate area

Since the charge will tend to separate to the surface of a conductor, we might expect

that if the surface area increases, the amount of charge that the capacitor can hold might increase as well. We see this in our equation for the parallel plate capacitor.

$$C = \frac{A}{d} \epsilon_o$$

### Plate separation

We also see that it matters how far apart the plates are placed. The greater the distance, the less the capacitance. This makes some sense. If the plates are farther apart, the Coulomb force is weaker, and less charge can be held in the capacitor, because the force attracting the charges (the force between the charges on the opposite plates) is weaker.

### Capacitance of a cylindrical capacitor

We should try some harder geometries. A cylindrical capacitor is a good case to start with



(you will do a sphere in the homework problems). We want to find the capacitance of the cylindrical capacitor. Our strategy will be to find the voltage difference for the capacitor and the amount of charge on the capacitor, and then divide to find  $C$ .

$$C = \frac{Q}{\Delta V}$$

Let's begin with our equation relating potential change to field.

$$V_b - V_a = - \int_a^b \vec{\mathbf{E}} \cdot d\vec{\mathbf{s}} \quad (15.5)$$

Let's assume that there is a linear charge density,  $\lambda$ , along the cylinder with the center

positive and the outside negative. Then

$$\Phi_E = \oint \vec{E} \cdot d\vec{A} \quad (15.6)$$

where I will choose a Gaussian surface that is cylindrical around the central conductor.

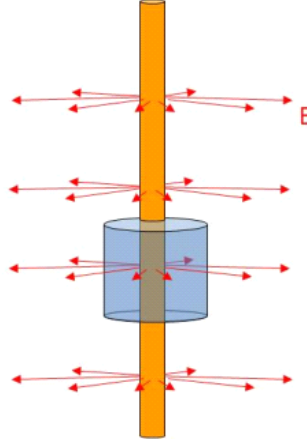

This is nice, since the field will be radially out from the conductor (ignoring the end effects) and so no field will pass through the end caps of the Gaussian surface ( $\vec{E} \cdot d\vec{A} = 0$  on the end caps). Moreover, the field strikes the surface at right angles ( $\vec{E} \cdot d\vec{A} = E dA$  on the side of the cylinder), and will have the same magnitude all the way around so

$$\begin{aligned} \Phi_E &= E \oint dA \\ &= EA \end{aligned}$$

Now we know from Gauss' law that

$$\Phi_E = \frac{Q_{in}}{\epsilon_o}$$

where

$$Q_{in} = \lambda h$$

and where  $h$  is the height of our Gaussian surface, so

$$\begin{aligned} \Phi_E &= \frac{\lambda h}{\epsilon_o} = E 2\pi r h \\ \frac{\lambda}{2\pi r \epsilon_o} &= E \end{aligned}$$

Now, knowing our field, and taking a radial path from  $a$  to  $b$ , we can take

$$\begin{aligned} V_b - V_a &= - \int_a^b \frac{\lambda}{2\pi r \epsilon_o} dr \\ &= - \frac{\lambda}{2\pi \epsilon_o} \int_a^b \frac{1}{r} dr \\ &= - \frac{\lambda}{2\pi \epsilon_o} \ln \left( \frac{b}{a} \right) \end{aligned}$$

Using this, we can find the capacitance. We have a negative value for  $\Delta V$ , but this is just due to our choice of making the center of the concentric cylinders positive and the outside negative. We chose the zero point on the positive center. The amount of potential change going from  $a$  to  $b$  is just  $|\Delta V|$ . Then in finding the capacitance using

$$Q = C\Delta V$$

we want just the value of  $\Delta V$  so we will plug in the absolute value of our result.

$$|\Delta V| = \frac{\lambda}{2\pi\epsilon_0} \ln\left(\frac{b}{a}\right)$$

Then, solving for  $C$  gives

$$\begin{aligned} C &= \frac{Q}{\Delta V} \\ &= \frac{Q}{\frac{\lambda}{2\pi\epsilon_0} \ln\left(\frac{b}{a}\right)} \\ &= \frac{Q}{\frac{Q}{2\pi h\epsilon_0} \ln\left(\frac{b}{a}\right)} \\ &= \frac{2\pi h\epsilon_0}{\ln\left(\frac{b}{a}\right)} \end{aligned}$$

Wow! That was fun! But more importantly, this is a coaxial cable geometry, and we can see that coaxial cable will have some capacitance and that that capacitance will depend on the geometry of the cable including its length and width. This capacitance can affect signals sent through the cable. If you have taken ME210 and have considered RC circuits, you can see why.

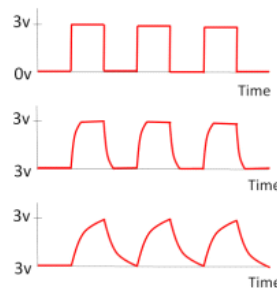

Increasing amounts of distortion in a signal due to increasing cable capacitance. The nice square pulses that represent digital data will be distorted, and in extreme cases, undetectable. When designing data lines, this capacitance of the cable must be taken into account.

## Combinations of Capacitors

Question 223.34.5

We don't want to have to do long calculations to combine capacitors that we buy



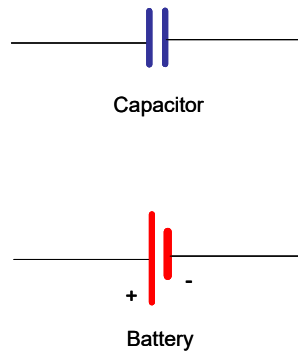
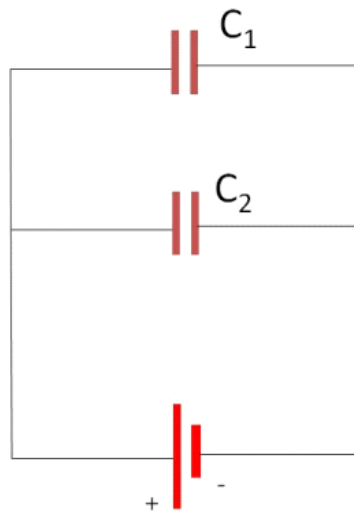

Figure 15.6.

from an electronics store. It would be convenient to come up with a way to combine capacitors using a simple rule.

We need a simple way to write capacitors in our homework problem drawings, here are the usual symbols for capacitor and battery. Using these symbols, let's consider two capacitors as shown below.



Remember that a conductor will be at the same potential over all of its surface. If we connect the capacitors as shown then all of the left half of this diagram will be at the positive potential of the battery terminal. Likewise, the right side will all be at the same potential. It is like we increased the area of the capacitor  $C_1$  by adding in the area of

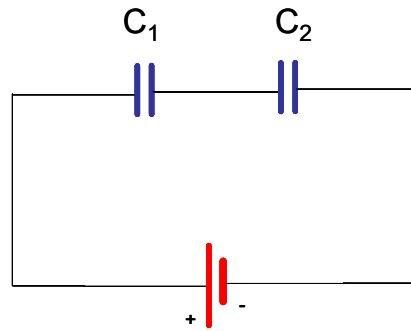

Figure 15.7.

capacitor  $C_2$ .

$$C = \frac{A_1 + A_2}{d} \epsilon_o = \frac{A_1}{d} \epsilon_o + \frac{A_2}{d} \epsilon_o$$

So we may write a combined capacitance for this set up of

$$C_{eq} = C_1 + C_2 \quad (15.7)$$

We call this set up a *parallel* circuit. This means that each of the capacitors are hooked directly to the terminals of the battery.

But suppose we hook up the capacitors as in the next drawing. Now we expect the left hand side of  $C_1$  to be at the positive potential of the positive terminal of the battery. We expect the right side of  $C_2$  to be at the same potential as the negative side of the battery. What happens in the middle?

We can see that we will have negative charge on the right hand plate of  $C_2$  and positive charge on the left plate of  $C_1$ . This must cause there to be a positive charge on the right plate of  $C_1$  and a negative charge on the left plate of  $C_2$ . Moreover, all the charges will have the same magnitude. That means each of the plates will have a potential difference

$$\Delta V_1 = \frac{Q}{C_1}$$

and

$$\Delta V_2 = \frac{Q}{C_2}$$

But the total potential difference is  $\Delta V$  of the battery, then

$$\Delta V = \Delta V_1 + \Delta V_2$$

We can again define an equivalent capacitance.

$$\Delta V = \frac{Q}{C_{tot}}$$

then

$$\begin{aligned}\Delta V &= \Delta V_1 + \Delta V_2 \\ \frac{Q}{C_{tot}} &= \frac{Q}{C_1} + \frac{Q}{C_2}\end{aligned}$$

The  $Q$ s are all the same. So

$$\frac{1}{C_{tot}} = \frac{1}{C_1} + \frac{1}{C_2} \quad (15.8)$$

We call this type of set up a *series circuit*.

Now after all this you might ask yourself how to know the capacitance of the parts you buy to build things. They are designed by engineers and tested at the factory, and the capacitance is usually printed on the side of the device. You can, of course, devise a test circuit based on what we have learned that could test the capacitance.

## Basic Equations



# 16 Dielectrics and Current

## Fundamental Concepts

- Dielectrics and capacitors
- Microscopic nature of electric current
- Current direction is defined as the direction positive charges would go, regardless of the actual sign of the charge.
- In a capacitor, the stored energy is  $W = \frac{1}{2}C\Delta V^2$
- The energy density in the electric field is  $u = \frac{1}{2}\epsilon_0 E^2$

## Energy stored in a capacitor

We have convinced ourselves that  $\Delta V$  is the change in potential energy per unit charge, so when a capacitor is charged, and the wires connecting it to the battery are removed, is there potential energy “stored” in the capacitor? The answer is yes, and we can see it by considering what would happen if we connected a wire (no battery) between the two plates. Charge would rush from one plate to the other. This is like storing a tank of water on a hill. If we connect a pipe from the tank at the top of the hill to a tank at the bottom of the hill, the water will rush through the pipe to the lower tank.

BE CAREFUL, you are enough of a conductor that by touching different ends of a capacitor you could create a serious current through your body. The capacitors in computer monitors or TV sets can store enough charge to kill you!

But how do we know how much energy is there? Clearly it must be related to the amount of energy it takes to move the charge onto the plates. By analogy, the energy stored in the water was the minimum amount of energy it took to pump the water to the upper tank ( $mgh$ ). It is the minimum, because our pipes might have some resistance, and then we would have to include more work to overcome the resistance.

But for a capacitor it is a little bit more tricky. When the capacitor is not charged, it

takes no work (or very little) to move charge from one plate to the other. But once there is a charge there is an electric field between the plates (think of my poorly designed water storage system from the beginning of last lecture). This creates a potential difference. And we must fight against this potential difference to add more charge. This is sort of like transferring rocks up a hill. The more rocks that we carry, the higher the hill gets, and the more work it takes to bring up more rocks.

From our formula

$$W = q(V_B - V_A)$$

we can see that if we have just a small amount of charge,  $\Delta Q$ , we will have a small amount of work

$$\Delta W = \Delta Q \Delta V$$

to move it onto the capacitor. Note! here  $\Delta Q$  is a small amount of charge, and  $\Delta V$  is  $V_f - V_i$ . We have used  $\Delta$  in two different ways in the same equation. If we start with no charge, then go in small  $\Delta Q$  steps, we would see a potential rise as shown in the graph below.

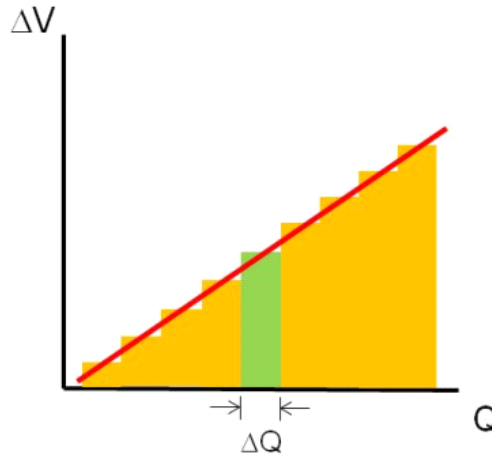

The quantity  $\Delta Q \Delta V$  is the area of the shaded (e.g. green) rectangle. So  $\Delta W$ , the work it took to add  $\Delta Q$  to the capacitor, is given by the area of a rectangle under a stair-step on our graph. The stair-shape comes from the fact that every time we deliver a  $\Delta Q$  package of charge to the capacitor, it makes the potential a little higher. It takes more work to bring in the next package of charge,  $\Delta Q$ .

From our basic equation

$$Q = C \Delta V$$

we can write, for our small bit of charge,  $\Delta Q$

$$\Delta V = \frac{\Delta Q}{C}$$

As  $\Delta Q$  gets small we can go to a continuous charge model

$$\Delta W = \Delta Q \Delta V$$

We can replace the small unit of charge  $\Delta Q$  with a continuous variable  $dq$  to obtain

$$dW = dq(\Delta V)$$

Recall that

$$\Delta V = \frac{q}{C}$$

so we can write  $dW$  as

$$dW = dq \left( \frac{q}{C} \right)$$

$$dW = \frac{1}{C} q dq$$

Of course, we will integrate this

$$\begin{aligned} W &= \int_0^Q \frac{1}{C} q dq \\ W &= \frac{1}{C} \int_0^Q q dq \\ &= \frac{Q^2}{2C} \end{aligned} \tag{16.1}$$

or sometimes using

$$Q = C \Delta V$$

this is written as

$$W = \frac{1}{2} C \Delta V^2 \tag{16.2}$$

There is a limit to how much energy we can store. That is because even air can conduct charge if the potential difference is high enough. We call this air conduction a spark or coronal discharge. At some point charge jumps from one plate to another through the air in between. If the potential difference is very high, the Coulomb force between the charges on opposite plates will force charge to leave one plate and jump to the other even if there is no air!

Question 223.34.6

Question 223.34.7

## Field storage

We usually consider the energy stored in the capacitor to be stored in the electric field. The field is proportional to the amount of charge and related to the potential energy, so this seems reasonable. Let's find the potential energy stored in the field in the capacitor.

Recall for an ideal parallel plate capacitor

$$\Delta V = Ed$$

and

$$C = \epsilon_o \frac{A}{d}$$

We assume that energy provided by the work to move the charges on the capacitor is all stored as potential energy, so

$$U_{stored} = \frac{1}{2} C \Delta V^2 \quad (16.3)$$

then

$$\begin{aligned} U_{stored} &= \frac{1}{2} \left( \epsilon_o \frac{A}{d} \right) (Ed)^2 \\ &= \frac{1}{2} \epsilon_o A d E^2 \end{aligned}$$

We often define an energy density

$$u = \frac{U_{stored}}{V}$$

In this case the volume  $V$  is just  $Ad$  so

$$u = \frac{1}{2} \epsilon_o E^2 \quad (16.4)$$

This is the density of energy in the electric field. It turns out that this is a general formula (not just true for ideal parallel plate capacitors).

This is a step toward our goal of showing that electric fields are a physically real thing. They can store energy, so they must be a real thing.

## Dielectrics and capacitors

Question 223.35.1

We should ask ourselves a question about our capacitors, does it matter that there is air in between the plates? For making capacitors, it might be convenient to coat two sides of a plastic block with metal and solder wires to the coated sides. Does the plastic have an effect?

Plastic is an insulator, and another name for “insulator” is *dielectric*. If we perform the experiment, we will find that when a dielectric is placed in the plates, the potential difference decreases!



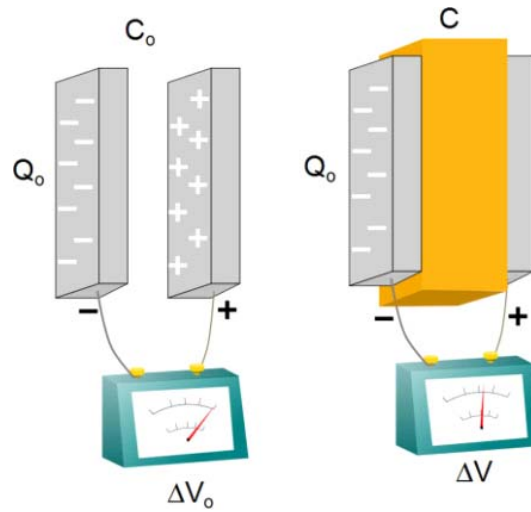

We are lucky, though, from experimentation we have found that it seems to decrease in a nice, linear way. We can write this as

$$\Delta V = \frac{\Delta V_0}{\kappa} \quad (16.5)$$

where  $\kappa$  is a constant that depends on what material we choose as our dielectric<sup>13</sup>. But what is happening?

The plates of the capacitor are becoming charged. These charges will polarize the material in the middle.

<sup>13</sup> This symbol  $\kappa$ , is the greek letter “kappa.”

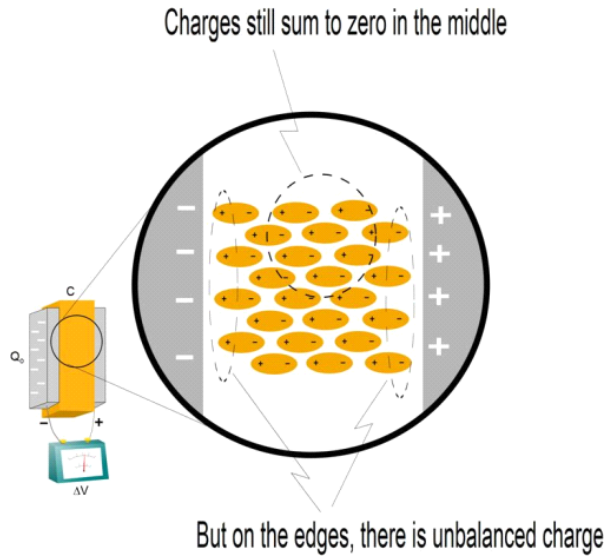

Question 223.35.2

Unbalanced Handedness Demo, Stick out your hands, one side of room has extra left hands, one side extra right hands

Question 223.35.3

Notice how the polarized molecules or atoms still have a net zero charge in the middle, but on the ends, there is a net charge. It is like we have oppositely charged plates next to our capacitor plates. That reduces the net charge seen by the capacitor, and so the potential difference is less. There is effectively less separated charge.

But since our capacitor is not connected to a battery or any other electrical device, the amount of actual charge on the capacitor plates can't have changed, so if  $\Delta V$  changed, but  $Q$  did not, then since

$$Q = C\Delta V$$

we suspect the material properties part, or the capacitance must have changed.

$$C = \frac{Q_o}{\Delta V} = \frac{Q_o}{\frac{\Delta V_o}{\kappa}} = \frac{\kappa Q_o}{\Delta V_o}$$

but this is just

$$C = \kappa C_o \tag{16.6}$$

For a parallel plate capacitor, we have

$$C = \kappa \epsilon_o \frac{A}{d} \tag{16.7}$$

So where do you find values for  $\kappa$ ? For this class, we will look them up in the tables in

books or at manufacturer’s web sites. Here are a few values for our use.

Material	$\kappa$	Material	$\kappa$
Vacuum	1.00000	Paper	3.7
Dry Air	1.0006	Waxed Paper	3.5
Fused quartz	3.78	Polystyrene	2.56
Pyrex glass	4.7 – 5.6	PVC	3.4
Mylar	3.15	Teflon	2.1
Nylon	3.4	Water	80

## Induced Charge

In the last discussion we discovered that if we put a dielectric inside a capacitor, we end up with polarized charges with the net result that there will be excess negative charge near the positive plate of the capacitor, and excess positive charge near the negative plates of the capacitor. In the middle of the dielectric, the charges are polarized in each atom. But still, for any volume inside, the net charge is zero. The excess charge near each plate we will call the *induced charge*.

Since we have an induced positive charge on one side and an induced negative charge on the other side, we expect there will be an electric field directed from the positive to negative charge inside the dielectric.

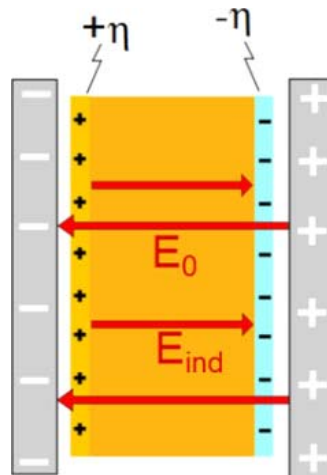

Let’s attempt to find the induced charge density on the dielectric. The total field inside the dielectric is

$$E = E_o - E_{ind} \tag{16.8}$$

where  $E_o$  is the field due to the capacitor plates. From our previous discussion, we recall that

$$\Delta V = \frac{\Delta V_o}{\kappa}$$

and we recall that the magnitude of the potential difference is given by

$$\Delta V = Ed$$

Then our new net field can be found

$$Ed = \frac{E_o d}{\kappa}$$

or

$$E = \frac{E_o}{\kappa}$$

and, recalling for a parallel plate capacitor (near the center) the field is approximately

$$E = \frac{\eta}{\epsilon_o}$$

then

$$E = E_o - E_{ind}$$

gives

$$\frac{\eta}{\kappa \epsilon_o} = \frac{\eta}{\epsilon_o} - \frac{\eta_{ind}}{\epsilon_o}$$

and we can find the induced surface charge density as

$$\eta_{ind} = \eta \left( 1 - \frac{1}{\kappa} \right)$$

You might guess that the induced charge is attracted to the charge on the plates, so a force is required (and work is required) to remove the dielectric once it is in place. If we draw out the dielectric, we can see that the weaker field outside the capacitor causes little induced charge, but the stronger field inside the capacitor causes a large induced charge. A net inward force will result.

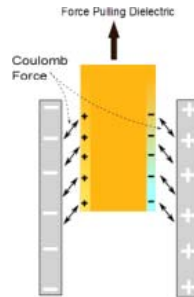

## Electric current

Question 223.35.4

Question 223.35.5

For some time now, we have been talking about charge moving. We have had charge

move from a battery to the plates of a conductor. We have had charge flow from one side to another of a conductor, etc. It is time to become more exact in describing the flow of charge. We should take some time to figure out why charge will move.

Let's consider a conductor again.

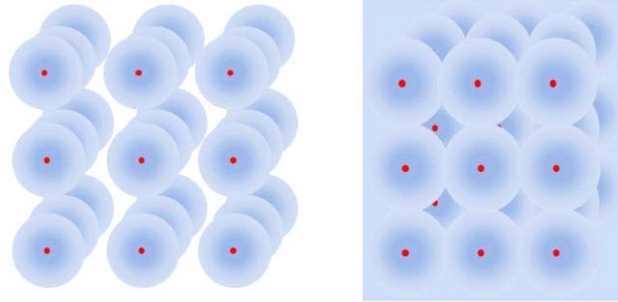

Insulator

Conductor

We remember that in the conductor, the valence electrons are free to move. In fact, they do move all the time. The electrons will have some thermal energy just because the conductor is not at absolute zero temperature. This thermal energy causes them to move in random directions. (think of air molecules in a room).

Let's take a piece of a wire  $\Delta x$  long. The speed of the electrons along the wire (in the  $x$ -direction in this case) is called the *drift speed*,  $v_d$ , because the electrons just drift from place to place with a fairly small speed. This drift speed could be due mostly to thermal energy, so it can be very small or even zero (if no electric potential is applied). Of course,  $v_d$ , must be an average, each charge carrier will be moving random directions with slightly different speeds, so the  $x$ -component of the velocity will be different for each charge carrier, but on average they will move at a speed  $v_d$ .

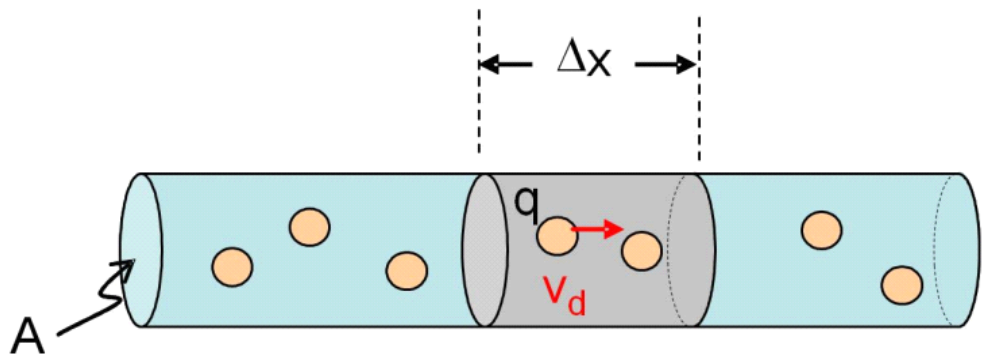

So we will suppose that there are charge carriers of charge  $q_c$  that are moving through the wire with velocity  $v_d$ . Then we can write some length of wire,  $\Delta x$ , as

$$\Delta x = v_d \Delta t$$

The volume of the shaded piece of wire is

$$\mathbb{V} = A \Delta x$$

Question 223.35.6

if there are

$$n = \frac{\#}{\mathbb{V}}$$

charge carriers per unit volume, a *volume charge carrier number density*, then the total charge in our volume is

$$\Delta Q = n A \Delta x q_c$$

If we have electrons as our charge carrier, then  $q_c$  is just  $q_e$ .

We can substitute for  $\Delta x$

$$\Delta Q = n A v_d \Delta t q_c$$

This gives the charge within our small volume. But it would be nice to know how much charge is going by, because we want moving charge. We can divide by  $\Delta t$

$$\frac{\Delta Q}{\Delta t} = n A v_d q_c \quad (16.9)$$

to get a charge flow rate. This is very like our volume or mass flow rate in fluid flow.

We have an amount of charge going by in a time  $\Delta t$ .

I gave the flow velocity a special name,  $v_d$ . But I did not give all the reasons for using an average  $x$ -component of the velocity. But if we think about it, we will realize that the electrons don't really flow in a straight line. They continually bump into atoms<sup>14</sup>. So the actual path the electrons take looks more like this.

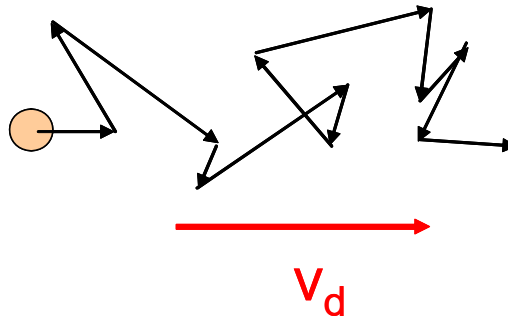

We only care about the forward part of this motion. It is that forward component that we call the *drift speed* of the electrons. It is much slower than the actual speed the

<sup>14</sup> We will refine this picture in the next lecture.

electrons travel, and it depends on the type of conductor we are using.

We already know the name for the flow rate of charge, it is the electric current.

$$\frac{\Delta Q}{\Delta t} = I \quad (16.10)$$

We should take a minute to think about what to expect when we allow charge to flow. Think of a garden hose. If the hose is full of water, then when we open the faucet, water immediately comes out. The water that leaves the faucet is far from the open end of the hose, though. We have to wait for it to travel the entire length of the hose. But we get water out of the hose immediately! Why? Well, from Pascal's principle we know that a change in pressure will be transmitted uniformly throughout the fluid. This is like your hydraulic brakes. The new water coming in causes a pressure change that is transmitted through the hose. The water at the open end is pushed out.

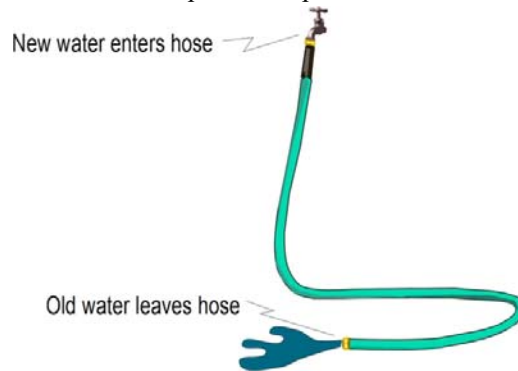

Current is a little bit like this. When we flip a light switch, the electrons near the near the switch start to flow at  $v_d$ . But there are already free electrons in all the wire. These experience a Pascal's-principle-like-push that makes the light turn on almost instantly.

Question 223.35.7

There is a historical oddity with current flow. It is that the current direction is the direction positive charges would flow. This may seem strange, since in good conductors, we have said that electrons are doing the flowing! The truth is that it is very hard to tell the difference between positive charge flow and negative charge flow. In fact, only one experiment that I know of shows that the charge carriers in metals are electrons.

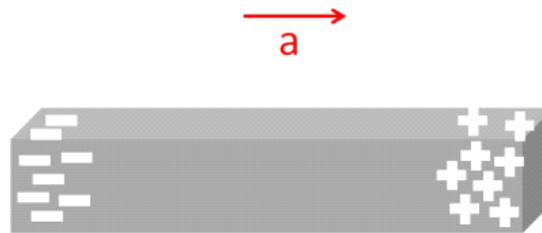

That experiment accelerates a conductor. The experiment is easier to perform using a centrifuge, but it is easier to visualize with linear motion. If we accelerate a bar of metal as shown in the preceding figure, the electrons are free to move about in the metal but the nuclei are all bound together. If the nuclei are accelerated they must go as a group. But the electrons will tend to stay with their initial motion (Newton's first law) until the end of the bar reaches them. At this point they must move because the electrical force of the mass of nuclei will keep them bound to the whole mass of metal. But the electrons will pile up at the tail end of the bar—that is—if it is the electrons that are free. When this experiment is performed, it is indeed the electrons that pile up at the tail end, and the forward end is left positive. This can be measured with a voltmeter.

Ben Franklin chose the direction we now use. He had a 50% chance if getting the charge carrier right. All this shows just how hard it is to deal with all these things we can't see or touch. And even more importantly, in semiconductors and in biological systems, it *is* positive charge that flows. In many electrochemical reactions *both* positive and negative charges flow. We will stick with the convention that the current direction is the direction that positive charges would flow regardless of the actual charge carrier sign.

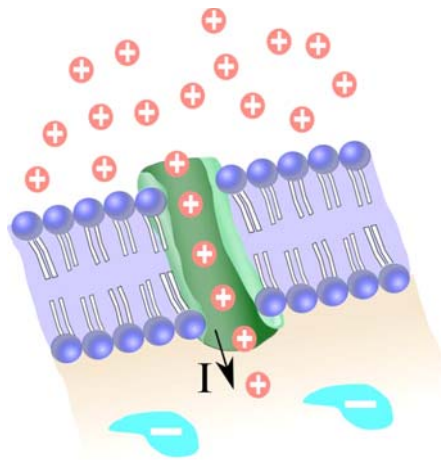

Flow of positive charge through a gate into a neural cell.



## Basic Equations

Voltage if a dielectric is placed between the plates of the capacitor (equation 16.5)

$$\Delta V = \frac{\Delta V_o}{\kappa}$$

Capacitance increases (equation 16.5)

$$C = \kappa C_o$$

For parallel plate capacitors we get

$$C = \kappa \epsilon_o \frac{A}{d}$$

The induced field in a dielectric is (equation 16.8)

$$E = E_o - E_{ind}$$

Current is the rate of charge flow (equation 16.10)

$$\frac{\Delta Q}{\Delta t} = I$$

Definition of current (equation 16.9)

$$I = nAv_d q_c$$



# 17 Current, Resistance, and Electric Fields

## Fundamental Concepts

- There is a nonconservative (friction-like) force involved in current flow called *resistance*.
- A nonuniform charge distribution creates an electric field, which provides the force that makes current flow
- Current flow direction is defined to be the direction positive charge carriers would go
- The current density is defined as  $J = nq_e v_d$
- Charge is conserved, so in a circuit, current is conserved.
- The material property of a conductor that tells us how well the conductor material will allow current to flow through it is called the conductivity
- The inverse of conductivity is the resistivity
- Resistivity may be temperature dependent
- Resistance depends on the resistivity of the material and the geometry of the conductor piece. For a wire it is given by  $R = \rho A/L$
- For many conductors, the change in voltage across the conductor is proportional to the current and the resistance. This is called Ohm's law
- The ideal voltage delivered by a battery is called the "emf" and is given the symbol  $\mathcal{E}$
- Some materials do not follow Ohm's law. They are called nonohmic

### Current and resistance

Question 223.36.1

We now have flowing charges, but our PH121 or Dynamics experience tells us that there is more. If we push or pull an object, we expect that most of the time there will be dissipative forces. There will be friction.

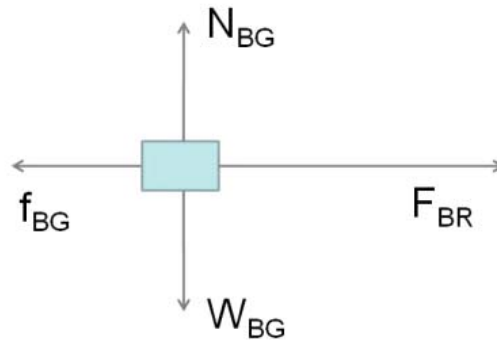
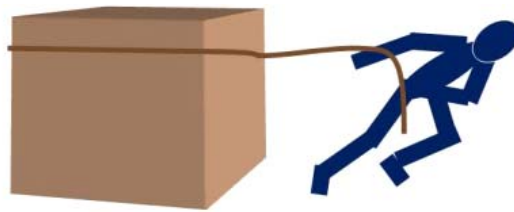

Question 223.36.2

We should ask, is there a friction involved in charge movement? We already know how to push a charge, we use an electric field

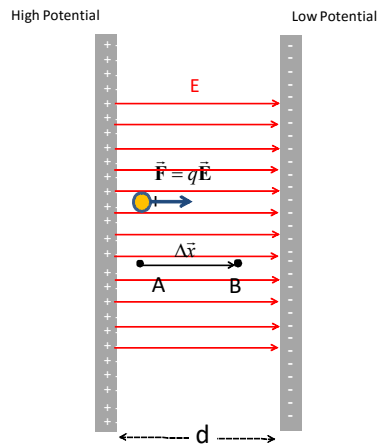

The force is

$$F = qE$$

If we push or pull a box, it will eventually come to rest. In our capacitor there are no resistive forces for our charge to encounter. But suppose we place a conductor inside our capacitor, hooked to both plates

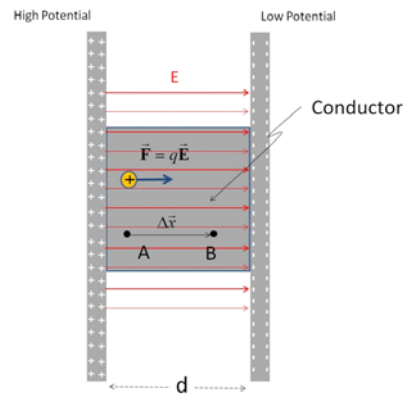

Question 223.36.3

Of course, in conductors we now know the charge carrier is an electron and it is negative, so let's try to redraw this picture to show the actual charge motion.

Now the charge is free to move inside of the conductor, but it is not totally unencumbered. The free charges will run into the nuclei of the atoms. The charges will bounce off. So as they travel through the material we will expect to see some randomness to their motion. This is compounded by the fact that the electrons already have random thermal motion. So the path the charge takes looks somewhat like this

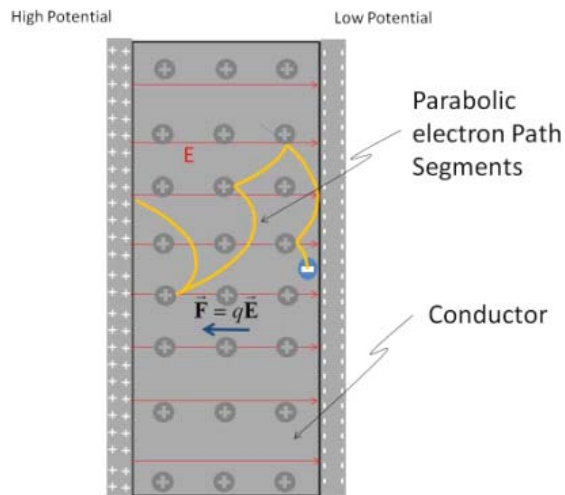

We can recognize that each path segment after a collision must be parabolic because the acceleration will be constant

$$F = ma = qE$$

so

$$a = \frac{qE}{m}$$

we can describe the electron motion using the two of the kinematic equations

$$\begin{aligned}x_f &= x_i + v_{ox}\Delta t + \frac{1}{2} \left( \frac{qE}{m} \right) \Delta t^2 \\v_{fx} &= v_{ix} + a_x \Delta t\end{aligned}$$

Which we recognize as a parabolic path.

Of course, this is just for one electron, and only for a segment between collisions. We will have millions of electrons, and therefore, many millions of bounces. But for each electron, between bounces we expect a parabolic path. For considering current flow, we don't care about motion perpendicular to the current direction. So we can look only at the component of the motion in the flow direction. The net flow in the current direction is toward the positive plate. Let's see how this works.

Question 223.36.4

If we average the velocities of all the electrons we find

$$\begin{aligned}v_d &= \bar{v}_x \\ &= \bar{v}_{ix} + a_x \Delta \bar{t}\end{aligned}$$

the first term  $\bar{v}_{ix} = 0$  because the initial velocities are random from the thermal and scattering processes. That is, on average, the electrons have no preferred direction after a bounce. This leaves

$$v_d = \left( \frac{qE}{m} \right) \Delta \bar{t}$$

The average time between collisions,  $\Delta \bar{t}$ , is sometimes given the symbol  $\tau$ . Let's use this. Recall that current is

$$I = nAv_d q_c$$

Then, if we rearrange our equation for  $v_d$

$$v_d = \left( \frac{q\tau}{m} \right) E$$

we can write our current equation as

$$I = nqA \left( \frac{q\tau}{m} \right) E$$

We have shown that the current is directly proportional to the field inside the conductor. It is this field that causes the charges to flow. We are right back to an environment (field) and mover charges (electrons)!

Question 223.36.5

But let's look even closer. Suppose we connect our two plates with a wire instead of filling their gap with a conductor. If current flows through the wire, there must be a field in the wire. But how does it get started?

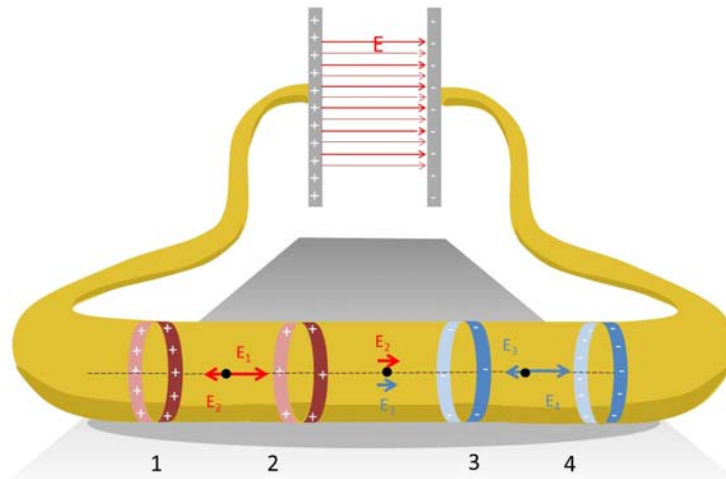

This figure is supposed to show our wire connected to the capacitor. The capacitor is in the background, and the wire loops close to us. The end of the wire that is connected to the positive side of the capacitor will become positively charged, and the end connected to the negative side of the capacitor will become negatively charged. But if we look at the wire an infinitesimal time after the connection has happened, the wire will not be uniformly charged. It will take some time for the charges to reach equilibrium (if you have taken ME210, think of RC circuits). In the mean time, the charge is stronger near the plates, and diminishes toward the middle.

We can't find the exact field in the conductor without resorting to a computational solution, but we can mentally model the situation by viewing the wire as consisting of rings of charge that vary in surface charge density. We know the field along the axis due to a ring of charge because we have done this problem in the past.

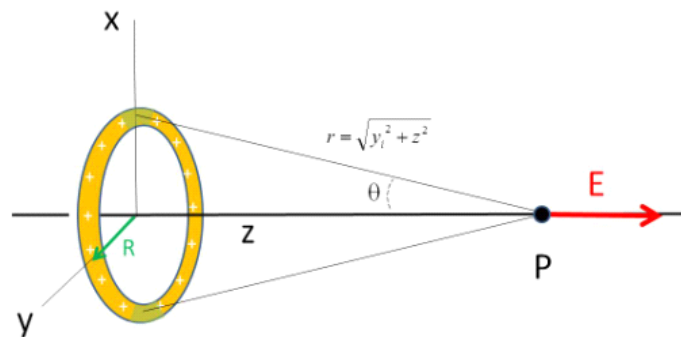

$$\vec{E} = \frac{1}{4\pi\epsilon_0} \frac{zQ}{(R^2 + z^2)^{\frac{3}{2}}} \hat{k}$$

We know the field is along the axis and that it diminishes with distance from the ring. Now consider the field due to ring 1. As we move to the right, away from ring 1 that field will diminish with distance. Also consider the field due to ring 2. As we move to the right toward ring 2 the field due to ring two will grow. The field due to ring two grows at the same rate that the field from ring 1 diminishes. The fields 1, and 2 add up to a constant value along the axis for every point in between the two rings. Now consider the field on the right side of ring 2 and the field on the left side of ring 3. A little thought shows that the situation is the same as that for rings 1 and 2. We will have a constant net field between the two rings.

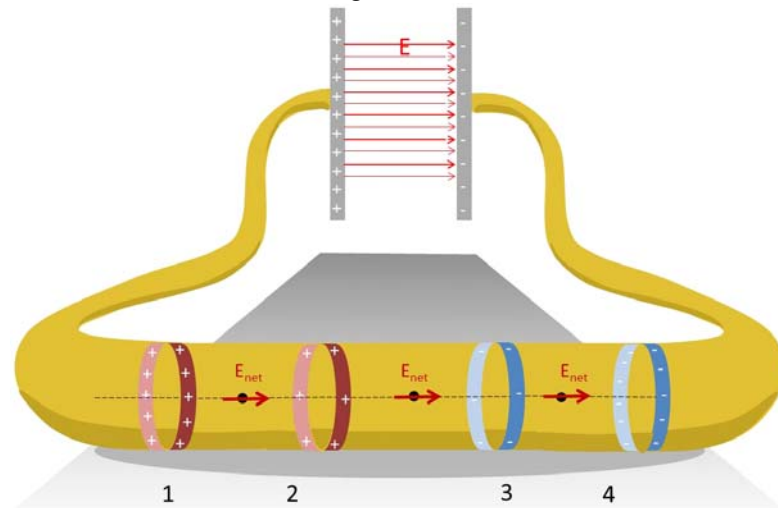

Likewise for the region between rings 3 and 4. There is a constant net electric field at all points along the wire. This field points from positive to negative. It will exert a force

$$F = qE_{net}$$

on the free charges *inside* the wire. These free charges are not extra charge. They are the free electrons that are loosely attached to the metal atoms that make up the wire. So these free charges are distributed throughout the volume of the wire. These free charges will accelerate, forming a current inside the wire.

Note that these free charges are not just on the surface, they are inside the wire, even on the axis of the wire in the center. We no longer have a static equilibrium, so we no longer have excess charge only on the surface.

All this usually happens very fast, so when we switch on a light, we don't notice the time it takes for the current to start. But this uneven distribution of charge is the reason we get a current.



## Current density

Question 223.36.6

We now realize that when there is an electric field inside a wire, there will be current flow inside the wire. The flow goes through the volume of the wire.

The rate of flow is given by

$$I = \frac{\Delta Q}{\Delta t} = nq_e A \left( \frac{q_e \tau}{m_e} \right) E$$

for steady current flow. Here we are writing  $q = q_e$  for the electron charge and  $m = m_e$  for the electron mass, since our charge carrier is an electron..

The unit for current flow is

$$\frac{\text{C}}{\text{s}} = \text{A}$$

Question 223.36.7

where A is the symbol for an *Ampere* or, for short, an *amp*.

Historically there was no way to tell whether negative charges were flowing or whether positive charges were flowing. It really did not matter so much in the early days, since a flow of positive charges one way is equivalent to a flow of negative charges the other way.

Case 1: Negative charges flow to the right



Result: Left side is more positive than before,  
Right side is more negative than before

Case 2: Negative charges flow to the right

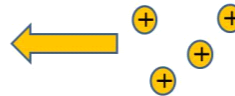

Result: Left side is more positive than before,  
Right side is more negative than before

Worse, we know that for some systems there are positive charge carriers and for others negative charge carriers.

**By convention, we assign the direction of current flow as though the charge carrier were positive.**

This is great for biologists, where the charge carriers are positive ions. But for electronics this gives us the uncomfortable situation that the actual charge carriers, electrons, move in the direction opposite to that of the current.

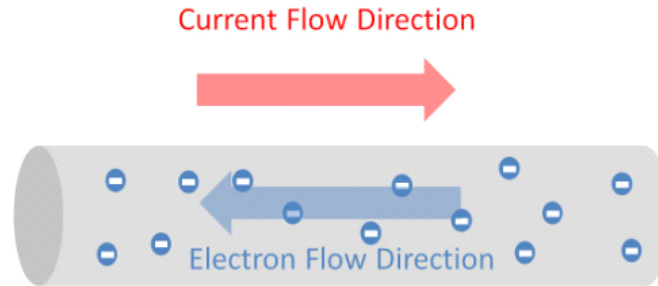

Let's look again at our definition of current

$$I = \frac{\Delta Q}{\Delta t} = nq_e A \left( \frac{q_e \tau}{m_e} \right) E$$

If we, once again, write this in terms of  $v_d$

$$v_d = \left( \frac{q\tau}{m} \right) E$$

then after rearranging, we have

$$I = (nq_e v_d) A$$

Question 223.36.8

the part in parentheses contains only bulk properties of the conductor material, the number of free charges, the charge of the charge carrier, and the drift speed which depends on the material structure of the conductor. The final factor is just the cross sectional area of the wire. It gives the geometry of the wire we have made out of the bulk material (say, copper). It is convenient to group all the factors that are due to bulk material properties

$$J = nq_e v_d$$

then the current would be

$$I = JA$$

Note how similar this is to a surface charge density

$$Q = \eta A$$

For a static charged surface,  $Q$  is the surface charge density multiplied by the particular area. For our case we have a total current,  $I$  that is the material properties multiplied by an area. By analogy we could call this new quantity,  $J$ , a kind of density, but now our charges are moving. So let's call it the *current density*.

Notice that it is the cross sectional area of the wire that shows up in our current

equation. This is another indication that the charge is not flowing along the surface, but that it is deep within the wire as it flows.

**Conservation of current**

Question 223.36.9

Let's go back to our pumps and turbines.

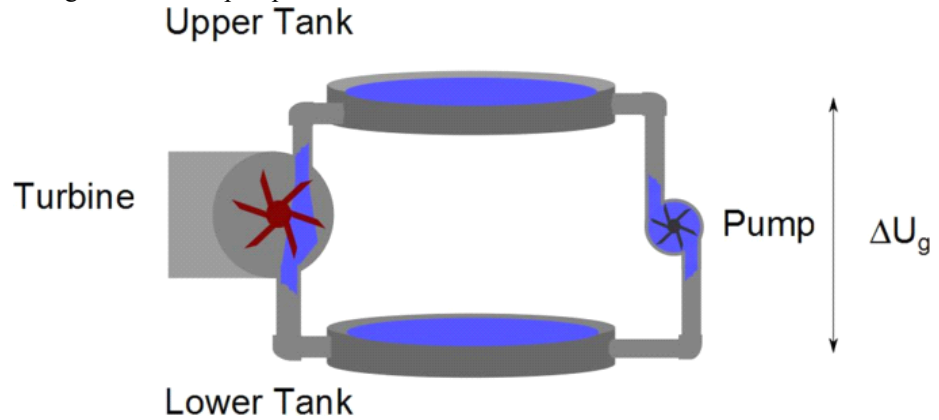

How much of the water is “used up” in turning the turbine? Another way to say this is to ask if there are 20 l of water entering the turbine, how much water leaves the turbine through the lower pipe?

If the turbine leaks, then we might lose some water, but if all is going well, then you can guess that 20 l of water must also leave the turbine. We can't lose or gain water as the turbine is turned. But we must be losing something! We must be giving up something to get useful work out of the system. That something that we lose is potential energy.

Question 223.36.10

Now consider a battery. How much of the current is “used up” in making the light bulb light up?

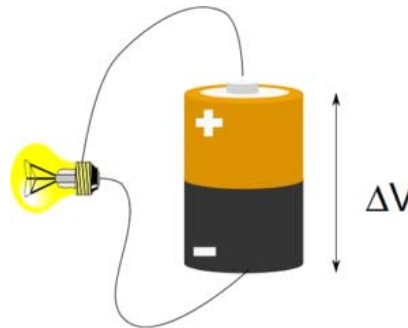

This case is really the same as the water case. The electric current is a flow of electrons. The flow loses potential energy, but we don't create or destroy electrons as we convert the potential energy of the battery to useful work (like making light) just like we did not create or destroy water in making the turbine turn.

But surely the water slowed down as it traveled through the turbine—didn't it? Well, no, if the water slows down as it goes through the turbine, then the pipe below the turbine would run dry. This does not happen. The flow rate through a pipe does not change under normal conditions, and under abnormal conditions, we would destroy the pump or the turbine! If we throw rocks off a hill, they actually gain speed when the water loses potential energy. Now the flow rate is slower with a turbine in the pipe than it would be with no turbine in the pipe! But with the turbine in the pipe, the flow rate is the same throughout the whole pipe system.

Like the water case, the flow rate of charge does not change from point to point in the wire. The same amount of charge per unit time leaves the wire as went in.

This explains the reasoning behind one of the great laws of electronics

---

The current is the same at all points in a current-carrying wire.

---

Like in the water case, the electrons would flow faster if there were no light bulb and just a continuous wire. We can have different flow rates in our wire depending on how much resistance there is to the flow. But the flow rate will be the same in all parts of the wire system.

This leads to the second of the pair of rules called Kirchhoff's laws:

$$\sum I_{in} = \sum I_{out}$$

If the wire branches into two or more pieces, the current will divide. This is not too surprising. The same is true for water in a pipe

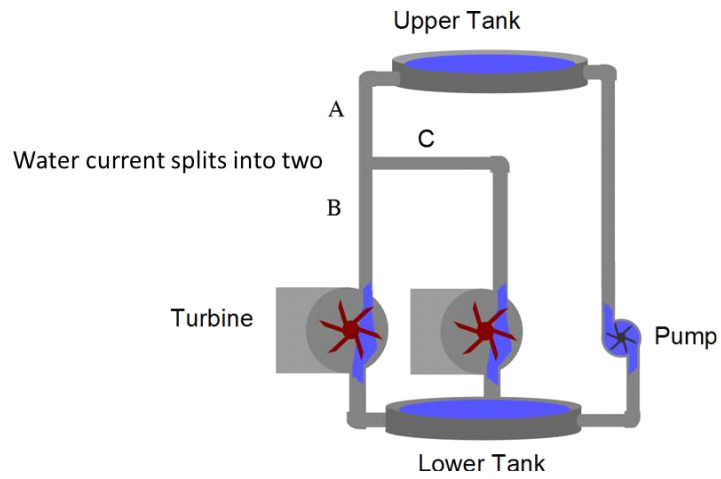

In the figure the flow through pipe segment *A* is split into two smaller currents that flow through pipe segments *B* and *C*. We would expect that the flow through *B* and *C* combined

Question 223.36.12 must be equal to the flow through *A*.

The same must be true for electrical current. The situation is shown in the next figure.

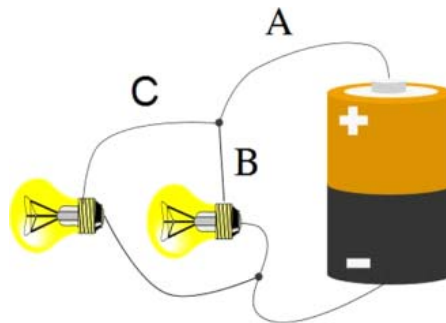

Question 223.36.13 The current that flows through wires *B* and *C* combined must be equal to the current that came through wire *A*.

## Basic Equations



# 18 Resistance

## Conductivity and resistivity

We talked in our last lecture about resistance to electric current. We can see where that resistance might come from. We have electrons bouncing off of atoms in the conductor. Some of the collision energy will be converted into thermal energy of the atoms. Then, different materials will have different amounts of friction, and even different crystal structures of the same material will act differently. We need a way to describe how easily a current can go through a material. Let's look at our equations and see if we can find an easy expression for the material properties of the conductor that tell us how well current can flow through it.

Question 223.37.1

We defined the current density last lecture

$$J = nq_e v_d$$

but we know that the drift speed is

$$v_d = \left( \frac{q_e \tau}{m_e} \right) E$$

so we can write the current density as

$$\begin{aligned} J &= nq_e \left( \frac{q_e \tau}{m_e} \right) E \\ &= \left( \frac{nq_e^2 \tau}{m_e} \right) E \end{aligned}$$

The factor in parentheses depends only on the properties of the conducting material. For example, if the material is copper, then we would have the  $n_{copper} = 8.5 \times 10^{28} \frac{1}{\text{m}^3}$  as the number of valence electrons per unit meter cubed for copper. The mean time between collisions is something like  $\tau_{copper} = 2.5 \times 10^{-14} \text{ s}$ . So our quantity in

parentheses is

$$\begin{aligned} \left( \frac{nq_e^2\tau}{m_e} \right) &= \frac{(8.5 \times 10^{28} \frac{1}{\text{m}^3}) (1.6 \times 10^{-19} \text{ C})^2 (2.5 \times 10^{-14} \text{ s})}{9.11 \times 10^{-31} \text{ kg}} \\ &= 5.9715 \times 10^7 \frac{\text{A}^2 \text{ s}^3}{\text{m}^3 \text{ kg}} \\ &= 5.9715 \times 10^7 \frac{1}{\Omega \text{ m}} \end{aligned}$$

The field is due to something outside of the conducting material (e.g. the charge on the battery terminals and the extra charge supplied). Again we have grouped all the properties of the material together. Let's give a name to the quantity in parentheses that contains all the material properties. Since this quantity tells us how easily the charges will go through the conductive material, we can call this the *conductivity* of the material.

$$\sigma = \frac{nq_e^2\tau}{m_e}$$

Then

$$J = \sigma E$$

The current density depends on two things, how well the material can allow the current to flow (bulk material properties related to conduction),  $\sigma$ , and the field that makes the current flow,  $E$ .

The current, then, depends on these two items, as well as the cross sectional area of the wire

$$\begin{aligned} I &= JA \\ &= \sigma EA \end{aligned}$$

Really, the conductivity is more complicated than it appears. The mean time between collisions,  $\tau$ , depends on the structure of the conductor. Different crystalline structures for the same element will give different values. Think of trying to walk quickly through the Manwering Center crowds during a class break. This takes some maneuvering. But if all the people were placed at equally spaced, regular intervals, it might be easier to make it through quickly. It would also be easier if the crowd stood still. Likewise, the position of the atoms in the conductor make a big difference in the conductivity, and thermal motion of those atoms also makes a large difference. We would expect the conductivity to depend on the temperature of the material.



## Resistivity

Question 223.37.2

It is common to speak of the opposite of the concept of conductance. In other words, how hard it is to get the electrons to travel through the conductive material. For example, we might want to build a heating device, like a toaster or space heater. In this case, we want friction in the wires, because that friction will produce heat. So specifying a conductive material by how much friction it has is useful. How much the material impedes the flow of current is the opposite of how much the material allows the current flow, so we expect this new quantity to be the inverse of our conductivity

$$\rho = \frac{1}{\sigma} = \frac{m_e}{nq_e^2\tau}$$

Special conductors are often made that use “impurities,” that is, trace amounts of other atoms, to increase or decrease the resistivity of conductive materials. The thermal dependence can be modeled using the equation

$$\rho = \rho_o(1 + \alpha(T - T_o))$$

where  $\rho_o$  is the resistivity at some reference temperature (usually 20 °C) and  $\alpha$  is a constant that tells us how our particular material changes resistance with temperature. It is kind of like the specific heat in thermodynamics  $Q = C\Delta T$ . This is an approximation. It is a curve fit that works over normal temperatures. But we would not expect the same resistive properties, say, if we melt the material. The position of the atoms would change if the material goes from solid to liquid. So we will need to be careful in how we use this formula.

Here are some values of the conductivity, resistivity, and temperature coefficients for a few common conductive materials.

Question 223.37.3

Material	Conductivity ( $\Omega^{-1} \text{ m}^{-1}$ )	Resistivity ( $\Omega \text{ m}$ )	Temp. Coeff. ( $\text{K}^{-1}$ )
Aluminum	$3.5 \times 10^7$	$2.8 \times 10^{-8}$	$3.9 \times 10^{-3}$
Copper	$6.0 \times 10^7$	$1.7 \times 10^{-8}$	$3.9 \times 10^{-3}$
Gold	$4.1 \times 10^7$	$2.4 \times 10^{-8}$	$3.4 \times 10^{-3}$
Iron	$1.0 \times 10^7$	$9.7 \times 10^{-8}$	$5.0 \times 10^{-3}$
Silver	$6.2 \times 10^7$	$1.6 \times 10^{-8}$	$3.8 \times 10^{-3}$
Tungsten	$1.8 \times 10^7$	$5.6 \times 10^{-8}$	$4.5 \times 10^{-3}$
Nichrome	$6.7 \times 10^5$	$1.5 \times 10^{-6}$	$0.4 \times 10^{-3}$
Carbon	$2.9 \times 10^4$	$3.5 \times 10^{-5}$	$-0.5 \times 10^{-3}$

## Superconductivity

The relationship

$$\rho = \rho_o (1 + \alpha (T - T_o))$$

also breaks down at low temperatures. The low end is very important these days. For some special materials, the resistivity goes to zero when the material is cold enough. We call these materials superconductors. A superconductor can carry huge currents, because there is no loss of energy, and no heat generated without any friction. Unfortunately most superconducting materials only operate at temperatures near absolute zero. But a few “high temperature” superconductors operate at temperatures as high as 125 K. This is still very cold ( $-150^\circ\text{C}$ ), but these temperatures are achievable, so some superconducting products are possible. As you can guess, there is very active research in making superconductors that operate at even higher temperatures.

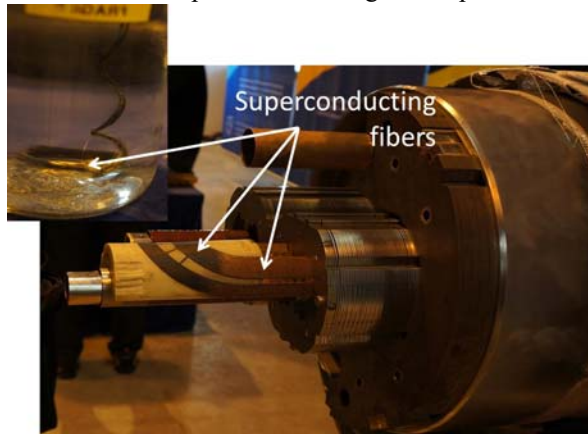

Superconducting fiber material and superconducting magnet at CERN.

# 19 Ohm's law

Let's pause to review

$$\begin{aligned} J &= \sigma E \\ &= \frac{1}{\rho} E \end{aligned}$$

Then the current is given by

$$\begin{aligned} I &= JA \\ &= \frac{A}{\rho} E \end{aligned}$$

The field is similar to our capacitor field, nearly uniform in our conducting wire

$$\begin{aligned} \Delta V &= Ed \\ &= E\Delta s \end{aligned}$$

so the electric field is approximately given by

$$E = \frac{\Delta V}{\Delta s}$$

for our wire of length  $L$  this is

$$E = \frac{\Delta V}{L}$$

Then we can use this field to write our current

$$I = \frac{A}{\rho} \frac{\Delta V}{L}$$

or rewriting, we have

$$I = \left( \frac{A}{L\rho} \right) \Delta V$$

and rewriting again we have

$$\Delta V = I \left( \rho \frac{L}{A} \right)$$

The part in parenthesis contains all the friction terms. It says that the longer the wire, the more friction we will experience. This makes sense. If you are familiar with fluid flow. The longer the hose, the more resistance. It also says that the larger the area, the lower the friction. That is also reasonable, since the electrons will have more places to go unrestricted if the area is bigger. In water flow, the larger the pipe, the less the water interacts with the sides of the pipe and therefore the lower the friction. This situation is analogous.

We should give a name to this quantity that describes the frictional properties of the wire. We will call it the *resistance* of the wire.

$$R = \rho \frac{L}{A}$$

so that we can write

$$I = \frac{\Delta V}{R}$$

The resistance has units of

$$\frac{\text{V}}{\text{A}} = \Omega$$

where  $\Omega$  is given the name of *ohm* after the scientist that did pioneering work on resistance.

The relationship

$$I = \frac{\Delta V}{R}$$

is called *Ohm's law*.

## Life History of an electric current

Let's go back and think about our pump model for a battery.

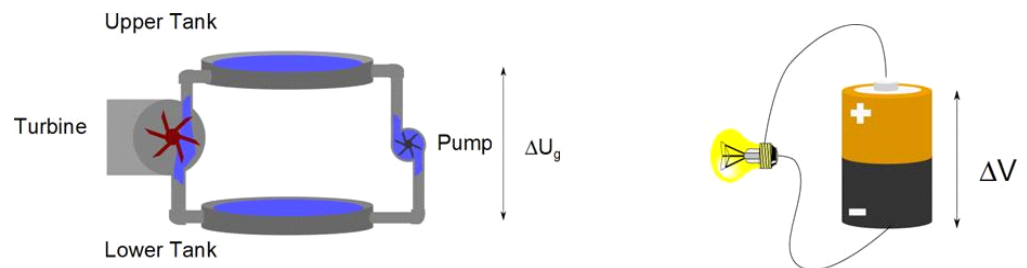

The pump is a source of potential energy *difference*. This is what a battery does as well. The battery is a charge pump. It moves the charges from a low to a high potential. So it is a source of electric potential. The battery's job is to provide the charge separation that creates the electric field that drives the free charges, making the current.

A positive charge in the wire on the negative side of the battery is pumped up to the positive side through a chemical process. We can mentally envision a small charge pump inside of the battery

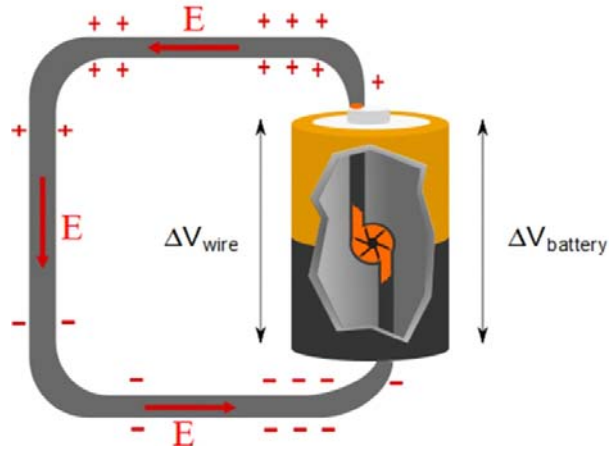

The battery is the source of the potential. A positive charge near the negative side of the battery would be pumped up to the positive side of the battery. It would gain potential energy

$$\Delta U_{battery} = q\Delta V_{battery}$$

Then it would “fall” down the wire. It must lose all of the potential energy it gained. So it will lose

$$|\Delta U_{wire}| = |\Delta U_{battery}|$$

but if the battery potential energy change is positive, the wire change must be negative. We can see that

$$\Delta V_{wire} = -\Delta V_{battery}$$

so the potential change in the wire is negative. We sometimes call this a potential “drop.”

The field forces our charge to move through this wire much like the gravitational field forces rocks to fall. The positive charge ends up at the negative end of the battery again, ready to be pumped up to make another round.

of course, really this process goes backwards, since our charge carriers are negative, but we recall that mathematically negative charges going the opposite way is the same. So we will make this picture our mental model of a current.

## Ohmic or nonohmic

Question 223.37.5

This simple model of resistance is great for understanding simple things. Wires, and

resistors do work like this. If we were to take a set of measurements of  $\Delta V$  and  $I$ , we expect a straight line

$$y = mx + b$$

$$\mathcal{E} = \Delta V = RI + 0$$

where  $R$  is the slope.

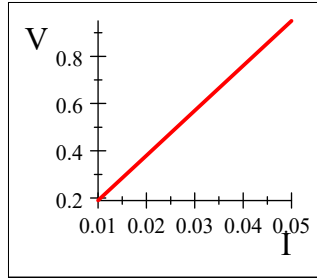

But there are times when the model fails terribly. An incandescent light bulb is an example that we can quickly understand. The resistance at any one moment fulfills Ohm's law

$$I = \frac{\mathcal{E}}{R}$$

but light bulbs get hot. The resistance will change in time. So our relationship is now time dependent. Starting with the resistivity,

$$\rho = \rho_o (1 + \alpha(T - T_o))$$

let's multiply both sides by  $A/L$ .

$$\frac{A}{L}\rho = \frac{A}{L}\rho_o (1 + \alpha(T - T_o))$$

this gives

$$R = R_o (1 + \alpha(T - T_o))$$

So if the resistance is temperature dependent, the slope of the line will change as we go along making measurements. We might get something like this

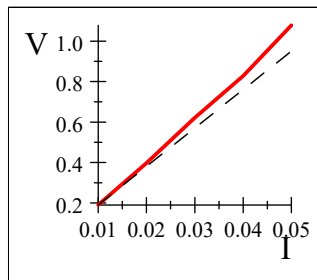

The dashed line is what we expect from Ohm's law. The solid line is what data from a

light bulb would actually look like. We could use our temperature dependent resistance, and realize that the temperature is a function of time, to obtain

$$I = \frac{\mathcal{E}}{R_o (1 + \alpha (T(t) - T_o))}$$

Since this set of measurements is not strictly following Ohm's law, we will say that the light bulb is *nonohmic*.

Many common circuit elements vary nonohmic. A diode, for example, has a  $\Delta V$  vs.  $I$  relationship that looks like this.

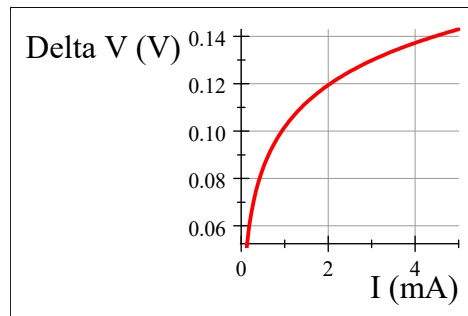

We can now understand how an electric current is formed. We should take some time to study the basics of how to build electric circuits. We will do that in the next few lectures.

## Electronic symbols

In our problems we will need to be able to draw diagrams. There are standard symbols for things like batteries, capacitors, and resistors. It will be convenient to use these symbols. So here are some symbols to learn.

Wire



Junction of two Wires



Switch



Capacitor



Battery



Resister



Light Bulb



These are basic symbols, and they are not universal, sadly. But they are fairly standard, so you should recognize components in circuit diagrams you may see.



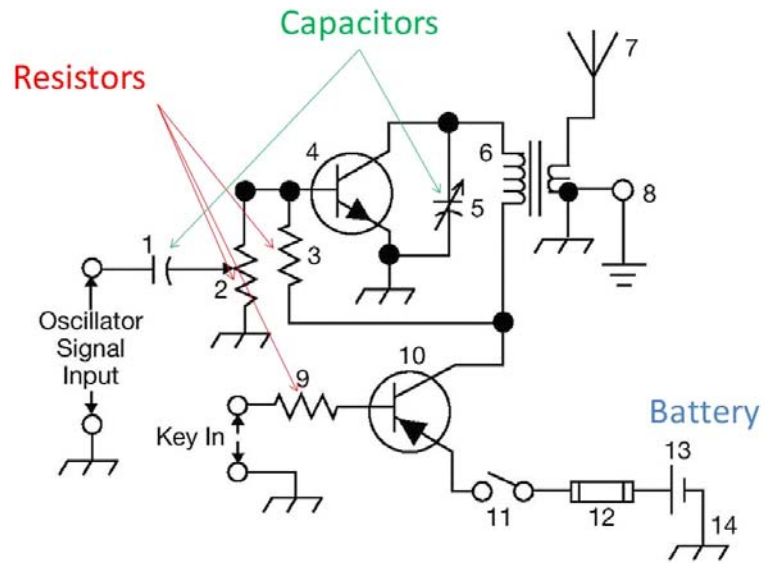

The figure above is from the FCC Amateur Radio examination. You can see that we can already identify several of the symbols from our chart. We can also see that there are others that we have yet to learn!



# 20 Kirchoff's Rules for Direct Current Circuits

## EMF

Once again, we need to introduce a quantity that has an historic name. Let's save the name for last (since it is kind of dumb).

We have thought of a battery as a "charge pump," something that takes charge from a low potential to a high potential. This is like a water pump taking water from a low tank to a high tank. Once the water is at the higher tank, it can be used to do work by allowing it to flow back down to the lower tank (and move paddle wheels or something along the way). As usual, we want to think of the work per unit charge done by this "charge pump." We will give a "charge pump" a new name. We will call it the *source of emf* and write it with the symbol  $\mathcal{E}$ . What does emf stand for? I am not going to tell you, because the original meaning is historical and was very wrong. But we have a long tradition of calling a "charge pump" a source of emf, so we have to keep using this term. Think of Kentucky Fried Chicken changing to KFC so we don't have to say "fried chicken" and think of the calories. There is only a small difference between an emf and a voltage difference. A difference that we will discuss in a lecture or two. So for now, really we are just naming the  $\Delta V$  of a battery  $\mathcal{E}$  and calling it by a nickname emf.

## Conservation of Charge (Reprise) and Conservation of Energy

A few lectures ago, we studied conservation of charge for a circuit.

$$\sum I_{in} = \sum I_{out}$$

If the wire branches into two or more pieces, the current will divide. This is not too surprising. The same is true for water in a pipe

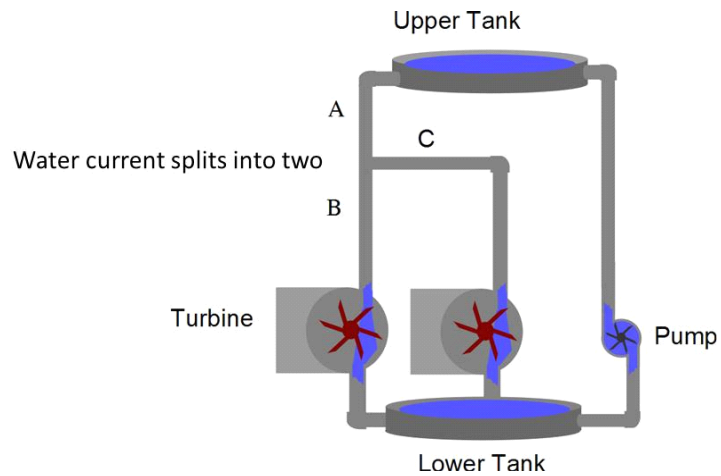

Question 223.36.12

In the figure the flow through pipe segment  $A$  is split into two smaller currents that flow through pipe segments  $B$  and  $C$ . We would expect that the flow through  $B$  and  $C$  combined must be equal to the flow through  $A$ .

The same must be true for electrical current. The situation is shown in the next figure.

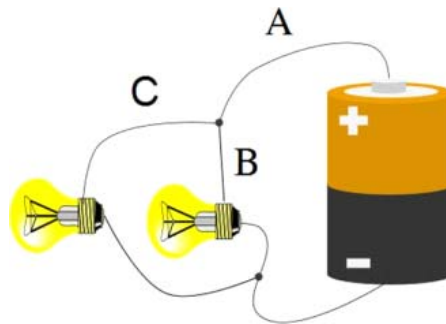

Question 223.36.13

The current that flows through wires  $B$  and  $C$  combined must be equal to the current that came through wire  $A$ .

This is really a statement of the idea of *conservation of charge*. As the charge flows through the circuit, no electrons get lost, and no electrons are created. An early researcher's name is applied to this relationship. It is called *Kirchoff's junction rule*.

We can combine this with another conservation law, *conservation of energy*.

## Combinations in series and parallel

We discovered the rules for adding capacitors in parallel and series, now let's do the same for resistors

### Series Resistances

#### Series connection of light bulb demo

If we add light bulbs in series, the lights are individually dimmer than if we just had one bulb. We can conclude that adding in lights must reduce the current. The lights are resistors<sup>15</sup> and this is true for any resistor

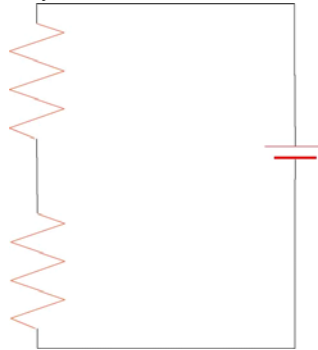

We say the current through the circuit must be the same throughout the whole circuit. We don't build up charge or remove charge anywhere (no capacitors yet). But the potential is not the same at each point in the circuit. Think of a series of water tanks and a pump as shown in the next figure.

<sup>15</sup> But not Ohmic resistors!

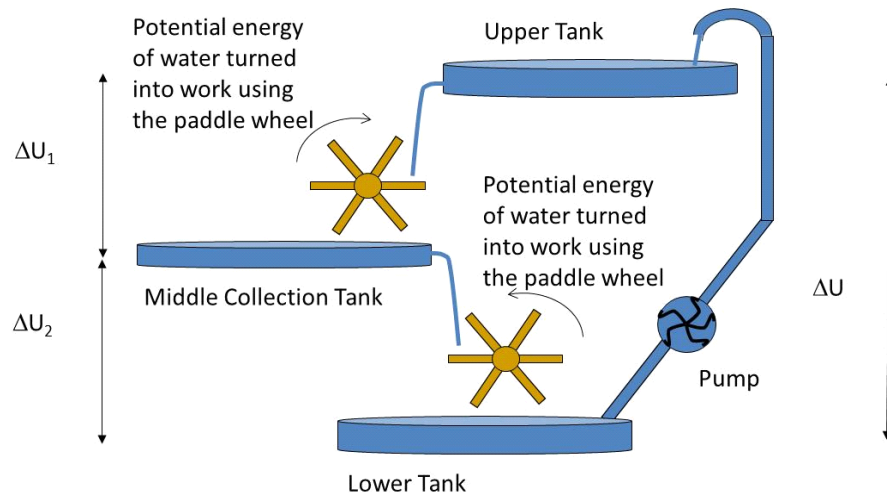

The pump increases the potential energy of the water. The water's potential energy can then be used as it is lowered, first to a tank half way down, then all the way to the lower tank. It is easy to see that

$$\Delta U = \Delta U_1 + \Delta U_2 \quad (20.1)$$

that is, the total energy given up to get to the lower tank is just the energy the pump provided to the water to get it to the upper tank. If we choose the zero point for the potential energy to be the lower tank, then the pump gives a positive  $\Delta U$  and each of the waterfalls give negative  $\Delta U$  values. So we start with zero potential energy, gain potential energy, then lose it in series of steps returning to zero potential energy when the water is back in the lower tank. We could write this as

$$0 = \sum_i \Delta U_i$$

the sum of the potential energy changes must be zero as we go around the water loop. This is conservation of energy. No energy has been lost. We start and end with the same value.

In a circuit, we use potential energy per unit charge, but the situation is very much the same.

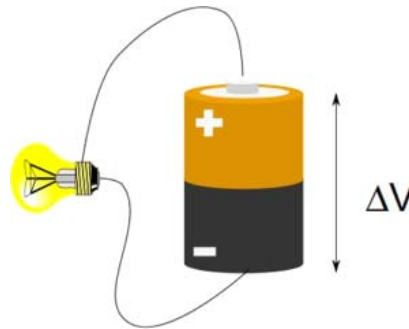

The battery “pumps” the charge to a higher potential. The current “drops” in potential as it goes through resistor  $R_1$  (the top resistor). It also “drops” in potential as it goes through resistor  $R_2$  (the bottom one). Since the charge along the bottom wire must be at the same potential as the negative pole of the battery, we can say that the “drop” in potential for each battery must have used all the potential that was originally supplied by the battery.

$$\Delta V = \Delta V_1 + \Delta V_2 \quad (20.2)$$

If we choose the zero point for the electric potential to be the negative side of the battery, then the battery gives a positive  $\Delta U$  and each of the resistors give negative  $\Delta V$  values. So we start with zero potential at the negative side of the battery, gain potential energy, then lose it in series of steps returning to zero potential when the charge is back at the negative side of the battery. We could write this as

$$0 = \sum_i \Delta V_i$$

the sum of the potential changes must be zero as we go around the current loop. This is also conservation of energy. Electrical potential is potential energy per unit charge, and all our charges are the same, electron charge. So

$$0 = \sum_i \Delta V_i = \frac{1}{q} \sum_i \Delta U_i$$

No energy has been lost. We start and end with the same value.

This is another of the rules cataloged by Kirchhoff and it is called *Kirchhoff's loop rule*.

Now we know that

$$\Delta V = IR$$

We can use this to re-write equation 20.2.

$$\begin{aligned} 0 &= \sum_i \Delta V_i = \Delta V_{battery} + \Delta V_1 + \Delta V_2 \\ &= \Delta V_{battery} - IR_1 - IR_2 \end{aligned}$$

where we see that the voltage drops are negative as we expected. We could rewrite this

as

$$\Delta V = IR_1 + IR_2 \quad (20.3)$$

Since charge is conserved, and we don't allow the charge to pool up or leak out, we can say that the charge in the entire series circuit must be the same. So

$$\Delta V = I(R_1 + R_2) \quad (20.4)$$

Question 220.18.1

## Kirchhoff's Rules

We have collected some good rules for adding resistors and capacitors. Kirchhoff is credited with succinctly stating these rules

- 
1. The sum of the currents entering any junction must equal the sum of the currents leaving that junction. (conservation of charge–junction rule)
  2. The sum of the potential differences across all the elements around any closed circuit loop must be zero (conservation of energy–loop rule)
- 

When we actually apply these rules, we

1. assign symbols and directions to the currents in all branches of the circuit. Don't worry about getting the sign (direction) of the currents right. If you guess wrong, the answer will just be negative, so you will know it really goes the other way
2. When applying the conservation of energy or loop rule, choose a direction for traversing the loop and be consistent. Record potential drops or rises, so you can make sure they sum to zero. Use the following rules.
  - a. If a resistor is traversed in the direction of the current you chose, the change in the potential across the resistor is  $-IR$ . This is a voltage drop.
  - b. If a resistor is traversed in the direction opposite the current you chose, the change in the potential across the resistor is  $+IR$ . This is like going up-hill so the change in potential is positive.
  - c. You must include the source of emf (battery). If it is traversed in the direction of the emf (from  $-$  to  $+$ ) the change in potential is  $+\mathcal{E}$ .
  - d. If the source of emf is traversed in the opposite direction of the emf (from  $+$  to  $-$ ) the change in potential is  $-\mathcal{E}$ . This is like going the wrong way through the water pump. You are going down-hill so you are losing potential energy.

A capacitor acts as a break in the wire; no current flows through the wire (for now, anyway).



Suppose we do an example

## Series Resistances

Let's return to our basic circuit with two resistors. When we had more than one capacitor in a circuit, we found the equivalent

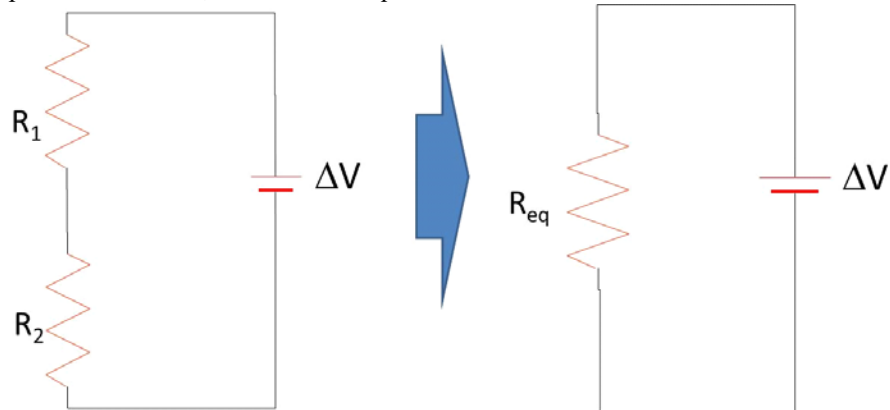

Let's see if we can do this for resistors. We want a single, equivalent resistance  $R_{eq}$  such that

$$\Delta V_{bat} + \Delta V_{eq} = 0$$

where

$$\Delta V_{eq} = IR_{eq}$$

Recall that

$$\Delta V_{bat} = \Delta V_1 + \Delta V_2 \quad (20.5)$$

And

$$\Delta V_{bat} = IR$$

So

$$\Delta V_{bat} = IR_1 + IR_2 \quad (20.6)$$

Since charge is conserved, and we don't allow the charge to pool up or leak out, we can say that the charge in the entire series circuit must be the same. So

$$IR_{eq} = I(R_1 + R_2) \quad (20.7)$$

The current cancels, so we have found what we were looking for. The equivalent resistance is given by.

$$R_{eq} = R_1 + R_2 \quad (20.8)$$

## Examples

Let's try a problem with series resistors. Here is a circuit with two resistors and two batteries. Let's find the current and the voltage drop across each resistor. We need to know that the resistances are  $R_1 = 600\ \Omega$  and  $R_2 = 1000\ \Omega$ . We also need to know the batteries' emfs they are  $\mathcal{E}_1 = 3\ \text{V}$  and  $\mathcal{E}_2 = 9\ \text{V}$ .

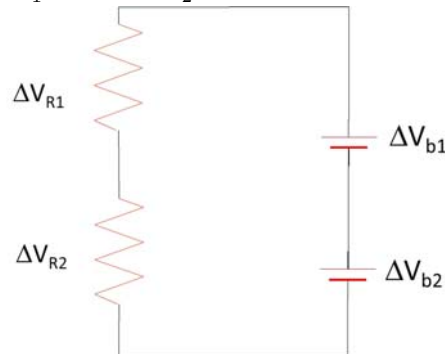

We can use the loop rule to find

$$\Delta V_{b1} + \Delta V_{b2} + \Delta V_{R1} + \Delta V_{R2} = 0$$

Let's envision going counter clockwise around the loop (we get to choose which way we go) and let's envision starting at the negative side of  $b2$ . We also can use Ohm's law

$$\Delta V = IR$$

to write our loop equation as

$$\mathcal{E}_1 + \mathcal{E}_2 - IR_1 - IR_2 = 0$$

$$\mathcal{E}_1 + \mathcal{E}_2 = IR_1 + IR_2$$

$$\mathcal{E}_1 + \mathcal{E}_2 = I(R_1 + R_2)$$

$$\frac{\mathcal{E}_1 + \mathcal{E}_2}{(R_1 + R_2)} = I$$

and we have found the current!

$$\begin{aligned} I &= \frac{3\ \text{V} + 9\ \text{V}}{(600\ \Omega + 1000\ \Omega)} \\ &= 0.0075\ \text{A} \end{aligned}$$

The voltage drop across the resistors is then

$$\Delta V_{R1} = IR_1$$

$$\Delta V_{R2} = IR_2$$

or

$$\Delta V_{R1} = (0.0075\ \text{A})(600\ \Omega) = 4.5\ \text{V}$$

$$\Delta V_{R2} = (0.0075\ \text{A})(1000\ \Omega) = 7.5\ \text{V}$$

we should check our loop rule with our results

$$3\text{ V} + 9\text{ V} + 4.5\text{ V} + 7.5\text{ V} = 0$$

so this solution works!

Let's try another problem.

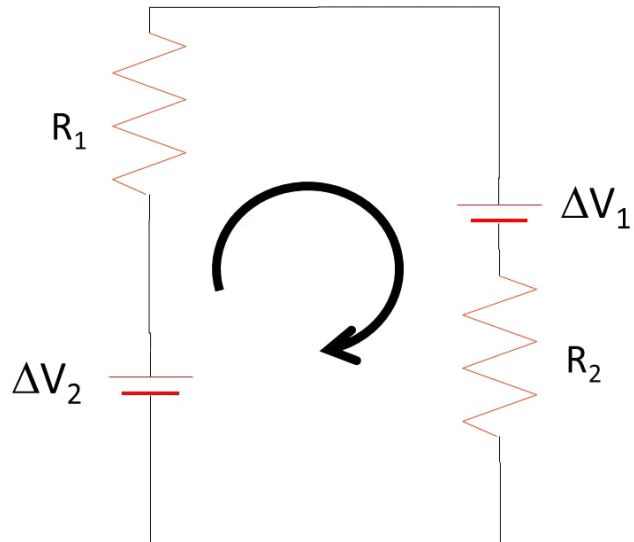

Let's use the same resistors and batteries, but reconfigure them as shown. And let's go clockwise around the loop this time. Let's assume that  $I$  is also clockwise. This is a guess, but if we are wrong, we will just get a negative current, so we will know it goes the other way.

Then, starting on the negative side of  $\Delta V_2$  we have

$$\Delta V_2 + \Delta V_{R1} + \Delta V_1 + \Delta V_{R2} = 0$$

As we go around the loop we go up-hill through  $\Delta V_2$  so  $\Delta V_2 = +\mathcal{E}_2$

$$\mathcal{E}_2 + \Delta V_{R1} + \Delta V_1 + \Delta V_{R2} = 0$$

and we go down hill through  $R_1$  so  $\Delta V_{R1} = -IR_1$

$$\mathcal{E}_2 - IR_1 + \Delta V_1 + \Delta V_{R2} = 0$$

but notice that as we arrive at  $\Delta V_1$  we are going the wrong way through the pump. We are going down hill. So  $\Delta V_1 = -\mathcal{E}_1$

$$\mathcal{E}_2 - IR_1 + -\mathcal{E}_1 + \Delta V_{R2} = 0$$

finally, we are going in the current direction through  $R_2$  so we are going down hill.

$$\Delta V_{R_2} = -IR_2$$

$$\mathcal{E}_2 - IR_1 + -\mathcal{E}_1 + -IR_2 = 0$$

Now we can solve for the current like we did before

$$\mathcal{E}_2 + -\mathcal{E}_1 = IR_1 + IR_2$$

$$\mathcal{E}_2 + -\mathcal{E}_1 = I(R_1 + R_2)$$

$$\frac{\mathcal{E}_2 + -\mathcal{E}_1}{(R_1 + R_2)} = I$$

then

$$I = \frac{9\text{ V} - 3\text{ V}}{(600\ \Omega + 1000\ \Omega)} = 0.00375\text{ A}$$

we got lucky and picked the right direction for the current! From

$$\Delta V_{R_1} = IR_1$$

$$\Delta V_{R_2} = IR_2$$

we can find the potential drop across each resistor

$$\Delta V_{R_1} = (0.00375\text{ A})(600\ \Omega) = 2.25\text{ V}$$

$$\Delta V_{R_2} = (0.00375\text{ A})(1000\ \Omega) = 3.75\text{ V}$$

and once again we check to find

$$9\text{ V} - 2.25\text{ V} + -3\text{ V} + -3.75\text{ V} = 0$$

You might be concerned, It looks like we put one battery in the circuit backwards. Why would we ever do that? But remember when we studied lead acid batteries? To recharge a the battery we had to run the process backward. This means we put the battery in the circuit backwards. There are other reasons we might do this, but one is to make a battery charger.

You might guess that things could get more complicated. An that is certainly true. In the next lecture we will combine resistors and batteries in harder ways, and we will add in capacitors!

## Power in resistors

We learned that the resistance in a resistor depends on the temperature of the resistor, and even have an approximate relationship that shows how this works

$$R = R_o(1 + \alpha(T - T_o))$$

so we know that temperature and resistance are related. But most of us have used a toaster, or an electric stove, or an electric space heater, etc. How does an electric circuit produce heat? or even light from a light bulb?

To answer this let's think of the energy expended as an electron travels a circuit. The potential energy expended is

$$\Delta U = q\Delta V$$

where the  $\Delta V$  comes from the battery, so we could write this as

$$\Delta U = q\mathcal{E}$$

This is the energy lost as the electron travels from one side of the battery to the other. We could describe how fast the energy is lost by dividing by the time it takes the electron to make the trip

$$\frac{\Delta U}{\Delta T} = \frac{q}{\Delta t}\mathcal{E}$$

but of course we want to do this for more than one electron. Let's take a packet of charge,  $\Delta Q$ , then

$$\begin{aligned}\frac{\Delta U}{\Delta T} &= \frac{\Delta Q}{\Delta t}\mathcal{E} \\ \frac{\Delta U}{\Delta T} &= \frac{\Delta Q}{\Delta t}\mathcal{E}\end{aligned}$$

and if we make the packet of charge small we have

$$\frac{dU}{dT} = \frac{dQ}{dt}\mathcal{E}$$

and we recognize  $dU/dt$  as the power and  $dQ/dt$  as current, then

$$\mathcal{P} = I\mathcal{E}$$

This is the power supplied by the battery in moving the group of electrons through the circuit. But from Kirchoff's loop rule, the charge packet must lose all the energy that the battery provides, so

$$\mathcal{P}_{\text{battery}} = \mathcal{P}_R = I\Delta V_R$$

is the energy that leaves the circuit as the packet of charge moves.

This equation is general

$$\mathcal{P}_R = I\Delta V_R$$

so it works for any resistance, but if the resistor is ohmic, then we can use Ohm's law

$$\Delta V_R = IR$$

to find

$$\begin{aligned}\mathcal{P}_R &= I(IR) \\ &= I^2R\end{aligned}$$

but this is only true for ohmic resistors.

But where does this energy go? This is the energy that makes the heat in the space heater, or the light in the light bulb.



# 21 RC Circuits

## Parallel Resistances

We found the equivalent resistance for resistors in series last lecture. You probably thought at the time that we would need an equivalent resistance for resistors in parallel. And you were right. For a parallel circuit, all the top parts of the circuit (see diagram below) are connected to the positive side of the battery. All the bottom parts are connected to the negative side of the battery. Since the connections are with conductors, we can see that the potential “drop” across each resistor must be the same as the potential gain from the battery “pump.” Both branches of the circuit let the current “drop” the same amount.

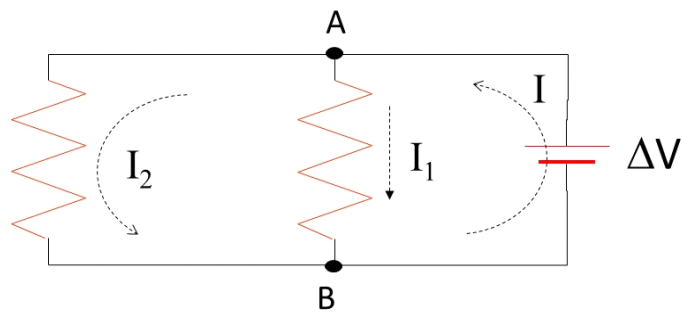

But we can see from charge conservation that the currents in the resistors will not be the same. At point  $A$ , we can see that

$$I = I_1 + I_2 \quad (21.1)$$

again we can use

$$\Delta V = IR$$

but we want to write it as

$$\frac{\Delta V}{R} = I$$

then from the junction rule we see that

$$I_b = I_1 + I_2$$

or

$$\frac{\Delta V}{R_{eq}} = \frac{\Delta V}{R_1} + \frac{\Delta V}{R_2} \quad (21.2)$$

so

$$\frac{1}{R_{eq}} = \frac{1}{R_1} + \frac{1}{R_2} \quad (21.3)$$

We can solve this for the equivalent resistance of the circuit, first get common denominators

$$\frac{1}{R_{eq}} = \frac{1}{R_1} \frac{R_2}{R_2} + \frac{1}{R_2} \frac{R_1}{R_1} \quad (21.4)$$

then add the RHS

$$\frac{1}{R_{eq}} = \frac{R_2 + R_1}{R_1 R_2} \quad (21.5)$$

Now we can invert both sides

$$\frac{R_1 R_2}{R_2 + R_1} = \frac{R_{eq}}{1} \quad (21.6)$$

or

$$R_{eq} = \frac{R_1 R_2}{R_2 + R_1} \quad (21.7)$$

This is always *smaller* than  $R_1$  or  $R_2$ . For example, if  $R_1 = R_2$  then

$$R_{eq} = \frac{RR}{R + R} = \frac{RR}{2R} = \frac{R}{2} \quad (21.8)$$

or the equivalent resistance of the circuit is half the resistance of the individual resistors.

## Emf

We have ignored something in our pump model of a battery. In real water flow, there would be resistance to the flow even inside the pump. This resistance would be small, but not zero. So the actual potential energy gain would be

$$\Delta U = \Delta U_{\text{ideal}} - U_{\text{loss due to friction}}$$

The same is true for an actual battery. There is some resistance in the battery, itself.

$$\Delta V = \Delta V_{\text{ideal}} - \Delta V_{\text{loss due to resistance}}$$

Now that we have Ohm's law, we can see what  $\Delta V_{\text{loss due to resistance}}$  would be in terms of the internal resistance of the battery and the current that flows. Referring to the last figure, there is only one way for the current to go. So for this circuit, the current must be the same throughout the entire circuit, even in the battery! If we call the small resistance in the battery  $r$ , then

$$\Delta V_{\text{loss due to resistance}} = Ir$$



and

$$\Delta V = \Delta V_{\text{ideal}} - Ir$$

It is traditional to give the ideal voltage a name and a symbol. We have encountered them before. This is the emf. At one time, the letters ‘e’, ‘m’, and ‘f’ stood for something. But not any more. It is just a name. It is pronounced “ē-em-ef,” and the symbol is a script capital  $\mathcal{E}$ .

When we first encountered emf we said it was essentially just the potential difference, but now we see that there is a difference. That difference is because of the internal resistance of the battery.

$$\Delta V = \mathcal{E} - Ir$$

Sometimes you will hear  $\mathcal{E}$  referred to as the voltage you would get if the battery is not connected (the “open circuit” voltage). This is the voltage marked on the battery. Notice that the actual voltage provided at the battery terminals depends on how much current is being drawn from the battery. So if you are draining your battery quickly (say, using your electric starter motor to start your car engine) the voltage supplied by your battery might drop (your lights might dim while the starter motor runs). You are not getting 12 V because the current  $I$  is large while the starter motor runs. We will change to this new symbol for ideal voltage. But we should keep in mind that actual voltages delivered may be significantly less than this ideal emf unless we plan our designs carefully.

### Circuits made from Resistors

Let’s try to use all we know about resistors and batteries to do a harder problem.

Determine the current in each branch of the circuit shown in the following figure.

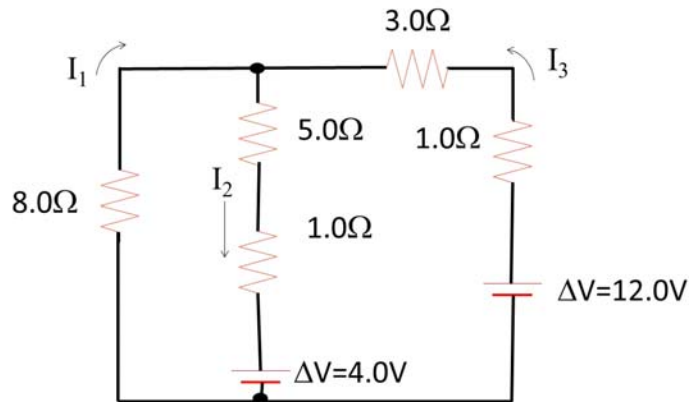

Note that I have labeled the currents  $I_1$ ,  $I_2$ , and  $I_3$  and I have given them directions. We have junctions now, so we can use the junction rule. I can write an equation using the top junction

$$0 = I_3 - I_2 - I_1 \quad (21.9)$$

Note that we have used all the currents we have, so we can stop with this one junction. The other junction at the bottom just gives

$$0 = -I_3 + I_2 + I_1$$

which gives the same equation. This is typical, usually we don't need all the junctions, but we do need to use enough junctions that every current shows up in an equation.

Now let's use the loop rule. Starting with the right most loop and going counter clock wise.

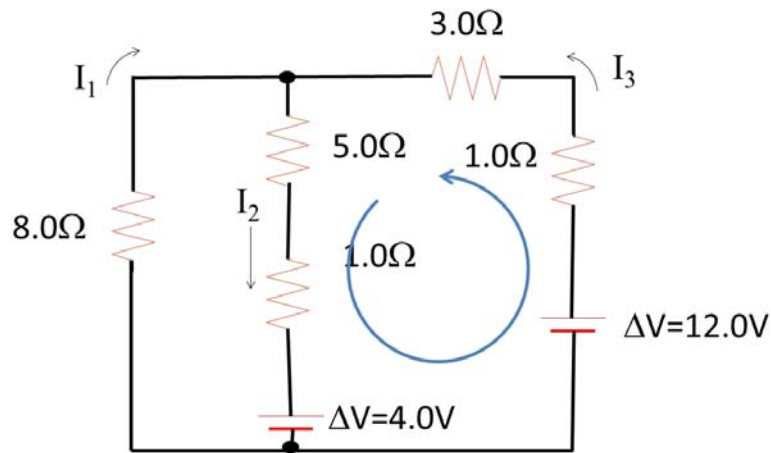

I will start with the battery. It will be  $+12\text{ V}$  because we are going from  $-$  to  $+$

$$12\text{ V} - I_3(1\ \Omega) - I_3(3\ \Omega) - I_2(5\ \Omega) - I_2(1\ \Omega) - 4\text{ V} = 0 \quad (21.10)$$

we can simplify this

$$8\text{ V} + I_3(-1\ \Omega - 3\ \Omega) + I_2(-5\ \Omega - 1\ \Omega) = 0 \quad (21.11)$$

$$8\text{ V} - I_3(4\ \Omega) - I_2(6\ \Omega) = 0 \quad (21.12)$$

$$8\text{ V} = I_3(4\ \Omega) + I_2(6\ \Omega) \quad (21.13)$$

$$4\text{ V} = I_3(2\ \Omega) + I_2(3\ \Omega) \quad (21.14)$$

Now lets take the left most loop, starting again with a battery

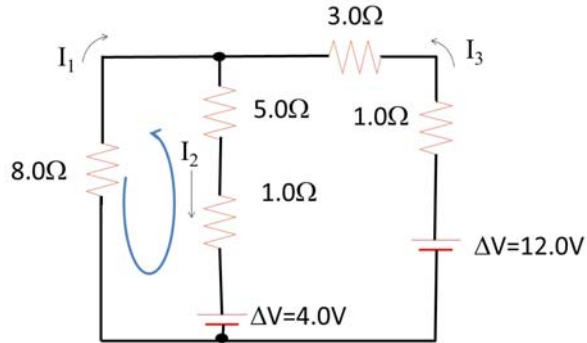

$$4\text{ V} + I_2 (1\ \Omega) + I_2 (5\ \Omega) - I_1 (8\ \Omega) = 0 \quad (21.15)$$

$$4\text{ V} + I_2 ((1\ \Omega) + (5\ \Omega)) - I_1 (8\ \Omega) = 0 \quad (21.16)$$

$$4\text{ V} + I_2 (6\ \Omega) - I_1 (8\ \Omega) = 0 \quad (21.17)$$

$$2\text{ V} + I_2 (3\ \Omega) - I_1 (4\ \Omega) = 0 \quad (21.18)$$

so we have three simplified equations to solve simultaneously.

$$0 = I_3 - I_2 - I_1$$

$$4\text{ V} = I_3 (2\ \Omega) + I_2 (3\ \Omega)$$

$$2\text{ V} + I_2 (3\ \Omega) - I_1 (4\ \Omega) = 0$$

Let's solve the first for  $I_3$

$$I_3 = I_2 + I_1$$

and substitute this into the second equation

$$4\text{ V} = (I_2 + I_1) (2\ \Omega) + I_2 (3\ \Omega)$$

$$4\text{ V} = I_2 (2\ \Omega) + I_1 (2\ \Omega) + I_2 (3\ \Omega)$$

$$4\text{ V} = I_1 (2\ \Omega) + I_2 (2\ \Omega) + I_2 (3\ \Omega)$$

$$4\text{ V} = I_1 (2\ \Omega) + I_2 (2\ \Omega + 3\ \Omega)$$

$$4\text{ V} = I_1 (2\ \Omega) + I_2 (5\ \Omega)$$

and solve for  $I_2$

$$4\text{ V} - I_1 (2\ \Omega) = +I_2 (5\ \Omega)$$

$$\frac{4\text{ V} - I_1 (2\ \Omega)}{(5\ \Omega)} = I_2$$

now substitute this into the third of our equations

$$2\text{ V} + \frac{4\text{ V} - I_1 (2\ \Omega)}{(5\ \Omega)} (3\ \Omega) - I_1 (4\ \Omega) = 0$$

and solve for  $I_1$

$$\begin{aligned}
 2V + 4V \frac{(3\Omega)}{(5\Omega)} - I_1 \frac{(2\Omega)(3\Omega)}{(5\Omega)} - I_1(4\Omega) &= 0 \\
 2V + 4V \frac{(3\Omega)}{(5\Omega)} - \left( I_1 \frac{(2\Omega)(3\Omega)}{(5\Omega)} + I_1(4\Omega) \right) &= 0 \\
 2V + 4V \frac{(3\Omega)}{(5\Omega)} - I_1 \left( \frac{(2\Omega)(3\Omega)}{(5\Omega)} + (4\Omega) \right) &= 0 \\
 2V + 4V \frac{(3\Omega)}{(5\Omega)} &= I_1 \left( \frac{(2\Omega)(3\Omega)}{(5\Omega)} + (4\Omega) \right) \\
 \frac{2V + 4V \frac{(3\Omega)}{(5\Omega)}}{\left( \frac{(2\Omega)(3\Omega)}{(5\Omega)} + (4\Omega) \right)} &= I_1
 \end{aligned}$$

$$I_1 = 0.846153846 \text{ A} \quad (21.19)$$

and now that we have  $I_1$  we go back an equation or two to find  $I_2$  terms of  $I_1$  and plug in our  $I_1$

$$\frac{4V - (0.846153846 \text{ A})(2\Omega)}{(5\Omega)} = I_2$$

$$I_2 = 0.461538462 \text{ A} \quad (21.20)$$

and again find our solution for  $I_3$  from the work we did above.

$$\begin{aligned}
 I_3 &= I_2 + I_1 \\
 &= 0.846153846 \text{ A} + 0.461538462 \text{ A} \\
 &= 1.30769231 \text{ A}
 \end{aligned}$$

It is a little bit long for a complicated circuit, but it is not really very hard.

ConceptTest 19.9 Wheetstone Bridge

ConceptTest 19.8

ConceptTest 19.10

## Resisters and Capacitors Together

Concept Question 18.1 - 18.3

Let's use our new *emf* notation to write the charge on a capacitor

$$Q = C\Delta V$$

or now, with an ideal battery,

$$Q = C\mathcal{E}$$

when the capacitor is fully charged (so  $I = 0$  and  $r$  does not matter).

Now consider what happens in the circuit shown below

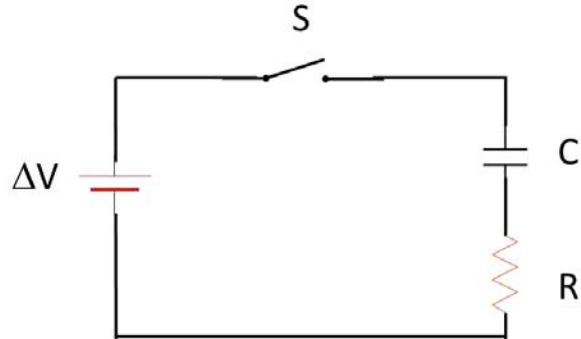

With the switch open, the capacitor is uncharged. So  $Q = 0$  before the switch is closed. It takes some time for current to start to flow after.

#### 10 F capacitor and bulb demo

We can see that if we let  $t = 0$  be the time the switch is closed, at  $t = 0$  we still have  $Q = 0$ . We will have a current of

$$I_o = \frac{\mathcal{E}}{R}$$

at this initial time.

We expect that at some later time,  $t_{long}$  we will have

$$Q = C\mathcal{E}$$

When this happens,  $\Delta V$  of the capacitor will be equal to  $\mathcal{E}$ . Since the potential is equal to the potential of the battery, the current must stop by  $t_{long}$ . It would be good to be able to calculate what happens between  $t = 0$  and  $t = t_{long}$ .

## RC charge as function of time

We can do this using Kirchhoff's loop rule.

$$\Delta V_{battery} - \Delta V_C - \Delta V_R = 0$$

or

$$\mathcal{E} - \frac{q}{C} - IR = 0$$

and we know that the current  $I = dq/dt$  so

$$\mathcal{E} - \frac{q}{C} - \frac{dq}{dt}R = 0$$

rearranging gives

$$\frac{\mathcal{E}}{R} - \frac{q}{RC} = \frac{dq}{dt}$$

which is a wonderful differential equation—one we can solve. We separate the variables  $dq$  and  $dt$

$$\frac{C\mathcal{E} - q}{RC} = \frac{dq}{dt}$$

then

$$dt = \frac{dq}{\frac{C\mathcal{E} - q}{RC}}$$

$$\frac{dt}{RC} = \frac{dq}{C\mathcal{E} - q}$$

and we integrate both sides

$$\frac{1}{RC} \int_0^t dt' = \int_0^q \frac{1}{C\mathcal{E} - q'} dq'$$

or

$$\frac{t}{RC} = \int_0^q \frac{1}{C\mathcal{E} - q'} dq'$$

now we let  $u = C\mathcal{E} - q$  so  $du = -dq$  and our limits of  $q' = 0$  gives  $u = C\mathcal{E}$  and the limit of  $q' = q$  gives  $u = C\mathcal{E} - q$

$$\begin{aligned} \frac{t}{RC} &= - \int_{C\mathcal{E}}^{C\mathcal{E} - q} \frac{1}{u} du \\ &= - \ln u \Big|_{C\mathcal{E}}^{C\mathcal{E} - q} \\ &= - (\ln(C\mathcal{E} - q) - \ln(C\mathcal{E})) \\ &= - \ln \left( \frac{C\mathcal{E} - q}{C\mathcal{E}} \right) \end{aligned}$$

then

$$\frac{t}{RC} = - \ln \left( \frac{C\mathcal{E} - q}{C\mathcal{E}} \right)$$

Exponentiating both sides gives

$$\begin{aligned} e^{-\frac{t}{RC}} &= \left( \frac{C\mathcal{E} - q}{C\mathcal{E}} \right) \\ e^{-\frac{t}{RC}} &= 1 - \frac{q}{C\mathcal{E}} \\ e^{-\frac{t}{RC}} &= 1 - \frac{q}{C\mathcal{E}} \\ e^{-\frac{t}{RC}} - 1 &= -\frac{q}{C\mathcal{E}} \\ C\mathcal{E} \left( 1 - e^{-\frac{t}{RC}} \right) &= q \end{aligned}$$

and now we recognize that

$$Q = C\Delta V = C\mathcal{E}$$

as the total charge that the capacitor can hold, then

$$q(t) = Q \left(1 - e^{-\frac{t}{RC}}\right) \quad (21.21)$$

## RC example

The small  $q$  is the charge it has at the current time. This will get bigger until at  $t_{long}$  it will reach  $Q$ . The letter  $e$  here is the base of the natural logarithm. Suppose we had the following values

$$\begin{aligned} R &= 2\ \Omega \\ C &= 10\ \text{F} \\ \mathcal{E} &= 1.5\ \text{V} \end{aligned} \quad (21.22)$$

then our charge as a function of time would be

$$q(t) = (10\ \text{F})(1.5\ \text{V}) \left(1 - e^{-\frac{t}{(2\ \Omega)(10\ \text{F})}}\right) \quad (21.23)$$

We can plot this

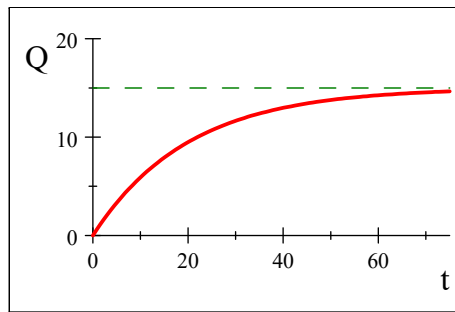

notice, that by about  $t = 70$  s we essentially have  $q = Q$ . But up to that point, the charge changes in a very non-linear way. The part of the equation that looks like

$$\left(1 - e^{-\frac{t}{RC}}\right)$$

is interesting, what is  $e^0$ ?

$$e^0 = 1$$

so at  $t = 0$  we do have  $q = 0$  because

$$\left(1 - e^{-\frac{t}{RC}}\right) = (1 - 1)$$

For any positive time,  $e^{-\frac{t}{RC}}$  will be less than 1. For large times  $\frac{t}{RC}$  gets to be a big number. So  $e^{-\frac{t}{RC}}$  gets very small, So  $\left(1 - e^{-\frac{t}{RC}}\right)$  gets very close to 1. That means that

$$q = Q \left(1 - e^{-\frac{t}{RC}}\right) \rightarrow Q(1) = Q$$

just as we saw in the graph and as we know it must.

We sometimes give a name to  $R \times C$

$$\tau = RC \quad (21.24)$$

this is called the *time constant* because it tells us something about how long it takes for  $q$  to go from 0 to get to  $Q$ . The “t-looking-thing” is a Greek letter “τ” It is pronounced “tau.” Note that we also use  $\tau$  for torque, but this is really not torque. It is an amount of time.

## RC Current

We can also find the current. We know that

$$I = \frac{dq}{dt} = \frac{d}{dt}Q \left(1 - e^{-\frac{t}{RC}}\right) = -Q \frac{d}{dt}e^{-\frac{t}{RC}} = \frac{Q}{RC}e^{-\frac{t}{RC}}$$

but from  $Q = C\mathcal{E}$  we have

$$\begin{aligned} I(t) &= \frac{\mathcal{E}}{R}e^{-\frac{t}{RC}} \\ &= I_o e^{-\frac{t}{RC}} \end{aligned}$$

where  $I_o$  is the maximum current  $I_{\max} = \mathcal{E}/R$ . For our case this looks like

$$I(t) = 0.75 \text{ A} e^{-\frac{t}{20 \text{ s}}}$$

## RC Discharging

To understand better what the time constant means, lets now remove the battery from the circuit, but let the circuit stay connected (say, replace the battery with a piece of wire). Now we find that the charge seems to fade away!

10 F capacitor and bulb demo

We can calculate what the charge would be as a function of time. We probably won't have time to do this in class, but really it is just the same the answer is

$$q = Qe^{-\frac{t}{RC}} = Qe^{-\frac{t}{\tau}} \quad (21.25)$$

We find by again taking Kirchhoffs rule

$$\Delta V_{bat} - \Delta V_C - \Delta V_R = 0$$

or

$$0 - \frac{q}{C} - IR = 0$$



Again writing out the current gives

$$\frac{q}{RC} = -\frac{dq}{dt}$$

$$\frac{dt}{RC} = -\frac{dq}{q}$$

and integrating gives

$$-\frac{1}{RC} \int_0^t dt' = \int_Q^q \frac{dq'}{q'}$$

so

$$-\frac{t}{RC} = \ln\left(\frac{q}{Q}\right)$$

and exponentiating both sides gives

$$q = Qe^{-\frac{t}{RC}} = Qe^{-\frac{t}{\tau}} \quad (21.26)$$

Now we can see that if  $t = \tau$ , then

$$q = Qe^{-\frac{\tau}{RC}} = Qe^{-1} = Qe^{-1}$$

since  $e = 2.7183$ ,

$$e^{-1} = \frac{1}{e} = 0.36788$$

so we have

$$q = 0.36788Q$$

That is, after a time  $\tau$ , we are at about 37% of the original charge, or we have *lost* about 63% of the original charge. Likewise, if we decide to recharge our capacitor,  $\tau$  will tell us how long it takes to gain 63% of the full charge.

We can say a capacitor *discharges* when it loses its charge. Let's plot the discharge.

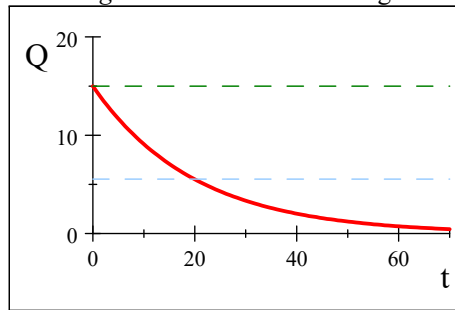

As we would expect, by about  $t = 50$  s, we have discharged. At  $\tau = 10$  s we have about 37% of the full charge (3 C in this case).

---

The observant student might worry that our equation gives values for very large values of  $t$ . Does the capacitor ever fully discharge? Well, yes it does. Remember that we have a minimum charge of  $1.6 \times 10^{-19}$  C because that is the charge of our charge carrier. We can't have less charge than that. So when our equation gives  $q < 1.6 \times 10^{-19}$  C, we will remember that it must really be  $q = 0$ .

---

Concept Question 18.4

## Meters

### Ammeters

Suppose we wanted to know how much water flowed through our pipes in our water system.

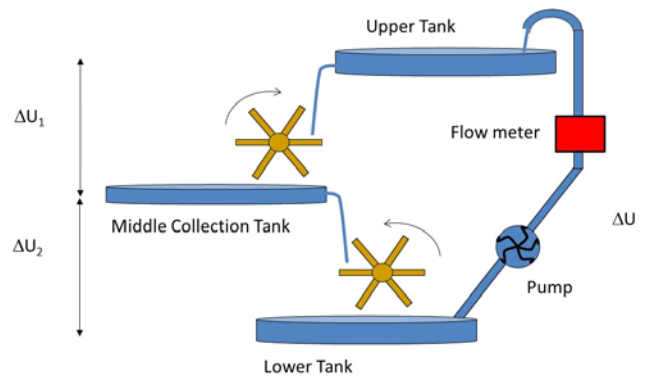

To do this we install a flow meter. The flow meter has to have the water flow through it in order to tell how much water has gone by.

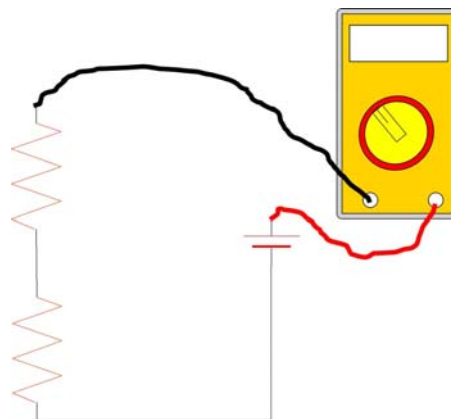

The same is true for measuring current. The meter must be *in the circuit* to measure the current because the current has to go through the meter to be measured. The meter that measures current is called an ammeter, and ideally the ammeter will not have any resistance. You might guess that this is hard to achieve. In practice, well, in the circuit above we have an ammeter measuring the current through two resistors. The current should be

$$I = \frac{\mathcal{E}}{R_1 + R_2} \quad (21.27)$$

but we know that there must be some resistance from the ammeter, so

$$I = \frac{\mathcal{E}}{R_1 + R_2 + R_a} \quad (21.28)$$

where  $R_a$  is the resistance due to the ammeter. Suppose all three resistances are the same, then with no ammeter we would have

$$I = \frac{\mathcal{E}}{2R} \quad (21.29)$$

but with the ammeter

$$I' = \frac{\mathcal{E}}{3R} \quad (21.30)$$

which gives a percent change of

$$\frac{I - I'}{I'} = \frac{\frac{\mathcal{E}}{2R} - \frac{\mathcal{E}}{3R}}{\frac{\mathcal{E}}{3R}} = 0.5 \quad (21.31)$$

or on the order of 50%! Usually  $R_a$  is designed to be very small, but you need to know your meter to know how much to trust it when you seek to measure circuits with low resistance.

## Voltmeters

Suppose we wanted to know how much potential energy is lost when the water moves from the middle tank to the lower tank. What would we do?

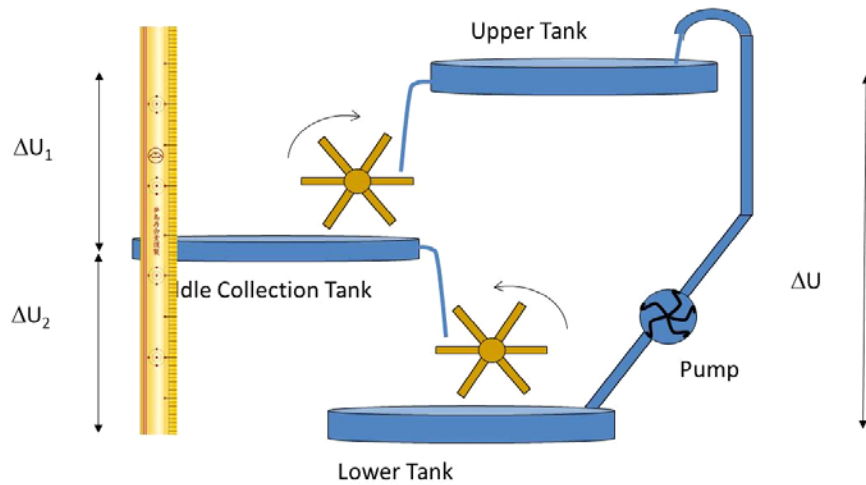

Well, I think we would measure the distance from the lower tank to the middle tank, and then multiply by  $mg$ . The potential would be

$$\Delta U = mg(y_2 - y_1)$$

Notice that to measure potential energy we have to make *two* measurements, one at  $y_1$  and one at  $y_2$ . This is always true for a potential energy *difference*. The same is true for electric potential. But we don't use a ruler to measure electric potential. We use a volt meter.

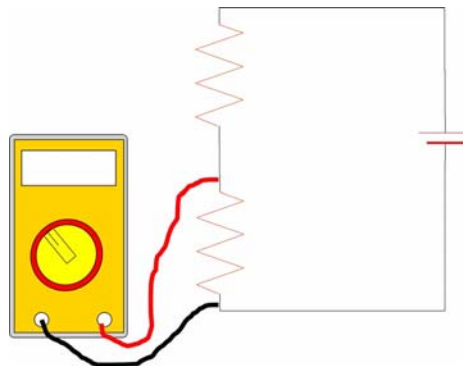

Notice that to measure the voltage drop for the lower resistor we need two measurements on either side of the resistor.

Really the meter measures a small current flowing through a very large resistor inside the meter. Ideally, a voltmeter would have infinite resistance. Of course it is difficult to

achieve an infinite resistance, so we have to make due with smaller, finite, resistances. We can see that if  $R_V$  of the voltmeter is not much larger than  $R_2$ , then it will change the current through  $R_2$ . Since

$$\Delta V = RI \quad (21.32)$$

the current should be

$$\Delta V = R_2 I \quad (21.33)$$

were we can find  $I$

$$I = \frac{\mathcal{E}}{R_1 + R_2} \quad (21.34)$$

but suppose the voltmeter has a resistance equal to  $R_2$ . Then, from the loop rule,

$$I = I_2 + I_V \quad (21.35)$$

where  $I_2$  will go through  $R_2$  and  $I_V$  will go through the voltmeter. Since the resistances are the same, we expect  $I_2 = I_V$ . so now

$$I_2 = \frac{I}{2} \quad (21.36)$$

Then

$$\Delta V = R_2 I_2 = \frac{IR_2}{2} \quad (21.37)$$

or half the value we expected!

A too-small resistance will change the voltage it is trying to measure. Again, you must know your meter before you attempt to make the measurement across elements with large resistances.

## Household Circuits

Many of you may have worked on new homes and may understand household wiring quite well. I am just going to give a high level overview.

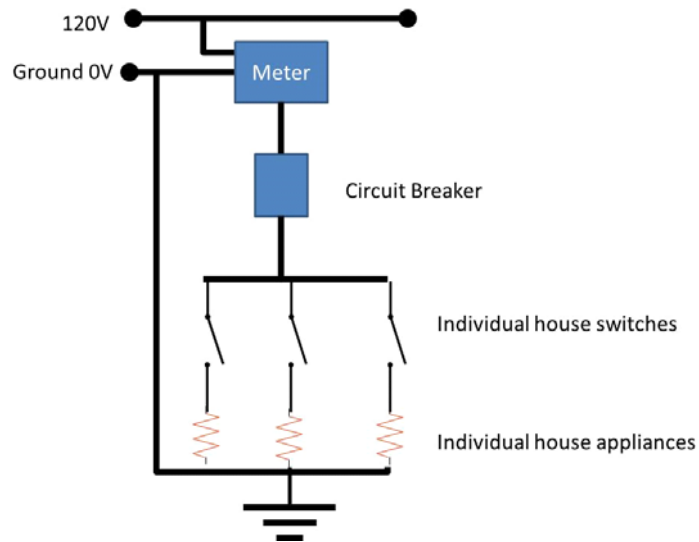

Electrical power enters our homes through a meter (so the power company can charge us) and is divided into several major circuits. Each circuit is designed according to what is likely to be done in the room it services. Bedrooms likely will require less power than kitchens, for example. Each circuit has a *circuit breaker*. This device senses when too much current is flowing and stops the flow to the entire circuit before wires can heat and pose a danger.

Usually only one of the wires entering the home carries current. We call this the *live wire*. The other is neutral and represents our home zero potential point. For larger appliances, we often will have a third wire that represents a large negative potential as well.

In modern electrical outlets, there are also three wires. One is called the *ground* wire. The chassis of many electrical devices are connected to this ground wire. If there is a malfunction such that the live wire is accidentally connected to the device, the electrical current is more likely to travel through the ground wire. This is good because relatively small currents ( $<100\text{ mA}$ ) can be fatal!

# 22 Magnetism

## Fundamental Concepts

- The Earth has a magnetic field
- Magnets have “magnetic charge centers” called poles and there is a magnetic field.
- Magnetic poles don’t seem to exist independently
- A long wire that carries a current produces a magnetic field
- The magnetic field due to a long wire with current becomes weaker with distance and forms concentric cylinders of constant magnetic field strength
- The direction of the long-wire-with-current field is given by a right-hand-rule.
- The field due to a moving charge is given by the *Biot-Savart law*

$$B = \frac{\mu_o}{4\pi} \frac{qv \sin \theta}{r^2}$$

Most people have used a magnet. at some time. They come as ads that stick to a refrigerator. They are the working part of a compass. They hold the pieces of travel games to their boards, etc. So I think we all know that magnets stick to metal things. But do they stick to all metal things?

The answer is no, only a few metals work. Iron and Nickel and Cobalt are some that do. Aluminum and Copper do not. By the time we are done studying magnetism, we should be able to explain this.

Magnets are very like charged objects in some ways. They can attract or repel each other They attract “unmagnetized” materials. But there are some important differences.

Bar Magnet Demo –  
Make this like the  
first charge demo

Bar Magnet Demo  
– Alternate, use the  
array of iron ar-  
rows and an over-  
head projector with  
the bar magnet

Notice that a “magnetic charge” seems to be induced in some metal objects, but not in other common objects. This is very different than electric charge and electric polarization! And we should state explicitly that for magnets, there seem to be both “charges” in the same object! We call the “charge centers” the *poles* of the magnet. We find that one pole attracts one of the poles of a second magnet and repels the other.

More Bar Magnet Demo – Like Poles

If we turn around the first magnet, we find that our pattern of attraction and repulsion reverses. Because magnets were used for centuries in navigational compasses, we call one pole the *north pole* of the compass and the other the *south pole* of the magnet. The north pole is the pole that would orient toward the north. Why does this happen?

I hope your high school science class taught you that the Earth has a magnetic field.

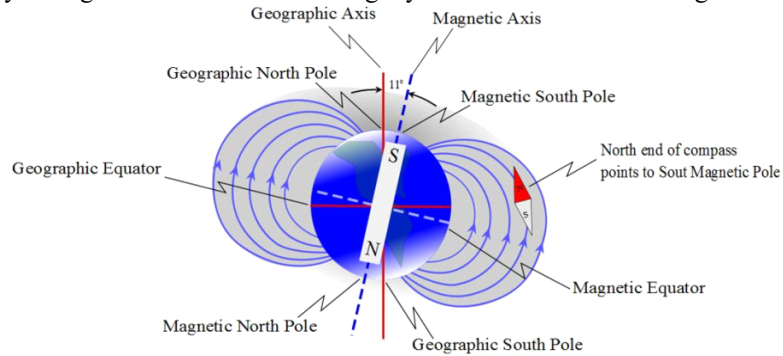

So we constantly live under the influence of a large magnet! Now lets hang both of our magnets from a string, and see which way they like to hang. The north facing end we will label *N* and the south facing end we will label *S*. Now we can see that the two *N* ends repel each other and the two *S* ends repel each other. But a *N* end and a *S* end will attract.

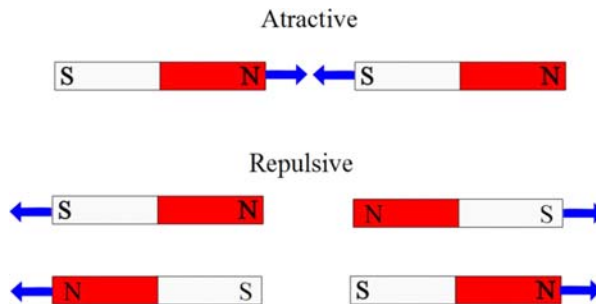

Once again we have a situation where we can define a mover object and an environmental object. We can picture one of the magnets making a magnetic field and the other magnet moving through this field. Of course both magnets make magnetic fields, but since a magnet can't make a magnetic field that moves itself, we won't draw this self-field for the mover magnet. We just draw the field for the environmental magnet. We did this in our Earth-compass picture. The Earth was the environmental magnet and the compass was the mover magnet.

One quirk of history is that since a *N* end of a magnet is attracted to the North part of



the Earth. But north end of magnets are attracted to south poles of magnets, the Earth's geographic north pole must be a magnetic south pole!

One common misconception is that there is one specific place that is the magnetic north pole. Really it is a region near Newfoundland where the field strength actually varies quite a bit. You may have heard people discuss how the poles switch every so often. This is true, and we don't fully understand the mechanism for this.

There is a large difference between the magnetic force and the electric force. Electric charges are easy to separate. But magnetic poles are not at all easy to separate. If we break a magnet

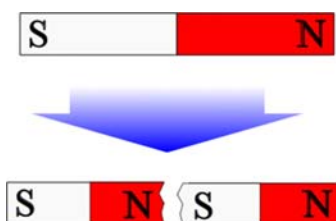

we end up with each piece being a magnet complete with both north and south ends. This is very mysterious! something about the source of the magnetic field must be very different than for the source of the electric field. We will investigate the source of a magnetic field as we go.

The Earth's magnetic fields affects many biological systems. One of these is a bacteria that contain small permanent magnets inside of them to help them find the mud they live in.

In the 1990's there was a health fad involving magnets. Many people bought magnets to strap on their bodies. They were supposed to reduce aging and give energy. Mostly they stimulated the economy. But we will find that magnetic fields can alter the flow of blood (but these magnets did not do so, the FDA would not allow strong enough magnets to be sold as apparel to have this effect). Another common place to find magnetic fields is the MRI devices used in hospitals to make images of the interior of bodies.

Question 223.37.6

Pass out magnets on sticks

Pass out magnets

We have now experience with two non-contact forces, the gravitational force and the electric or Coulomb force. In both cases, we have found that there is a field involved with the production of this force. We can guess that this is true for the magnetic force as well.

The discovery of this field involved an accidental experiment, and understanding this experiment gives us great insight into the nature of this field and where it comes from.

So we will spend a little time describing it.

### Discovery of Magnetic Field

Question 223.38.1

In 1819 a Dutch scientist named Oersted was lecturing on electricity. He was actually making the point that there was no connection between electricity and magnetism. He had a large battery connected to a wire. A large current flowed through the wire. By chance, Oersted placed a compass near the wire. He had done this before, but this time the wire was in a different orientation than in previous demonstrations. To his great surprise, the compass needle changed direction when it was placed near the wire!

A similar experiment, but this time with several compasses, is shown in the next figure.

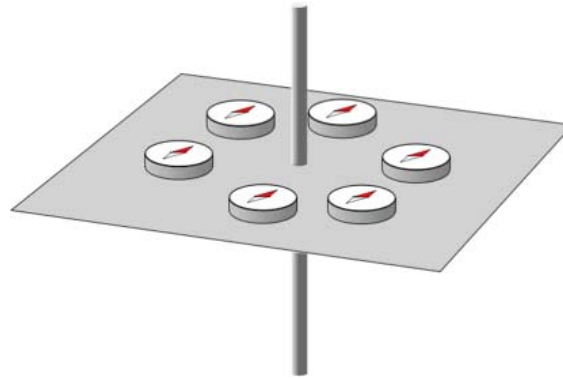

When the current is turned on, the compasses change direction.

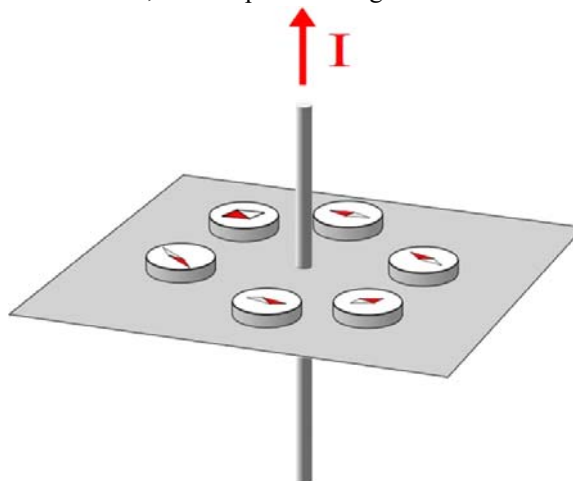

This is a very good clue that there really *is* a connection between electricity and

Oersted's Experiment Demo: Use the 106 boards and compasses

magnetism.

We know that a compass orients itself in the Earth's magnetic field. We can infer that the compass needle will orient in any magnetic field. In the next figure you can see that there is a force on each end of the needle due to the magnetic field.

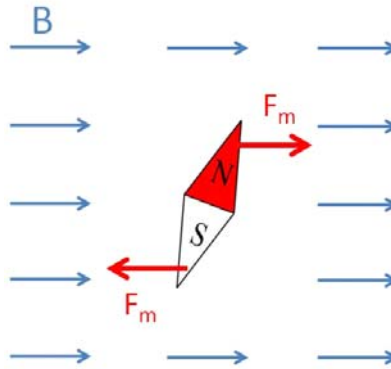

Notice that we have marked the environmental magnetic field with the letter  $B$ . This is traditional. Magnetic fields are often called  $B$ -fields for this reason. But more importantly, this looks very like an electric dipole in a constant electric field. We know enough about the dipole situation to predict that there will be a torque, and that there will be a stable equilibrium when the compass needle is aligned with the magnetic field.

Since our compasses oriented themselves near the current carrying wire, there must be a magnetic field caused by the current in the wire. The field shown in the last figure is uniform, but the field of our wire cannot be uniform. The compasses pointed different directions. A common way to describe this field is with a right-hand-rule. We imagine grabbing the wire with our right hand with our thumb pointing in the current direction. The field direction is given by our fingers.

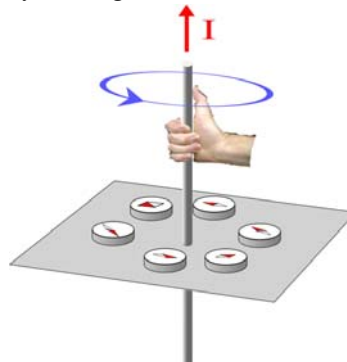

Question 223.38.2

Although this is true, it takes some interpretation. Let's take some time to see what it means. Let's redraw the figure.

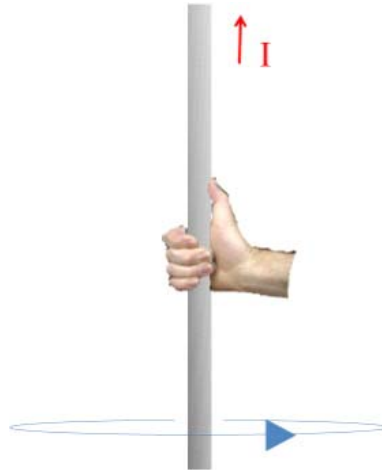

Now that we have a new figure, let's reconsider what our right-hand rule. What we mean is that the magnetic field is constant in magnitude around a circle, and that the direction of the field is tangent to the circle, with the arrow pointing in the direction your fingers go with the right-hand-rule.

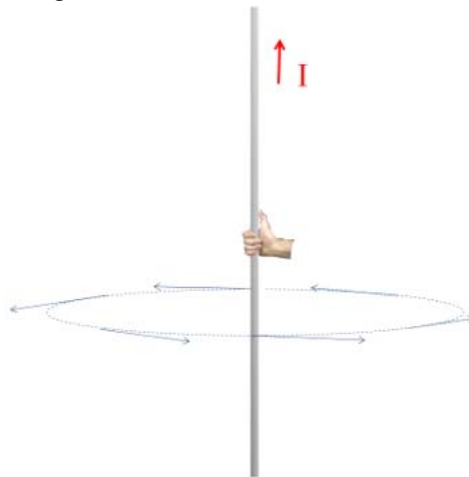

This is easier to see in a top-down view.

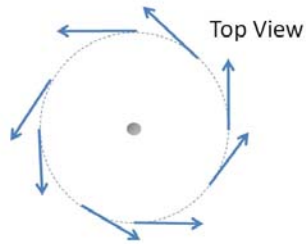

But in the first figure we only drew the field around one circle. By using symmetry, we can guess that the field magnitude must be constant around any circle. It must depend only on  $r$ , if the current is constant. So we could draw constant field lines at any distance,  $r$ , away from the wire.

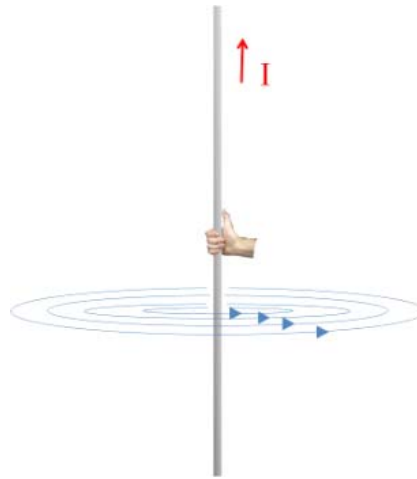

Question 223.38.3

But again, this figure is not so good, because the entire wire makes a field that has a constant value for  $B$  at a distance  $r$  away. So we could also draw the field above our hand.

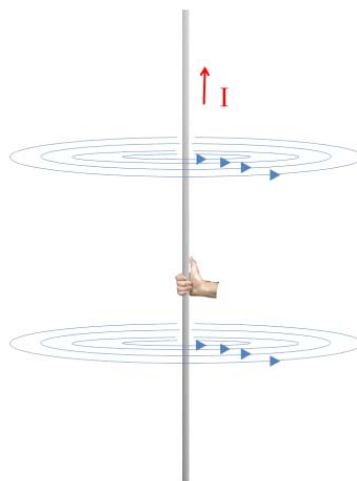

Maybe a better way to draw this field would be a set of concentric cylinders. Along the surface of the cylinder (but not the end caps) the field will be constant.

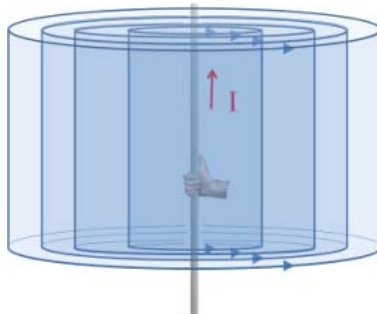

Of course, if our wire is infinitely long, the cylinders will be infinitely long too...

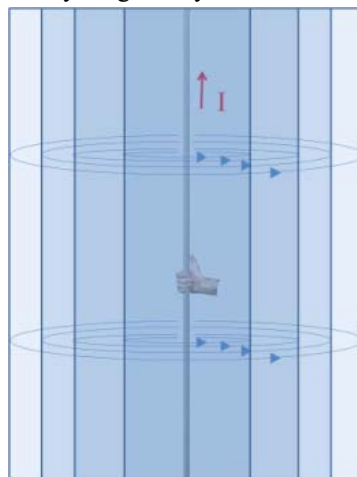

Question 223.38.4

And the field does not stop after a few cylinders, it reaches  $B = 0$  only when  $r = \infty$ . So the field fills all of space.

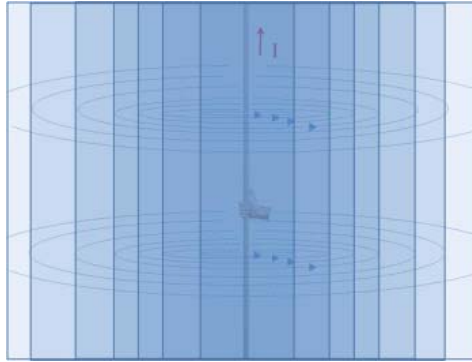

This is a more accurate way to draw the magnetic field due to a long straight wire, but it takes a long time to draw such a diagram, so usually we will just draw one circle, and you will have to mentally fill in the other circles and the concentric cylinders that they represent.

To use the right hand rule, remember to place your thumb in the current direction. Then the field direction is given tangent to the circle and pointing in our finger direction.

## Making the field—moving charges

But how does a current in a wire make a magnetic field?

The secret is to look at the individual charges that are moving. When early scientists caused individual charges to move, they found they created magnetic fields. The experimental results gave a relationship for the strength of this field

$$B = \frac{\mu_o}{4\pi} \frac{qv \sin \theta}{r^2}$$

and the direction is given by the right hand rule by pointing the thumb in the direction the charges are going and using the fingers to indicate the field direction as we have described above. In a sense, this is a very small current (one moving charge!). So the field should look very similar.

This relationship was found by two scientists, Biot and Savart, and it carries their name, the *Biot-Savart law*.

The factor  $\mu_o$  is a constant very like  $\epsilon_o$ . It has a value

$$\mu_o = 4\pi \times 10^{-7} \frac{\text{T m}}{\text{A}}$$

and is called the *permeability of free space*. The unit T is called a *tesla* and is

$$\text{T} = \frac{\text{N}}{\text{A m}}$$

The charges already had an electric field before they were accelerated, but now they have two fields, an electric and a magnetic field.

We used unit vectors to write our  $E$ -field.

$$\vec{\mathbf{E}} = \frac{1}{4\pi\epsilon_0} \frac{q}{r^2} \hat{\mathbf{r}}$$

It is convenient to do the same for the magnetic case. We can remember that a vector cross product is given by

$$\vec{\mathbf{a}} \times \vec{\mathbf{b}} = ab \sin \theta \quad \perp \vec{\mathbf{a}}, \perp \vec{\mathbf{b}}$$

where the resulting vector is perpendicular to both  $\vec{\mathbf{a}}$  and  $\vec{\mathbf{b}}$ . Thinking about this for a while allows us to realize this is just what we want for the magnetic field. If the velocity of the charges is up (say, in the  $\hat{\mathbf{z}}$  direction) then we can use our right hand rule to realize we need a vector perpendicular to both  $\hat{\mathbf{z}}$  and  $\hat{\mathbf{r}}$ . This is given by

$$\hat{\mathbf{z}} \times \hat{\mathbf{r}}$$

which is always tangent to the circle indicated by our fingers. Since  $v$  is in the  $z$  direction we can use

$$\vec{\mathbf{v}} \times \hat{\mathbf{r}} = v \sin \theta \quad \perp \vec{\mathbf{v}}, \perp \hat{\mathbf{r}}$$

to write the Biot-Savart law as

$$\vec{\mathbf{B}} = \frac{\mu_0}{4\pi} \frac{q \vec{\mathbf{v}} \times \hat{\mathbf{r}}}{r^2}$$

We should do a problem to see how this works.

Suppose we accelerate a proton and send it in the  $z$ -direction to a speed of  $1.0 \times 10^7$  m/s. Let's further suppose we have a magnetic field detector placed 1 mm from the path of the proton. What field would it measure?

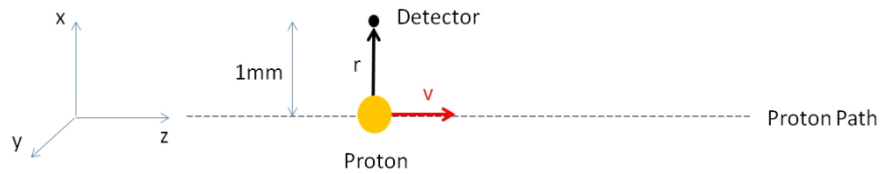

We know

$$\vec{\mathbf{B}} = \frac{\mu_0}{4\pi} \frac{q \vec{\mathbf{v}} \times \hat{\mathbf{r}}}{r^2}$$

and by symmetry we know that  $v$  is perpendicular to  $\hat{\mathbf{r}}$  just as the proton passes the detector. So, using the right hand rule for cross products, we put our hand in the  $v$ -direction and bend our fingers into the  $r$ -direction. Then our thumb shows the



resulting direction. In this case it is in the positive  $y$ -direction, or out of the page. The magnitude would be

$$\begin{aligned}\vec{\mathbf{B}} &= \frac{4\pi \times 10^{-7} \frac{\text{T}\cdot\text{m}}{\text{A}}}{4\pi} \frac{(1.6 \times 10^{-19} \text{ C}) (1.0 \times 10^7 \text{ m/s})}{(0.001 \text{ m})^2} \hat{\mathbf{y}} \\ &= 1.6 \times 10^{-13} \text{ T} \hat{\mathbf{y}}\end{aligned}$$



# 23 Current loops

## Fundamental Concepts

- The magnetic field due to a current in a wire is given by the integral form of the Biot-Savart law  $\vec{B} = \frac{\mu_0 I}{4\pi} \int \frac{d\vec{s} \times \hat{r}}{r^2}$
- The magnetic field magnitude of a long straight wire with a current is given by  $B = \frac{\mu_0 I}{2\pi a}$  with the direction given by the right hand rule we learned last time.
- The field due to a magnetic dipole is  $\vec{B} \approx \frac{\mu_0}{4\pi} \frac{2\vec{\mu}}{r^3} \hat{r}$  where  $\vec{\mu}$  is the magnetic dipole moment  $\mu = IA$  with the direction from south to north pole.

## Magnetic field of a current

Last lecture, we learned the Biot-Savart law

$$\vec{B} = \frac{\mu_0}{4\pi} \frac{q \vec{v} \times \hat{r}}{r^2}$$

now let's consider our  $q$  to be part of a current in a wire. A small amount of current moves along the wire. Let's call this small amount of charge  $\Delta Q$ .

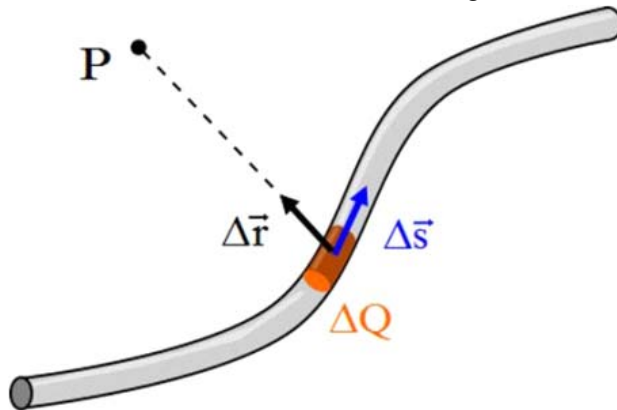

This small amount of charge will make a magnetic field, but it will be only a small part of the total field, because  $\Delta Q$  is only a small part of the total amount of charge flowing

in the wire. That part of the field made by  $\Delta Q$  is

$$\Delta \vec{\mathbf{B}} = \frac{\mu_o}{4\pi} \frac{\Delta Q \vec{\mathbf{v}} \times \hat{\mathbf{r}}}{r^2}$$

Let's look at  $\Delta Q \vec{\mathbf{v}}$ . We can rewrite this as

$$\begin{aligned} \Delta Q \vec{\mathbf{v}} &= \Delta Q \frac{\Delta \vec{\mathbf{s}}}{\Delta t} \\ &= \frac{\Delta Q}{\Delta t} \Delta \vec{\mathbf{s}} \\ &= I \Delta \vec{\mathbf{s}} \end{aligned}$$

then our small amount of field is given by

$$\Delta \vec{\mathbf{B}} = \frac{\mu_o}{4\pi} \frac{I \Delta \vec{\mathbf{s}} \times \hat{\mathbf{r}}}{r^2}$$

as usual, where there is a  $\Delta$ , we can predict that we can take a limit and end up with a  $d$

$$d\vec{\mathbf{B}} = \frac{\mu_o}{4\pi} \frac{I d\vec{\mathbf{s}} \times \hat{\mathbf{r}}}{r^2}$$

Question 223.39.1

Some things to note about this result

1. The vector  $d\vec{\mathbf{B}}$  is perpendicular to  $d\vec{\mathbf{s}}$  and to the unit vector  $\hat{\mathbf{r}}$  directed from  $d\vec{\mathbf{s}}$  to some point  $P$ .

Question 223.39.2

2. The magnitude of  $d\vec{\mathbf{B}}$  is inversely proportional to  $r^2$

Question 223.39.3

3. The magnitude of  $d\vec{\mathbf{B}}$  is proportional to the current

Question 223.39.4

4. The magnitude of  $d\vec{\mathbf{B}}$  is proportional to the length of  $d\vec{\mathbf{s}}$

Question 223.39.5

5. The magnitude of  $d\vec{\mathbf{B}}$  is proportional to  $\sin \theta$  where  $\theta$  is the angle between  $d\vec{\mathbf{s}}$  and  $\hat{\mathbf{r}}$

Where there is  $d\vec{\mathbf{B}}$  we will surely integrate. The field  $d\vec{\mathbf{B}}$  is due to just a small part of the wire  $d\vec{\mathbf{s}}$ . We would like the field due to all of the wire. So we take

$$\vec{\mathbf{B}} = \frac{\mu_o I}{4\pi} \int \frac{d\vec{\mathbf{s}} \times \hat{\mathbf{r}}}{r^2}$$

This is a case where the equation actually is as hard to deal with as it looks. The integration over a cross product is tricky. Let's do an example.

## The field due to a square current loop

Suppose we have a square current loop. Of course there would have to be a battery or some potential source in the loop to make the current, but we will just draw the loop with a current as shown. The current must be the same in all parts of the loop.

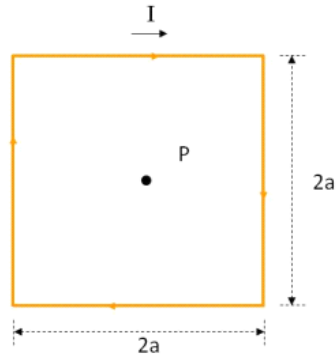

Let's find the field in the center of the loop at point  $P$ .

I will break up the integration into four parts, one for each side of the loop. For each part, we will need to find  $d\vec{s} \times \hat{r}$  and  $r$  to find the field using

$$\vec{B} = \frac{\mu_o I}{4\pi} \int \frac{d\vec{s} \times \hat{r}}{r^2}$$

This is very like what we did to find electric fields. For electric fields we had to find  $dq$ ,  $\hat{r}$ , and  $r$  and we integrated using

$$\vec{E} = \frac{1}{4\pi\epsilon_o} \int \frac{dq}{r^2} \hat{r}$$

Now we need  $d\vec{s} \times \hat{r}$  and  $r$ . For electric fields, we needed to deal with the vector  $\hat{r}$ .

Now we need to deal with a cross product,  $d\vec{s} \times \hat{r}$ , involving  $\hat{r}$ .

For the bottom part of our loop  $d\vec{s} \times \hat{r}$  is just

$$\begin{aligned} d\vec{s} \times \hat{r} &= -ds \sin \theta \hat{k} \\ &= -dx \sin \theta \hat{k} \end{aligned}$$

We can see this in the figure

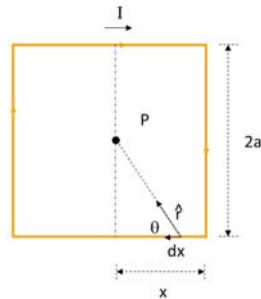

so our field from the bottom wire is

$$\begin{aligned}\vec{\mathbf{B}}_b &= \frac{\mu_o I}{4\pi} \int \frac{d\vec{\mathbf{s}} \times \hat{\mathbf{r}}}{r^2} \\ &= \frac{\mu_o I}{4\pi} \int \frac{-dx \sin \theta \hat{\mathbf{k}}}{r^2}\end{aligned}$$

But we need to find  $r$ . From trigonometry we realize

$$\sin \theta = \frac{a}{r}$$

on the right side of the wire, and

$$\sin(\pi - \theta) = \sin \theta = \frac{a}{r}$$

on the left, thus

$$r = \frac{a}{\sin \theta}$$

then our field equation for the bottom wire becomes

$$\vec{\mathbf{B}}_b = \frac{\mu_o I}{4\pi} \int \frac{-(dx) \sin \theta \hat{\mathbf{k}}}{\left(\frac{a}{\sin \theta}\right)^2}$$

but now we have an integration over  $dx$  and our function is in terms of  $\theta$  which depends on  $x$ . We should try to fix this. Let's find  $dx$  in terms of  $d\theta$ . We can pick  $x = 0$  to be the middle of the wire. Then

$$\tan \theta = \frac{a}{x}$$

on the right and

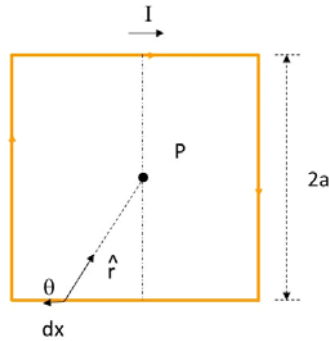

$$\tan(\pi - \theta) = -\tan \theta = \frac{a}{x}$$

on the left. Since on the left  $x$  is negative, this makes sense. So we have either

$$x = \frac{a}{\tan \theta}$$

or

$$x = -\frac{a}{\tan \theta}$$

depending on which side of the dotted line we are on. We could write these as

$$x = \pm \frac{a}{\tan \theta} = \pm \frac{a \cos \theta}{\sin \theta}$$

for both cases. We really want  $dx$  and moreover we want it as a magnitude (we deal with the direction in the cross product). So we can take a derivative and then take the magnitude (absolute value).

$$\frac{dx}{d\theta} = \frac{\sin \theta (-a \sin \theta) - a \cos \theta \cos \theta}{\sin^2 \theta} = \frac{-a}{\sin^2 \theta}$$

This derivative was not obvious! We had to use the quotient rule. But once we have found it we can rewrite this as

$$dx = \left| \frac{-a}{\sin^2 \theta} d\theta \right|$$

(now with the absolute value inserted) and since neither  $a$  nor  $\sin^2 \theta$  can be negative we can just write this as

$$dx = \frac{a}{\sin^2 \theta} d\theta$$

Then our field for the bottom wire is

$$\vec{\mathbf{B}}_b = \frac{\mu_o I}{4\pi} \int \frac{-\left(\frac{a}{\sin^2 \theta}\right) d\theta \sin \theta \hat{\mathbf{k}}}{\left(\frac{a}{\sin \theta}\right)^2}$$

which we should simplify before we try to integrate.

$$\begin{aligned} \vec{\mathbf{B}}_b &= \frac{\mu_o I}{4\pi} \int \frac{-\sin \theta d\theta \hat{\mathbf{k}}}{a} \\ &= -\frac{\mu_o I}{4\pi a} \hat{\mathbf{k}} \int \sin \theta d\theta \end{aligned}$$

which is really not too bad considering the integral we had at the start of this problem.

When we get to the corner of the left hand side  $\theta = \frac{3\pi}{4}$  and when we start on the right hand side  $\theta = \frac{\pi}{4}$  and along the bottom wire  $\theta$  will be somewhere in between  $\frac{\pi}{4}$  and  $\frac{3\pi}{4}$ . Then  $\frac{\pi}{4}$  and  $\frac{3\pi}{4}$  are our limits of integration. We can perform this integral

$$\begin{aligned} \vec{\mathbf{B}}_b &= -\frac{\mu_o I}{4\pi a} \hat{\mathbf{k}} \int_{\frac{\pi}{4}}^{\frac{3\pi}{4}} \sin \theta d\theta \\ &= -\frac{\mu_o I}{4\pi a} \hat{\mathbf{k}} [-\cos \theta]_{\frac{\pi}{4}}^{\frac{3\pi}{4}} \\ &= -\frac{\mu_o I}{4\pi a} \hat{\mathbf{k}} \left( \frac{\sqrt{2}}{2} - \left( -\frac{\sqrt{2}}{2} \right) \right) \\ &= -\frac{\mu_o I \sqrt{2}}{4\pi a} \hat{\mathbf{k}} \end{aligned}$$

This was just for the bottom of the loop. Now let's look at the top of the loop. There is finally some good news. The math will all be the same except for the directions. We had better work out  $d\vec{\mathbf{s}} \times \hat{\mathbf{r}}$  to see how different it is.

Now the  $d\vec{\mathbf{s}}$  is to the right and  $\hat{\mathbf{r}}$  is downward so

$$d\vec{\mathbf{s}} \times \hat{\mathbf{r}} = -dx \sin \theta \hat{\mathbf{k}}$$

But this is just as before. So even this is the same! The integral across the top wire

will have exactly the same result as the integral across the bottom wire. We can just multiply our previous result by two.

How about the sides? Again we get the same  $d\vec{s} \times \hat{r}$  direction and all the rest is the same, so our total field is

$$\vec{B} = 4\vec{B}_b = -\frac{\mu_o I \sqrt{2}}{\pi a} \hat{k}$$

This was a long hard, messy problem. But current loops are important! Every electric circuit is a current loop. Does this mean that every circuit is making a magnetic field?

Question 223.39.6

The answer is yes! As you might guess, this can have a profound effect on circuit design. If your circuit is very sensitive, adding extra fields (and therefore extra forces on the charges) can be disastrous causing the design to fail. There is some concern about “electronic noise” and possible effects on the body (cataracts are one side effect that is well known). And of course, as the circuit changes its current, the field it creates changes. this can create the opportunity for espionage. The field exists far away from the circuit. A savvy spy can determine what your circuit is doing by watching the field change!

## Long Straight wires

In our last example, we found that the magnitude of the field due to a wire is

$$B = \left| -\frac{\mu_o I}{4\pi a} \int \sin \theta d\theta \right|$$

Of course, we would like to relate this to our standard charge configuration, in this case an infinite line of (now moving) charge. If the wire is infinitely long, then the limits of integration are just from  $\theta = 0$  to  $\theta = \pi$

$$\begin{aligned} B &= \left| -\frac{\mu_o I}{4\pi a} \int_0^\pi \sin \theta d\theta \right| \\ &= \left| -\frac{\mu_o I}{4\pi a} (-\cos \theta) \Big|_0^\pi \right| \\ &= \frac{\mu_o I}{2\pi a} \end{aligned}$$

This is an important result. We can add a new geometry to our list of special cases, a long straight wire that is carrying a current  $I$ . The direction of the magnetic field, we already know, is given by our right-hand-rule. Of course, if our wire is not infinitely long, we now know how to find the actual field. It is all a matter of finding the right limits of integration.

Question 223.39.7



## Magnetic dipoles

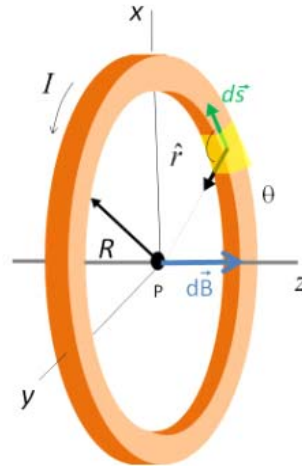

As a second example, let's find the magnetic field due to a round loop at the center of the loop. We start again with

$$\vec{\mathbf{B}} = \frac{\mu_o I}{4\pi} \int \frac{d\vec{\mathbf{s}} \times \hat{\mathbf{r}}}{r^2}$$

We need to find  $d\vec{\mathbf{s}} \times \hat{\mathbf{r}}$  and  $r$ , to do the integration. Our steps are:

1. Find an expression for  $d\vec{\mathbf{s}} \times \hat{\mathbf{r}}$ , this is a vector
2. Find an expression for  $r$
3. Turn three-dimensional problems into three one-dimensional problems by taking components
4. Assemble the integral, including limits of integration
5. Solve the integral.

Let's start with the first step. As we go around the loop  $d\vec{\mathbf{s}}$  and  $\hat{\mathbf{r}}$  will be perpendicular to each other, so

$$d\mathbf{s} \times \hat{\mathbf{r}} = ds \hat{\mathbf{k}}$$

For the second step, we realize that  $r$  is just the radius of the loop,  $R$ . Then the integration is quite easy (much easier to set up than the last case!)

$$\vec{\mathbf{B}} = \frac{\mu_o I}{4\pi} \int \frac{ds}{R^2} \hat{\mathbf{k}}$$

The limits of integration will be 0 to  $2\pi R$ . Notice that this is really a one-dimensional problem!  $B$  is a vector that points in the  $\hat{k}$  direction only. So we don't need to take components. Or in other words, we already know  $B_x$  and  $B_y$  are zero for this case. We can perform this integral

$$\begin{aligned} \vec{B} &= \frac{\mu_o I}{4\pi} \int_0^{2\pi R} \frac{ds}{R^2} \hat{k} \\ &= \frac{\mu_o I}{4\pi} \frac{2\pi R}{R^2} \hat{k} \end{aligned}$$

so

$$\vec{B} = \frac{\mu_o I}{2R} \hat{k} \quad \text{loop}$$

The field is perpendicular to the plane of the loop, which agrees with our square loop problem.

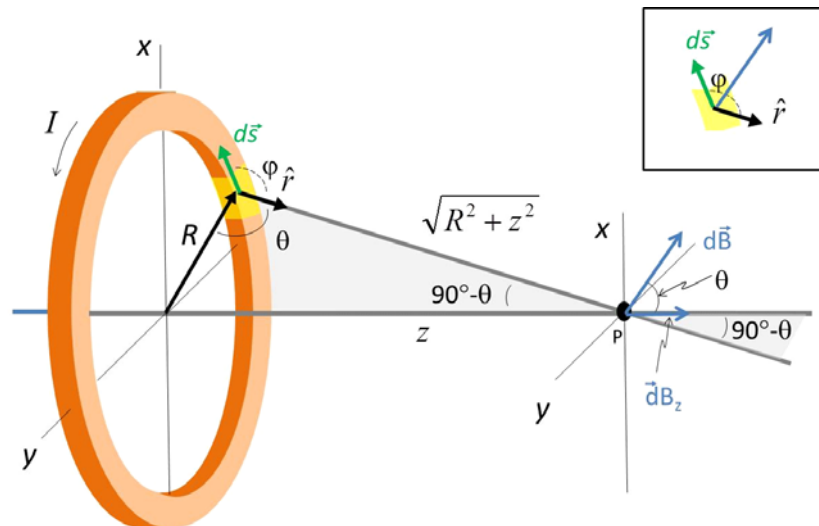

Let's extend this problem to a point along the axis a distance  $z$  away from the loop. Starting with step 1, we realize that, in general, our value of  $d\vec{s} \times \hat{r}$  is

$$d\vec{s} \times \hat{r} = ds \sin \phi$$

where  $\phi$  is the angle between  $d\vec{s}$  and  $\hat{r}$ . We can see that for this case  $\phi$  will still be  $90^\circ$ .

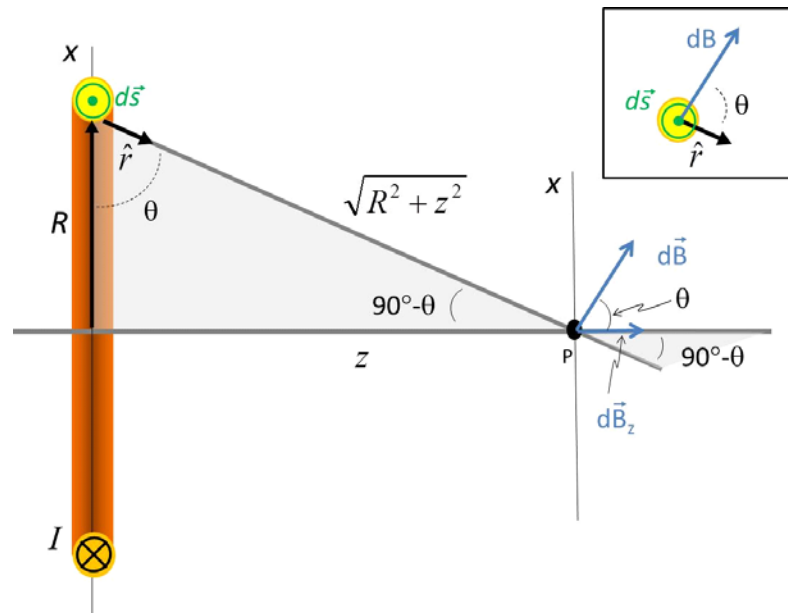

Side View

We have tipped  $\hat{r}$  toward our point  $P$ , but tipping  $\hat{r}$  from pointing to the center of the hoop to pointing to a point on the axis just rotated  $\hat{r}$  about part of the hoop. We still have  $\phi = 90^\circ$ . So

$$|d\vec{s} \times \hat{r}| = ds$$

with a direction shown in the figure. But our value of  $r$  is now more complicated

$$r = \sqrt{R^2 + z^2}$$

We have used symmetry to argue that we can take just  $x$  or  $y$ -components in the past because all the others clearly canceled out. We can also do that again here. Using symmetry we see that only the  $z$ -component of the magnetic field will survive. So we can take the projection onto the  $z$ -axis.

$$\vec{B} = \frac{\mu_o I}{4\pi} \int \frac{ds}{r^2} \cos \theta \hat{k}$$

We know how to deal with such a situation, since we have done this before. From the diagram we can see that

$$\cos \theta = \frac{R}{\sqrt{R^2 + z^2}}$$

so our field becomes

$$\vec{B} = \frac{\mu_o I}{4\pi} \hat{k} \int \frac{R ds}{(R^2 + z^2)^{\frac{3}{2}}}$$

This is also a one-dimensional problem with  $\vec{B}$  only in the  $\hat{k}$  direction. Fortunately this

integral is also not too hard to do. Let's take out all the terms that don't change with  $ds$

$$\vec{\mathbf{B}} = \frac{\mu_o IR}{4\pi (R^2 + z^2)^{\frac{3}{2}}} \hat{\mathbf{k}} \int_0^{2\pi R} ds$$

The limits of integration are 0 to  $2\pi R$ , the circumference of the circle

$$\begin{aligned} \vec{\mathbf{B}} &= \frac{\mu_o IR 2\pi R}{4\pi (R^2 + z^2)^{\frac{3}{2}}} \hat{\mathbf{k}} \\ &= \frac{\mu_o IR^2}{2 (R^2 + z^2)^{\frac{3}{2}}} \hat{\mathbf{k}} \end{aligned}$$

Let's take some limiting cases to see if this makes sense. Suppose  $z = 0$ , then

$$\begin{aligned} \vec{\mathbf{B}} &= \frac{\mu_o IR^2}{2 (R^2 + 0)^{\frac{3}{2}}} \hat{\mathbf{k}} \\ &= \frac{\mu_o IR^2}{2R^3} \hat{\mathbf{k}} \\ &= \frac{\mu_o I}{2R} \hat{\mathbf{k}} \end{aligned}$$

which is what we got before for the field at the center of the loop. That is comforting.

Now suppose that  $z \gg R$ . In that case, we can ignore the  $R^2$  in the denominator.

$$\begin{aligned} \vec{\mathbf{B}} &\approx \frac{\mu_o IR^2}{2 (z^2)^{\frac{3}{2}}} \hat{\mathbf{k}} \\ &= \frac{\mu_o IR^2}{2z^3} \hat{\mathbf{k}} \end{aligned}$$

We have just done this for on-axis positions because the math is easy there. But we could find the field at other locations. The result looks something like this.

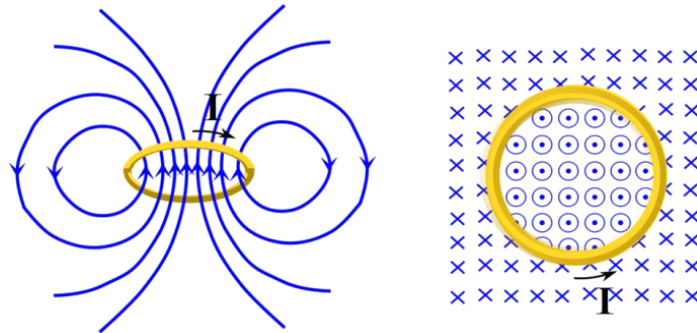

The figure on the left was taken from the pattern in iron filings that was created by an actual current loop field. The figure to the right is a top down look. We will use the symbol  $\odot$  to mean “coming out of the page at you” and the symbol  $\otimes$  “going into the page away from you.” Imagine these as parts of an arrow. The dot in the circle is the arrow tip coming at you, and the cross is the tail going away from you. Notice that the field is up through the loop, and down on the outside.

As we generalize our solution for the magnetic field far from the loop we have

$$\vec{B} \approx \frac{\mu_o I R^2}{2r^3} \hat{k}$$

This looks a lot like the electric field from a dipole

$$\vec{E} = \frac{2}{4\pi\epsilon_o} \frac{\vec{P}}{r^3}$$

which gives us an idea. We have a dipole moment for the electric dipole. This magnetic field has the same basic form as the electric dipole. We can rewrite our field as

$$\begin{aligned} \vec{B} &\approx \frac{\mu_o I (\pi R^2)}{2 (\pi) r^3} \hat{i} \\ &= \frac{\mu_o (2) I (A)}{(2) 2 (\pi) r^3} \hat{i} \\ &= \frac{\mu_o 2IA}{4\pi} \frac{\hat{i}}{r^3} \end{aligned}$$

where  $A = \pi R^2$  is the area of the loop.

The electric dipole moment is the charge multiplied by the charge separation

$$p = qa$$

we have something like that in our magnetic field, The terms  $IA$  describe the amount of charge and the geometry of the charges. We will call these terms together the *magnetic dipole moment*

$$\mu = IA$$

and give them a direction so that  $\mu$  is a vector. The direction will be from south to north pole

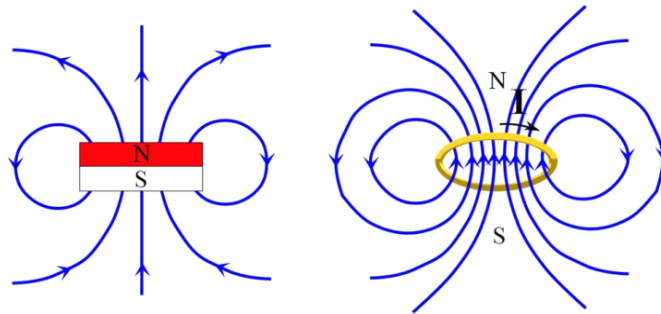

where we can find the south and north poles by comparison to the field of a bar magnet.

$$\vec{\mu} = IA \quad \text{from South to North}$$

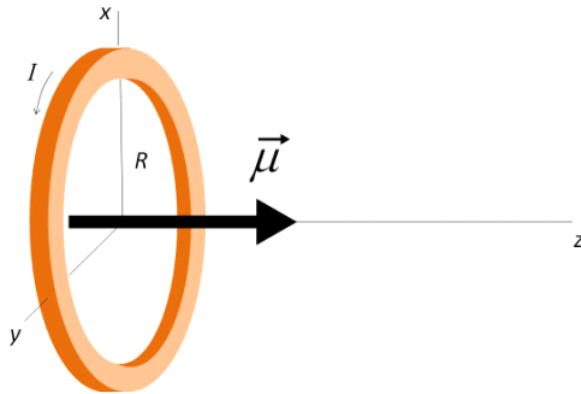

This is a way to characterize an entire current loop.

As we get farther from a loop, the exact shape of the loop becomes less important. So as long as  $r$  is much larger than  $R$ , we can write

$$\vec{\mathbf{B}} \approx \frac{\mu_0}{4\pi} \frac{2\vec{\mu}}{r^3} \hat{\mathbf{k}}$$

for any shaped current loop.

The integral form of the Biot-Savart law is very powerful. We can use computers to calculate the field due to any type of current configuration. But by hand there are only a few cases we can do because the integration becomes difficult. With electrostatics, we found ways to use geometry to eliminate or at least make the integration simpler. We will do the same thing for magnetostatics starting with the next lecture. Our goal will be to use geometry to avoid using Biot-Savart when we can.

## Basic Equations

# 24 Ampere's law, and Forces on Charges

## Fundamental Concepts

- The magnetic field can be found more simply for symmetric currents using Ampere's law  $\oint \vec{B} \cdot d\vec{s} = \mu_o I_{through}$
- The force due to the magnetic field on a charge,  $q$ , is given by  $\vec{F} = q\vec{v} \times \vec{B}$

## Ampere's Law

The Biot-Savart law is a powerful technique for finding a magnetic field, but it is more powerful numerically than in closed-form problems. We can only find exact solutions to a few problems with special symmetry. Since problems we can do by hand require special symmetry anyway, we would like to use symmetry as much as possible to remove the need for difficult integration.

We saw this situation before with electrostatics. We did some integration to find fields from charge distributions, but then we learned Gauss' law, and that was easier because it turned hard integration problems into relatively easy ones. This still required special symmetry, but when it worked, it was a fantastic time saver. For non-symmetric problems, there is always the integration method, and a computer.

Likewise, for magnetostatics there is an easier method. To see how it works, let's review some math.

In the figure there is a line, divided up into many little segments.

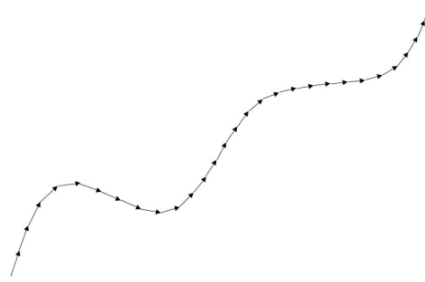

We can find the length of the line by adding up all the little segment lengths

$$L = \sum_i \Delta s_i$$

Integration would make this task less tedious

$$L = \int ds$$

This is called a line integral. Our new method of finding magnetic fields will involve line integrals. The calculation of the length is too simple, however. We will have to integrate some quantity along the line. For example, we could envision integrating the amount of energy lost when pushing a box along a path. The integral would give the total energy loss. The amount of energy lost would depend on the specific path. Thus a line integral

$$W = \int \vec{\mathbf{F}} \cdot d\vec{\mathbf{s}}$$

would be useful to find the total amount of work. Each small line segment would give a differential amount of work

$$dW = \vec{\mathbf{F}} \cdot d\vec{\mathbf{s}}$$

and we use the integral to add up the contribution to the work for each segment of size  $ds$  along the path. Notice the dot product. We need the dot product because only the component of the force in the direction the box is going adds to the total work done.

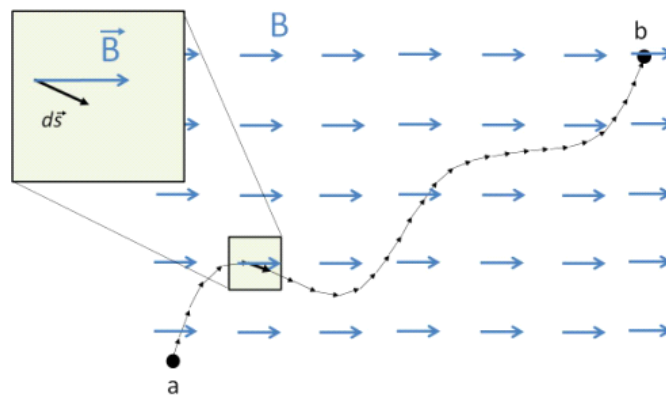



We wish to do a similar thing for our magnetic field. We wish to integrate the magnetic field along a path. The integral would look like this

$$\int_a^b \vec{B} \cdot d\vec{s}$$

This may not look like an improvement over integrating using the Biot-Savart law, but our goal will be to use symmetry to make this integral very easy. The key is in the dot product. We want only the component of the magnetic field that is in the  $d\vec{s}_i$  direction. There are two special cases.

If the field is perpendicular to the  $d\vec{s}_i$  direction, then

$$\int_a^b \vec{B} \cdot d\vec{s} = 0$$

because  $\vec{B} \cdot d\vec{s}_i = 0$  for this case

If the field is in the same direction as  $d\vec{s}_i$ , then  $\vec{B} \cdot d\vec{s}_i = Bds$  and

$$\int_a^b \vec{B} \cdot d\vec{s} = \int_a^b Bds$$

Further if we can make it so that  $B$  is constant and everywhere tangent to the path, then

$$\begin{aligned} \int_a^b \vec{B} \cdot d\vec{s} &= \int_a^b Bds \\ &= B \int_a^b ds \\ &= BL \end{aligned}$$

This process should look familiar. We used similar arguments to make the integral  $\int \vec{E} \cdot d\vec{A}$  easy for Gauss' law.

With Gaussian surfaces, we found we could imagine any surface we wanted. In a similar way, for our line integral we can pick any path we want. If we can make  $B$  constant and everywhere tangent to the path, then, the integral will be easy. It is important to realize that we get to make up our path. There may be some physical thing along the path, but there is no need for there to be. The paths we will use are imaginary.

Usually we will want our path to be around a closed loop. Let's take the case of a long straight current-carrying wire. We know the field shape for this. We can see that if we take a crazy path around the wire, that  $\vec{B} \cdot \Delta\vec{s}_i$  will give us the projection of  $\vec{B}$  onto the  $\Delta\vec{s}_i$  direction for each part of the path.

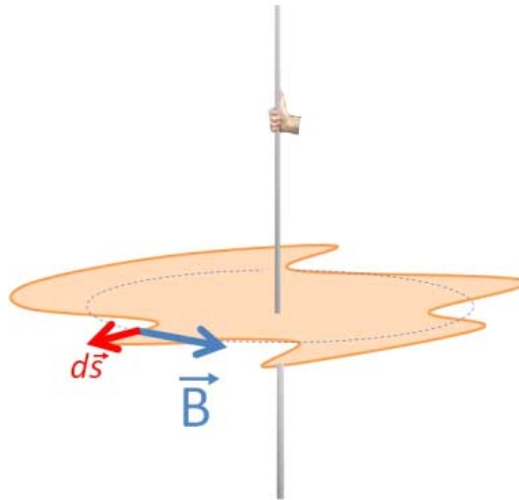

We get

$$\sum_i B_{\parallel} \Delta s$$

or in integral form

$$\int B_{\parallel} ds$$

The strange shape I drew is not very convenient. This is neither the case where  $\vec{B} \cdot d\vec{s}_i = 0$  nor where  $\vec{B} \cdot d\vec{s}_i = B ds$ . But if we think for a moment, I do know a shape where  $\vec{B} \cdot d\vec{s}_i = B ds$ . If we choose a circle, then from symmetry  $B$  will be constant, and it will be in the same direction as  $ds$  so  $\vec{B} \cdot d\vec{s}_i = B ds$ . From our last lecture we even know what the field should be.

$$B = \frac{\mu_o I}{2\pi r}$$

Let's see if we can use this to form a new general approach. Since  $B$  is constant around the loop, we can write our line integral as

$$\begin{aligned} \int \vec{B} \cdot d\vec{s} &= B 2\pi r \\ &= \frac{\mu_o I}{2\pi r} 2\pi r \\ &= \mu_o I \end{aligned}$$

This is an amazingly simple result. We integrated the magnetic field around an imaginary loop path, and got that the result is proportional to the current in the wire. This reminds us of Gauss' law where we integrated the electric field around a surface and got that the result is proportional to the amount of charge inside the surface.

$$\int \vec{E} \cdot d\vec{A} = \frac{Q_{in}}{\epsilon_o}$$

Let's review. Why did I pick a circle as my imaginary path? Because it made my math easy! I don't want to do hard math to compute the field, so I tried to find a path over which the math was as easy as possible. Since the path is imaginary, I can choose any path I want, so I chose a simple one. I want a path where  $\vec{B} \cdot d\vec{s}_i = 0$  or where  $\vec{B} \cdot d\vec{s}_i = B ds$ . This is very like picking Gaussian surfaces for Gauss' law. If I chose a harder path I would get the same answer, but it would take more effort. I found the result of my integral  $\int \vec{B} \cdot d\vec{s}$  to be just  $\mu_o I$ .

We had to integrate around a closed path, so I will change the integral sign to indicate that we integrated over a closed path.

$$\oint \vec{B} \cdot d\vec{s} = \mu_o I_{through} \quad (24.1)$$

and only the current that went through the imaginary surface contributed to the field, so we can mark the current as being the current that goes through our imaginary closed path.

This process was first discovered by Ampere, so it is known as Ampere's law.

Let's use Ampere's law to do another problem. Suppose I have a coil of wire. This coil is effectively a stack of current rings. We know the field from a single ring.

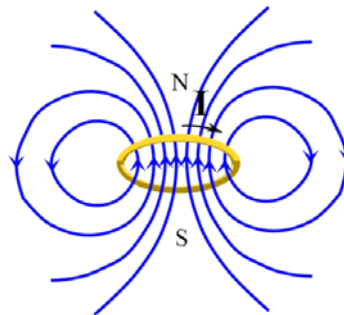

$$B = \frac{\mu_o I}{2R}$$

But what would the field be that is generated by having a current flow through the coil?

Well, looking at the single loop picture, we see that the direction of the field due to a loop is right through the middle of the loop. I think it is reasonable to believe that if I place another loop on top of the one pictured, that the fields would add, making a stronger field down the middle. This is just what happens. So I could write our loop

field equation as

$$B = N \frac{\mu_o I}{2r}$$

where  $N$  is the number of loops I make. It is customary in electronics to define  $n$  as the number of loops per unit length (sort of like the linear mass density we defined in waves on strings, only now it is linear loop density). Suppose I take a lot of loops! In the picture I have drawn the loops like a cross section of a spring. But now the loops are not all at the same location. So we would guess that our field will be different than just  $N$  times the field due to one loop. We can use Ampere's law to find this field?

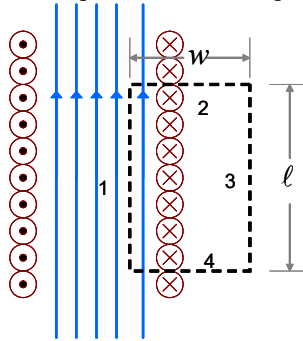

Consider current is coming out at us on the LHS and is going back into the wires on the RHS. Remember our goal is to use Ampere's law

$$\oint \vec{B} \cdot d\vec{s} = \mu_o I_{through}$$

to find the field. Let's imagine a rectangular shaped *Amperian* loop shown as a dotted black line. Note that like Gaussian surfaces, this is an imaginary loop. Nothing is really there along the loop. Let's look at the integral by breaking it into four pieces,

$$\int_1 \vec{B} \cdot d\vec{s} + \int_2 \vec{B} \cdot d\vec{s} + \int_3 \vec{B} \cdot d\vec{s} + \int_4 \vec{B} \cdot d\vec{s} = \mu_o I_{through}$$

one for each side of the loop. If I have chosen my loop carefully, then  $\vec{B} \cdot d\vec{s}_i$  will either be  $\vec{B} \cdot d\vec{s}_i = 0$  or  $\vec{B} \cdot d\vec{s}_i = B ds$ . Let's start with side 2. We want to consider

$$\vec{B} \cdot d\vec{s}_2$$

We see that for our side 2 the field is perpendicular to  $d\vec{s}_2$  So

$$\mathbf{B} \cdot d\vec{\ell}_2 = 0$$

This is great! I can integrate 0

$$\int 0 = 0$$

The same reasoning applies to

$$\vec{B} \cdot d\vec{s}_4 = 0$$

From our picture we can see that there is very little field outside of our coil of loops. So  $B_3$  is very small, so  $\vec{B} \cdot d\vec{s}_3 \approx 0$ . It is not exactly zero, but it is small enough that I will

call it negligible for this problem. For an infinite coil, this would be exactly true (but infinite coils are hard to build).

That leaves path 1. There the  $B$ -field is in the same direction as  $d\vec{s}_1$  so

$$\vec{B} \cdot d\vec{s}_1 = B ds_1$$

Again this is great!  $B$  is fairly uniform along the coil. Let's say it is close enough to be considered constant. Then the integral is easy over side 1

$$\int B ds_1 = B\ell$$

We have performed the integral!

$$\begin{aligned} \oint \vec{B} \cdot d\vec{s} &= \int_1 \vec{B} \cdot d\vec{s} + \int_2 \vec{B} \cdot d\vec{s} + \int_3 \vec{B} \cdot d\vec{s} + \int_4 \vec{B} \cdot d\vec{s} \\ &= B\ell + 0 + 0 + 0 \\ &= B\ell \end{aligned}$$

Now we need to find the current in the loop. This is more tricky than it might appear. It is not just  $I$  because we have several loops that go through our loop, each on it's own carrying current  $I$  and each contributing to the field. We can use a linear loop density<sup>16</sup>  $n$  to find the number of loops.

$$N = n\ell$$

and the current inside the loop will be

$$I_{inside} = NI$$

Then, putting the integration all together, we have

$$\oint \vec{B} \cdot d\vec{s} = B\ell + 0 + 0 + 0 = \mu_o NI$$

or

$$B\ell = \mu_o NI$$

which gives a field of

$$B = \mu_o \frac{N}{\ell} I$$

or

$$B = \mu_o n I$$

This device is so useful it has a name. It is a solenoid. You may have made a coil as a kid and turned it into an electromagnet by hooking it to a battery (a source of potential difference) so that a current ran through it. In engineering solenoids are used as current controlled magnetic switches.

---

<sup>16</sup> Physicists like densities!

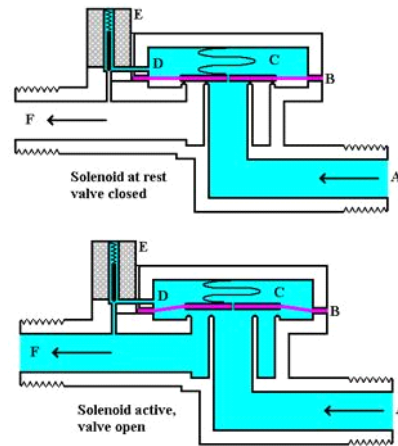

Solenoid operated valve system.

There is another great thing about a solenoid. In the middle of the solenoid, the field is really nearly constant. Near the ends, there are edge effects, but in the middle we have a very uniform field. This is analogous to the nearly uniform electric field inside a capacitor. We can therefore see how to generate uniform magnetic fields and consider uniform  $B$ -fields in problems. Such a large nearly uniform magnetic field is part of the Compact Muon Solenoid (CMS) experiment at CERN.



CMS Detector at CERN. The detector is constructed of a very large solenoid to bend the path of the charge particles.

## Magnetic Force on a moving charge

Now that we know how to generate a magnetic field, we can return to thinking about magnetic forces on moving charges. Our magnetic field is slightly more complicated than the electric field. We can still use a charge and the force, but now the charge is moving so we expect to have to include the velocity of the charge. We want an expression that relates  $B$  and  $F_{mag}$  in both magnitude and direction.

Our expression for the relationship between charge, velocity, field and the force comes from experiment (although now we can derive it). The experiments show that when a charged particle moves parallel to the magnetic field, there is no force! This is radically different from our  $E$ -field! Worse yet, the force seems to be perpendicular to both  $v$  and  $B$  when the angle between them is not zero! Here is our expression.

$$\mathbf{F}_B = q\mathbf{v} \times \mathbf{B} \quad (24.2)$$

where  $q$  is the moving charge and  $B$  is the magnetic field environment.

We have a device that can shoot out electrons. The electrons show up because they hit a phosphorescent screen. When we bring a magnet close to our beam of electrons, we find it moves!

But we did this with moving electrons, what happens if they are not moving? We might expect the electrons to accelerate just the same—and we would be wrong! Static charges seem to not notice the presence of the magnet at all!

We expect that, like gravity and electric charge, the force on the moving electrons must be due to a field, but this *magnetic field* does not accelerate stationary electrons. We learned before that the reason we know that there is some force on the electrons came when Oersted, a Dutch scientist experimenting with electric current, found that his compass acted strangely when it was near a wire carrying electric current. This discovery is backwards of our experiment. It implies that moving charges must effect magnets, but given Newton's third law, If moving electrons make a field that makes a force on a magnet, then we would expect a magnet will make a field that makes a force on moving charges as well!

The derivation of the magnitude of the force from the experimental data is tedious. We will just learn the results, but they are exciting enough! The magnitude of the force on a moving charge due to a constant magnetic field is

$$\vec{F}_B = q\vec{v} \times \vec{B} \quad (24.3)$$

The magnitude is given by

$$F = qvB \sin \theta$$

where  $q$  is charge,  $v$  is speed, and  $B$  is the magnitude of the magnetic field We need to carefully define  $\theta$ . Since we have a cross product,  $\theta$  is the angle between the field direction and the velocity direction.

We can solve the equation for the magnetic field force (equation 24.3) to find the magnitude of the field

$$\frac{F}{qv \sin \theta} = B$$

But the strangeness has not ended. we need a direction of the force. And it turns out that it is perpendicular to both  $\vec{v}$  and  $\vec{B}$  as the cross product implies! We use our favorite right hand rule to help us remember.

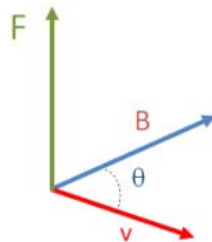



We start with our hand pointing in the direction of  $\vec{v}$ . Curl your fingers in the direction of  $\vec{B}$ . And your fingers will point in the direction of the force. We saw this type of right hand rule before with torque, but there is one big difference. This really is the direction the charge will accelerate! Note that this works for a positive charge. If the charge is negative, then the  $q$  in

$$\vec{F}_B = q\vec{v} \times \vec{B}$$

will be negative, and so the force will go in the other way. To keep this straight in my own mind, I still use our right hand rule, and just remember that if  $F$  is negative, it goes the opposite way of my thumb.

Right hand rule #2: We start with our hand pointing in the direction of  $\vec{v}$ . Curl your fingers in the direction of  $\vec{B}$ . And your fingers will point in the direction of the force. The magnitude of the force is given by

$$F = qvB \sin \theta \tag{24.4}$$

### Motion of a charged particle in a $B$ -Field

Question 223.40.1

Question 223.40.2

Question 223.40.3

Question 223.40.5

We refer to the magnetic field as a  $B$ -field for short.

Let's set up a constant  $B$ -field as shown in the figure. We draw a  $B$ -field as a set of vectors just like we did for electric fields. In the figure, the vectors are all pointing "into the paper" so all we can see is their tails.

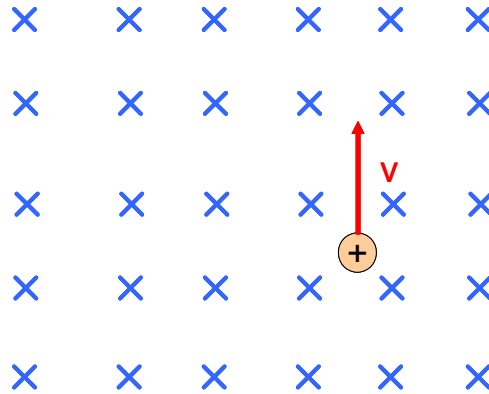

Question 223.40.6

If I have a charged particle, with velocity  $\vec{v}$ , what will be the motion of the particle in the field? First off, we should recall that  $\vec{F}$  is in a direction perpendicular to  $\vec{v}$  and  $\vec{B}$ . Using our right hand rule we see that it will go to the left.

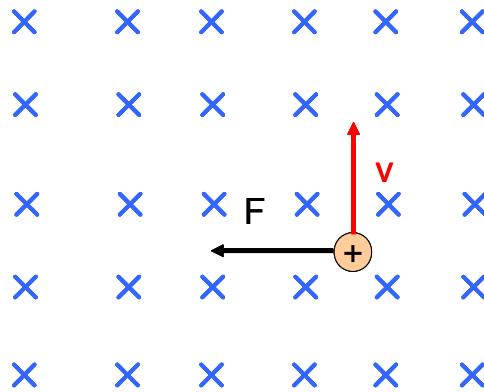

Remember that  $F = ma$ , so the charge will accelerate in the  $-x$  direction.

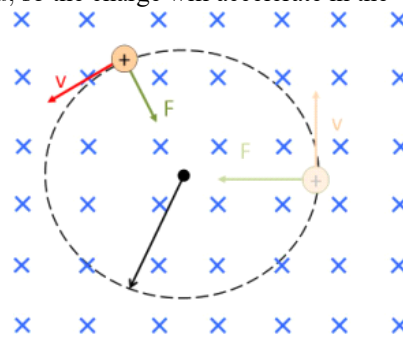

Now, if we allow the charged particle to move, we see that the  $v$  direction changes. This makes the direction of  $F$  change. Since  $v$  and  $a$  are always at  $90^\circ$ , the motion reminds us of circular motion! Let's see if we can find the radius of the circular path of the charge.

$$F = qvB \sin \theta$$

will be just

$$F = qvB$$

because  $\theta$  is always  $90^\circ$ . Then, using Newton's second law

$$F = ma = qvB$$

and noting that the acceleration is center-seeking, we can write it as a centripetal acceleration

$$a = \frac{v^2}{r}$$

Then

$$m \frac{v^2}{r} = qvB$$

$$m \frac{v}{r} = qB$$

We can find the radius of the circle

$$\frac{mv}{qB} = r$$

Could we find the angular speed?

$$\omega = \frac{v}{r} = \frac{qB}{m}$$

How about the period? We can take the total distance divided by the total time for a revolution

$$v = \frac{2\pi r}{T}$$

to find

$$T = \frac{2\pi r}{v}$$

and we recognize

$$\frac{1}{\omega} = \frac{r}{v}$$

so

$$T = \frac{2\pi}{\omega}$$

so, using our angular speed we can say

$$T = \frac{2\pi m}{qB}$$

The angular frequency  $\omega$  that we found is the frequency of a type of particle accelerator called a cyclotron. This type of accelerator is used by places like CERN to start the acceleration of charged particles. The same concept is used to make the charged particles go in a circular path in the large accelerators like the LHC at CERN.



Turning magnets at CERN. This is an actual magnet, but this magnet is at ground level in the testing facility. The tunnel is a mock-up of what the actual beam tunnel looks like.

Within the detector systems, like the CMS, charged product particles can be tracked along curved paths for identification.

Question 223.40.7

Question 223.40.8

Question 223.40.9

But it is also interesting to know that charged particles that enter a magnetic field with

some initial speed will gain a circular motion as well.

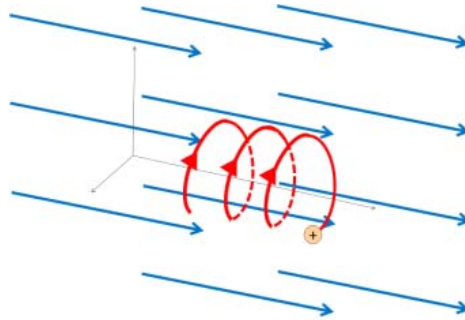

An example is the charged particles from the Sun entering the Earth's magnetic field. the particles will spiral around the magnetic field lines.

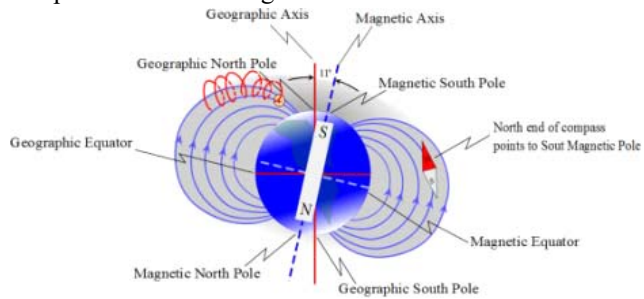

As the helical motion tightens near the poles, the particles will sometimes give off patterns of light as they hit atmospheric atoms.



Aurora Borealis: Sand Creek Ponds Idaho 2013

The light is what we call the aurora borealis. A more high-tech use for this helical motion is the confinement of charged particles in a magnetic field for fusion reaction.

## The velocity selector

Question 223.40.10

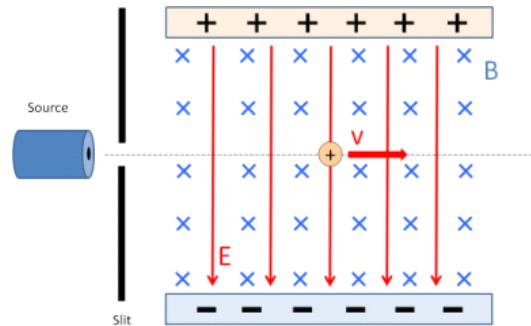

This device shows up on tests, especially finals, because it has both an electric field and a magnetic field—you test two sets of knowledge at once! So let's see how it works. Our question should be, what is the velocity of a charged particle that travels through the field without being deflected?

### $E$ -field

We remember that the force on a positively charged particle will be

$$F_E = qE$$

directed in the field direction so it is downward.

### $B$ -Field

Now we know that

$$\mathbf{F}_B = q\mathbf{v} \times \mathbf{B}$$

and we use our right hand rule to find that the direction will be upward with a magnitude of

$$\begin{aligned} F_B &= qvB \sin \theta \\ &= qvB \end{aligned}$$

So there will be no deflection (no acceleration) when the forces in the  $y$ -direction balance.

$$\Sigma F_y = 0 = -F_E + F_B$$

or

$$qE = qvB$$

which gives

$$v = \frac{E}{B}$$

as the speed that will be “selected.”

## Bainbridge Mass Spectrometer

You may use a mass-spec some time in your careers. I have had samples identified by mass-spectrometers several times in my industrial career. They are very useful devices—especially when chemical identification is hard or impossible.

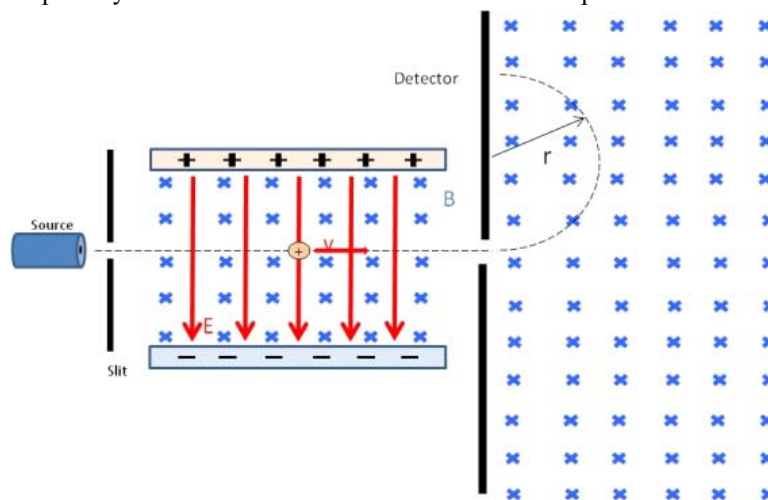

The Bainbridge device is one type that we can easily understand. It starts with a velocity selector which sends charged particles at a particular speed into a region of uniform magnetic field. The charged particles then follow curved paths on their way to an array of detectors. When they hit the array, their spatial location is recorded. Where they hit depends on their ratio of charge to mass. From our study of the rotational motion we found

$$r = \frac{mv}{qB_o}$$

so the charge to mass ratio is

$$\frac{q}{m} = \frac{v}{rB_o}$$

Since we know the initial velocity will be

$$v = \frac{E}{B}$$

from the velocity selector, then

$$\frac{q}{m} = \frac{E}{rBB_o}$$

One way this is often used is to separate a sample of substance, say, carbon to find the

relative amount of each isotope. The carbon atoms will all ionize to the same charge. Then the position at which they are detected depends on the mass.

I used a mass-spec in my last industry project to identify large carbon compounds and their relative concentration in complex oil leaks. This data helped us look for possible leak detection targets so pipeline leaks could be detected before the oil was visible to the naked eye.

## Classical Cyclotron

We already found the period of rotation of a charged particle in a uniform magnetic field.

$$T = \frac{2\pi m}{qB}$$

Note that this does not depend on the speed of the particle! So it will have the same travel time regardless of how fast it goes. We can use this to accelerate particles. But we add in an electric field to do the acceleration. The device is shown in the figure below

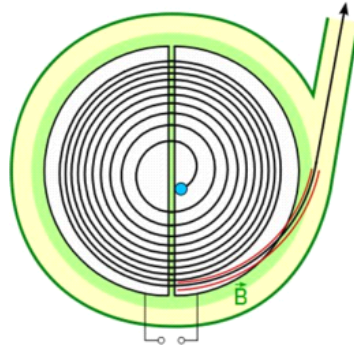

Basic Geometry of the Cyclotron. (Public Domain image courtesy KlausFoehl)

The particle starts in the center circling around in the magnetic field. but the device is divided into halves (called “Ds”). There is a gap between the Ds, and the electric field is created in the gap. One side at high potential and the other at low potential. When the particle is in the gap, it accelerates. It will gain a kinetic energy equal to the potential energy difference across the gap

$$\Delta K = q\Delta V$$

As the particle travels around the D to the other side of the, the cyclotron switches the polarity of the potential difference. So as it passes the gap on the other side of the cyclotron, it is again accelerated with an additional  $\Delta K = q\Delta V$ . Since  $r$  does depend on the speed,

$$r = \frac{mv}{qB}$$

the radius increases with each “kick.” Finally the particle leaves the cyclotron with a velocity of

$$\frac{qBr_{\max}}{m} = v$$

Since we often describe the velocity of particles in energy terms, the kinetic energy of the particle

$$\begin{aligned} K &= \frac{1}{2}mv^2 \\ &= \frac{1}{2}m \left( \frac{qBr_{\max}}{m} \right)^2 \\ &= \frac{q^2 B^2 r_{\max}^2}{2m} \end{aligned}$$

## Hall Effect

### Hall Effect Demo

The Hall probe is a cool little device that measures the magnitude of the magnetic field. We should find out how it works.

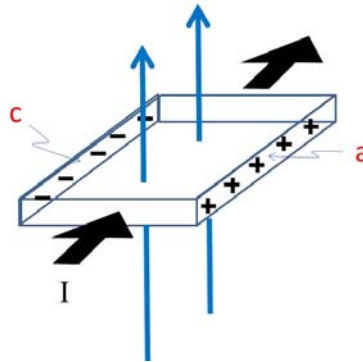

Let's take a piece of material that has a current going through it. If we place it in a magnetic field, then the charge carriers will feel a force. Suppose it is a metal, and that the charge carriers are electrons. The force is perpendicular to the current direction. So the electrons are accelerated toward the top of the piece of metal as shown in the drawing. This creates a negative charge on the top side of the metal piece. Then the bottom side will be positively charged relative to the top. With separated charge like this, we think of a capacitor and the electric field created by such a separation of charges. There will be a field in the conductor with a potential difference between the top and bottom of the conductor. We call this potential difference

$$\Delta V_H$$



the Hall potential after the man who first observed it.

Now if the charge carriers were positive, we would still build up a potential, but it would be in the opposite polarity. We wish to find this hall potential. The electric field of the charges will try to push them back down as more charge builds up. So at some point the upward force due to the magnetic field on the electrons will be balanced by the built up electric field. At that point

$$\Sigma F_y = 0 = F_B - F_E$$

so

$$qv_d B = qE_H$$

where  $E_H$  is the field due to the separation of charges.

So

$$E_H = v_d B$$

The potential is nearly equal to

$$\Delta V \approx E_H d$$

where  $d$  is the top-to-bottom distance of the conductor, so

$$\Delta V \approx v_d B d$$

Since we know

$$I = nqAv_d$$

then

$$v_d = \frac{I}{nqA}$$

and the area  $A$  is

$$A = td$$

where  $t$  is the thickness of the conductor, then

$$v_d = \frac{I}{nqtd}$$

and

$$\Delta V \approx \frac{IB}{nqt}$$

You may find this expressed in terms of the Hall coefficient

$$R_H = \frac{1}{nq}$$

so

$$\Delta V \approx R_H \frac{IB}{t}$$

To do a good job of finding  $R_H$  for metals and semiconductors, you have to go beyond classical theory. But if we know  $B$ ,  $I$ ,  $t$ , and  $\Delta V$ , which can all be measured, then we can find  $R_H$ . Once this is done, we can place the Hall probe in different magnetic fields

to find their strength. One way to do this is to control  $I$  and measure  $\Delta V$ , so

$$B \approx \frac{t}{R_H I} \Delta V$$

## Basic Equations

# 25 Magnetic forces on wires

## Fundamental Concepts

- The magnetic force on moving charges extends to wires with currents
- The force on a wire with current is given by  $\mathbf{F}_I = I\mathbf{L} \times \mathbf{B}$
- The torque on a current loop is  $\boldsymbol{\tau} = \boldsymbol{\mu} \times \mathbf{B}$  where  $\boldsymbol{\mu} = I\mathbf{A}$

## Magnetic forces on Current-Carrying wires

Question 223.41.1

Question 223.41.2

If there is a force on a single moving charge due to a magnetic field, then there must be a force on lots of moving charges! We call lots of moving charges an electric current

$$I = \frac{\Delta Q}{\Delta t}$$

For charges in a wire, we know that the charges move along the wire with a velocity  $v_d$ . We would expect the total force on all the charges to be the sum of all the forces on the individual charges.

$$F_I = \sum_i F_{q_i} = \sum_i q_i v_d B \sin \theta$$

but, since in our wire all the charge carriers are the same, this is just

$$F_I = N q_i v_d B \sin \theta$$

where here  $N$  is the number of charge carriers in the part of the wire that is experiencing the field. We used a charge density  $n$  before. Let's use it again to make an expression for  $N$

$$N = nV = nAL$$

where  $A$  is the cross sectional area of the wire and  $L$  is the length of the wire. So

$$F_I = nALq_i v_d B \sin \theta$$

Now let's think back to our definition of current. We know that

$$I = nq_i v_d A$$

so our force on the current carrying wire is

$$\begin{aligned} F_I &= (nq_i v_d A) LB \sin \theta \\ &= ILB \sin \theta \end{aligned}$$

Remember that  $\theta$  is the angle between the field direction and the velocity. In this case  $I$  is in the direction of the velocity (we still assume positive charge carriers, even though we know they are electrons). So  $\theta$  is the angle between the field direction and the direction of the current. We can write this as a cross product

$$\vec{F}_I = I \vec{L} \times \vec{B} \quad (25.1)$$

where  $\vec{L}$  is in the current direction.

### Force between two wires

Question  
223.41.2.3  
MIT movies

We can use what we have learned to find the force between two wires.

If I have two wires with current, I will have a field created by each wire. Let's suppose that  $I_1$  and  $I_2$  are in the same direction

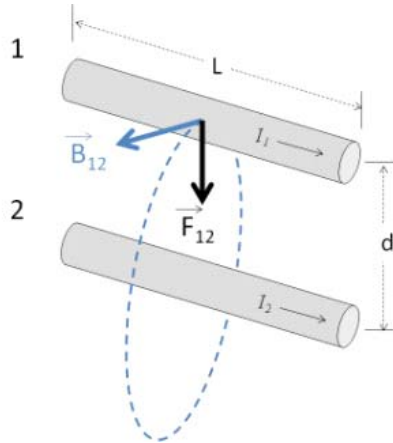

and let's calculate the force on wire 1 due to the field of wire 2. The field due to wire 2 at the location of wire 1 will be

$$B_{12} = \frac{\mu_0 I_2}{2\pi d}$$

where  $d$  is how far away wire 1 is from wire 2. We know

$$F_{12} = I_1 L B_2 \sin \theta$$

We can see that  $\sin \theta = 1$  since  $I_1$  will be perpendicular to  $B_{12}$ .

$$F_{12} = I_1 L B_{12}$$

and using our expression for  $B_{12}$

$$\begin{aligned} F_{12} &= I_1 L \frac{\mu_o I_2}{2\pi d} \\ &= L \frac{\mu_o I_2 I_1}{2\pi d} \end{aligned} \quad (25.2)$$

Would you expect  $F_{21}$  to be very different?

## Torque on a Current Loop

Question 223.41.4

Question 223.41.5

Remember that in PH121 or Statics and Dynamics we defined angular displacement

$$\Delta\theta = \theta_f - \theta_i \quad (25.3)$$

and this told us how far in angle we had traveled from a starting point  $\theta_i$ .

We also defined the angular velocity

$$\omega = \frac{\Delta\theta}{\Delta t} \quad (25.4)$$

which told us how fast an object was spinning in radians per second. The direction of this angular velocity we found using a right hand rule.

We also defined an angular acceleration

$$\alpha = \frac{\Delta\omega}{\Delta t} \quad (25.5)$$

and we used angular acceleration in combination with a moment of inertia to express a rotational form of Newton's second law

$$\sum \tau = I\alpha \quad (25.6)$$

where  $\tau$  is a torque. We found torque with the expression

$$\vec{\tau} = \vec{r} \times \vec{F} \quad (25.7)$$

We wish to apply these ideas to our new force on wires due to magnetism.

Let's take a specific example. I want to use a current loop. This is just the simple loop of current we have seen before.

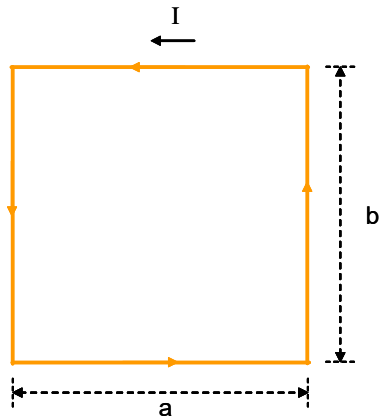

I want to place this into a magnetic field.

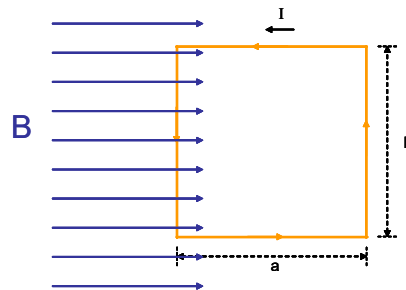

I drew the current loop as a rectangle on purpose, I want to look at the force on the current for each part of the loop. Each side of our loop is a straight wire segment. Remember that the magnitude of the force on a wire is given by

$$F_I = ILB \sin \theta$$

where  $\theta$  is the angle between  $I$  and  $B$  so if  $\theta = 0$  or if  $\theta = \pi$  rad, then  $\sin \theta$  will be zero. The magnitude of the force will then be zero. So the top and bottom parts of the loop will not experience a force. The sides will, though, and since for  $\theta = \frac{\pi}{2}$  or  $\theta = -\frac{\pi}{2}$  ( $\theta = -\frac{\pi}{2}$  is the same as  $\theta = \frac{3\pi}{2}$ ) then  $\sin \theta = 1$  and the force will be a maximum.

$$F_I = IbB$$

on each side wire segment. But we need to consider direction. The force will be perpendicular to both  $I$  and  $B$ . We use our right hand rule. Fingers in the direction of  $I$ , curl to the direction of  $B$ . We see the force is out of the figure for the left hand side and into the figure for the right hand side. The next figure is a bottom-up view.

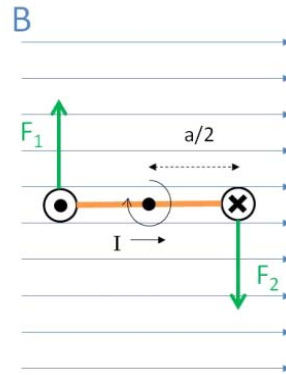

Clearly the loop will want to turn! This looks like a nice problem for us to describe with a torque. We have a force acting at a distance from a pivot. We have a torque

$$\tau = rF \sin \psi$$

We have already used  $\theta$ , and our torque angle is the angle between  $r$  and  $F$ , so we needed a new greek letter. I have used  $\psi$ <sup>17</sup>. Then  $\psi$  is the angle between  $r$  and  $F$ .

Let's fill in the details of our total torque. Remember we have two torques, one for the left hand side, and one for the right and side. Their magnitudes are the same, and the directions we need to get from yet another right hand rule. Both are in the same direction so

$$\begin{aligned} \tau &= \frac{a}{2} F_I \sin(\psi) + \frac{a}{2} (F_I) \sin(\psi) \\ &= a F_I \sin(\psi) \end{aligned}$$

Putting in the force magnitude gives

$$\tau = a (IbB) \sin \psi$$

and rearranging lets us see

$$\begin{aligned} \tau &= (ab) IB \sin \psi \\ &= (A) IB \sin \psi \end{aligned}$$

where  $A = ab$  is the area of our loop. Of course we can write this as

$$\vec{\tau} = I \vec{A} \times \vec{B} \quad (25.8)$$

The torque is the cross product of the area vector and the magnetic field multiplied by the current.

We did this for a square loop. It turns out that it works for any loop shape.

When things rotate, we expect to use moments. We defined a magnetic dipole moment

---

<sup>17</sup> which is a *psi*

for a current loop. Now we can see why it is useful. The magnetic moment tells us about how much torque we will get for a particular current loop.

$$\vec{\mu}_d = I\vec{A}$$

using this we have

$$\vec{\tau} = \vec{\mu}_d \times \vec{B}$$

We could envision our loop as a single circle of wire connected to a battery. But we could just as easily double up the wire. If we do this, what is our torque? Well we would have twice the force, because we now have twice the current (the current goes through both turns of the wire). So now we have

$$\tau = 2(A)IB \sin \psi$$

But why stop there? We could make three loops all together.

$$\tau = 3(A)IB \sin \psi$$

or many more, say  $N$  loops,

$$\tau = NAIB \sin \psi$$

Thinking of our magnetic dipole moment, we see that

$$\tau = N\mu_d B \sin \psi$$

for a coil. We could combine the effects of all the loops into one magnetic moment that represents the coil.

$$\vec{\mu} = N\vec{A}I \quad (25.9)$$

then

$$\tau = \mu B \sin \psi$$

or in cross product form

$$\vec{\tau} = \vec{\mu} \times \vec{B} \quad (25.10)$$

Using this total magnetic moment, we can more easily do problems with coils in magnetic fields.

For example, we found that there was a potential energy associated with spinning dipoles, for a spinning current loop we also expect a potential energy. We have a simple formula for this potential energy in terms of the magnetic moment.

$$U = -\vec{\mu} \cdot \vec{B} \quad (25.11)$$



## Galvanometer

We finally know enough to understand how to measure a current. The device is called a *galvanometer*.

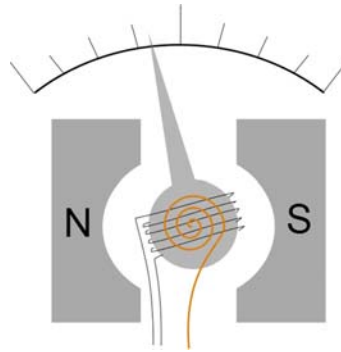

In the picture, we see the typical design of a galvanometer. It has a coil of wire (shown looking at the side of the coil) and a spring. The coil is placed between the ends of a magnet. When there is a current in the wire, there will be a torque on the coil that will compress the spring. The amount of torque depends on the current. As the current increases, the spring is more compressed. A marker (large needle) is attached to the apparatus. As the spring is compressed, the indicator moves across the scale. Since this movement is proportional to the current, a galvanometer can easily measure current.

## Electric Motors

Question 223.41.6

With our new understanding of torque on a current loop, we should be able to see how an electric motor works. A current loop is placed in between two magnets to form a magnetic field. The loop will turn because of the torque due to the  $B$ -field. But we have to get clever. What happens when the loop turns half way around so the current is now going the opposite way?

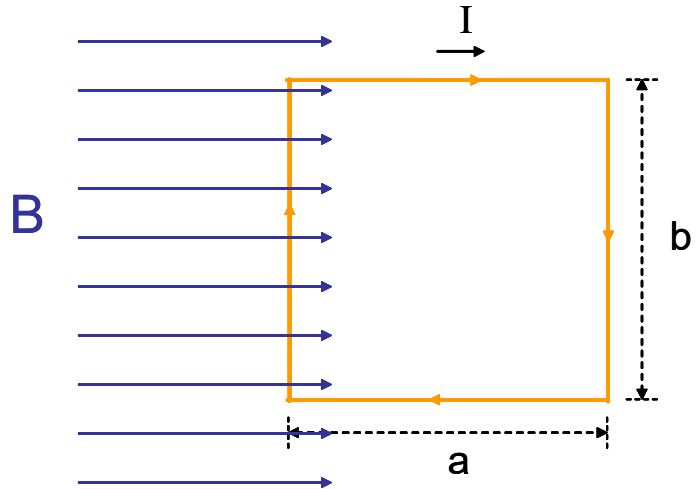

Now the torque switches direction and the loop will come to rest. We don't want that if we are building a motor, so we have to switch the current direction every time the loop turns half way.

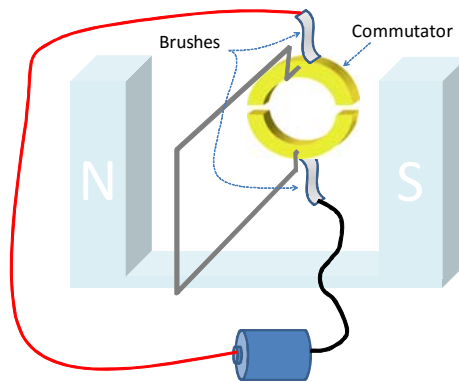

The way we do this is to have electrical contacts that are flexible, called brushes. The brushes contact a metal ring. The metal ring is connected to the loop. But the ring has two slits cut out of it.



The ring with slits is called a commutator. As the loop turns, the commutator turns, and when it has turned a half turn, the brushes switch sides. This changes the current direction, which puts us back at maximum torque.

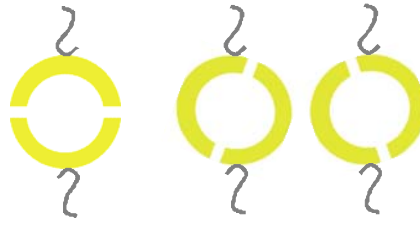

This keeps the motor going the same direction.

## Basic Equations



# 26 Permanent Magnets, Induction

## Fundamental Concepts

- Using classical physics, we can't quite explain a permanent magnet.
- Using a semiclassical model, the permanent magnet's field is due to spinning electrons.
- Alignment of the spinning electrons creates what we call magnetism.
- Temporary alignment results in paramagnetism and diamagnetism.
- More permanent alignment yields ferromagnetism.
- A changing magnetic field can create an emf.

## Finally, why magnets work

Question 223.42.1

We all would like to know how magnets work. Can a permanent magnet have something to do with current loops?

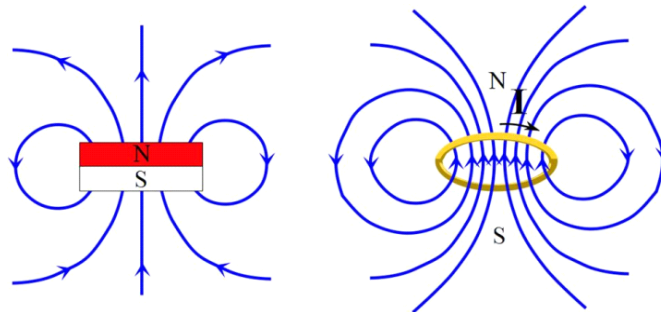

Well, let's look at the field due to a current loop. It looks a lot like the field due to a magnet. Could there be current loops inside a bar magnet? The answer is well, sort of... We have electrons that sort of travel around the atom. Suppose the electrons orbit like planets. Then there would be a current as they travel. For one electron the current

would be

$$I = \frac{q_e}{T}$$

where  $T$  is the period of rotation. It is an amount of charge per unit time. We can write this as

$$I = q_e \frac{\omega}{2\pi}$$

and recalling

$$v_t = \omega r$$

then

$$I = q_e \frac{v_t}{2\pi r}$$

We can find a magnetic moment (a good review of what we have learned!)

$$\begin{aligned} \mu &= NIA = (1) IA \\ &= q_e \frac{v_t}{2\pi r} (\pi r^2) \\ &= \frac{q_e v_t r}{2} \end{aligned}$$

Physicists often write this in terms of angular momentum. Just to review, angular momentum is given by

$$L = I_m \omega$$

where  $I_m$  is the moment of inertia. Then

$$\begin{aligned} L &= I_m \omega \\ &= (mr^2) \left( \frac{v_t}{r} \right) \\ &= mrv_t \end{aligned}$$

so the magnetic moment of the orbiting electron would be

$$\mu = \frac{q_e L}{2m} \quad (26.1)$$

which gives us a magnetic moment related to the angular momentum of the electron.

## Quantum effects

Question 223.42.2

All of this works well for Hydrogen. We find that individual hydrogen atoms do act like small magnets. But if the hydrogen is in a compound, it is more complicated because we then have many electrons and they are “orbiting” in different directions. It is even true that most atoms have many electrons, and within the atom these electrons y around in all different directions. The magnetic field due to one electron in the atom cancels out the magnetic field due to another, so there is no net magnetic field. So in general there is no net magnetic field. Even for Hydrogen in a compound the overall magnetic moment of the compound tends to cancel out.

Further, we know that electrons do not travel like planets in circular orbits. So our model for magnetism is not really correct yet. To understand the current model of electron orbitals takes some quantum mechanics (and a few more years of physics). But we can understand a little, because quantum mechanics does tell us that the electrons have angular momentum. The big difference is that the angular momentum is *quantized* meaning it can have only certain values (think of the quantized modes of an oscillating string). The smallest magnetic moment for an electron turns out to be

$$\mu = \sqrt{2} \frac{q_e}{2m_e} \hbar \tag{26.2}$$

where

$$\hbar = \frac{h}{2\pi} = 1.05 \times 10^{-34} \text{ J s}$$

is pronounced “h-bar” and is a constant. We encountered Planck’s constant  $h$  before ( $h = 6.63 \times 10^{-34} \text{ J s}$ ). This is just Planck’s constant divided by  $2\pi$ . So it would seem that with only certain values being available the magnetic moments might be more likely to line up.

But it turns out that even in quantum mechanics, the magnetic moments of the electrons due to their orbits cancel each other out most of the time.

But there is another contribution to the magnetic moment, this time from the electron, itself. The electron has an amount of angular momentum. It is as though it spins on an axis. This spin angular momentum is also quantized. It can take values of

$$S = \pm \frac{\sqrt{3}}{2} \hbar \tag{26.3}$$

My mental picture of this is a charged ball spinning on an axis.

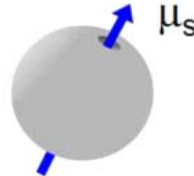

The magnetic moment due to spin is

$$\mu_s = \frac{q_e \hbar}{2m_e} \tag{26.4}$$

This means that electrons, themselves are little magnets. Where does this magnetic moment come from? Well it is *as though* the electron is constantly spinning. It is not really, but this is a semi-classical mental model that we can use to envision the source of the electron’s magnetic field. The “spinning” electron is charged, so the electron acts like a miniscule current loop. The electron, itself is a source of the magnetic field for permanent magnets.

The spin magnetic moment was given the strange name *Bohr magneton* in honor of Niels Bohr. If there are many electrons in the atom, there will be many contributions to the total atomic magnetic moment. The nucleus also has a magnetic moment (a detail we will not discuss) and there are other details like electron spin states pairing up. But those are topics for PH279 and our senior quantum mechanics class. But it turns out that this spin magnetic moment is the major cause that produces permanent magnetism. We don't want to wade through a senior level physics class now (well, you probably don't anyway) so we need a more macroscopic description of magnetism. But fundamentally, if we can get the electrons spins in a material to line up, we will have a magnet.

## Ferromagnetism

Question 223.42.3

Because of the spin magnetic moment, we can see some hope for how a permanent magnet might work. But these spin magnetic moments are also mostly randomly arranged. So again, most atoms won't have an overall magnetic moment. But some atoms do have a slight net field. They have an odd number of electrons. So the last electron can have an unbalanced magnetic moment. That atom would act as a magnet

Still, this does not produce much of an effect, because neighboring atoms all are oriented differently. So neighboring atoms cancel each other out. In a few materials, though, the atoms within small volumes will align their magnetic moments. These little domains form small magnets. But still the overall effect is very small because the domains are all oriented in different directions.

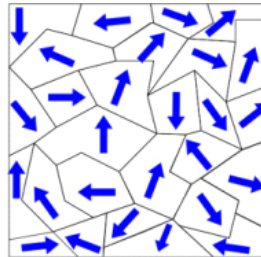

If we place these materials in a magnetic field, we can make the domains align, and then we have something!



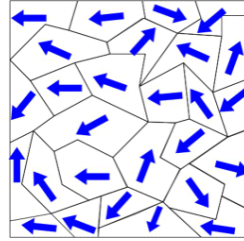

Few materials can do this. The ones that can are called ferromagnetic. Iron is one material. We can make the domains align, but the alignment decays quickly. That is why iron objects stick to a magnet, but don't stick to each other when they are taken away from the magnet. But if we can force the domains to stay in one direction, say, by heating the ferromagnetic metal in a magnetic field and letting it cool and form crystals, then we can make a magnet that will last longer. The magnetic moments will get stuck all pointing about the same direction as the ferromagnetic metal cools. Some materials like Cobalt form very long lasting permanent magnets.

## Magnetization vector

We now know that each atom of a substance may have a magnetic moment. For a block of the material, it is useful to think of the magnetic moment per unit volume. We will call this  $\mathbf{M}$ . It must be a vector, so that if there is an overall magnetic moment, we have a magnet! Let's see how to use this new quantity.

Suppose I have a current carrying wire that produces a field  $\mathbf{B}_o$ . But I also have a material where  $\mathbf{M}$  is not zero. Then there must be a field due to the magnetic material  $\mathbf{B}_m$ . So the total field will be

$$\mathbf{B} = \mathbf{B}_o + \mathbf{B}_m \quad (26.5)$$

and all we have to do is determine the relationship between  $\mathbf{B}_m$  and  $\mathbf{M}$ .

## Solenoid approximation

Lets look at two atoms, We will model them as little current loops, since they have magnetic moments.

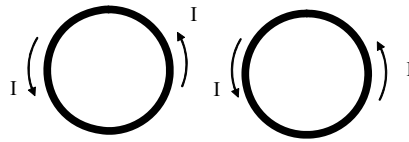

notice that in between the loops, the currents go opposite directions. We could think of them as canceling. We get a net current that is to the outside of the loops

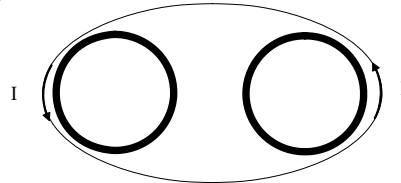

Now let's take many current loops.

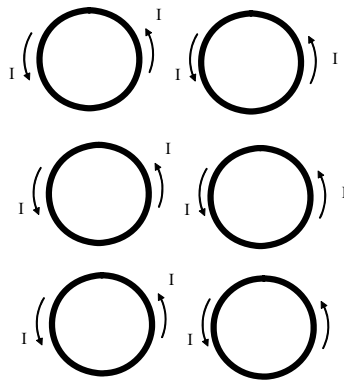

again, the inside currents cancel, leaving an overall current along the outside. Now if we view a material as a stack of such current loops

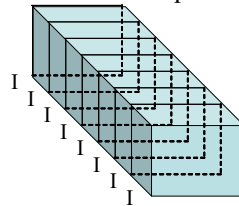

we can model a magnetic material like a solenoid! That is great, because we know how to find the field of a solenoid.

$$\begin{aligned}
 B_m &= \mu_o n I \\
 &= \mu_o \frac{N I A}{\ell A}
 \end{aligned}$$

I didn't cancel the  $A$ s because I want to recognize the numerator as the magnetic

moment

$$\mu = NIA$$

so

$$B_m = \mu_o \frac{\mu}{\ell A}$$

but note that  $\ell A$  is just the volume of the piece of magnetic material, so

$$B_m = \mu_o \frac{\mu}{V}$$

which gives us our new quantity, the magnetization vector

$$M = \frac{\mu}{V} \tag{26.6}$$

well, this is the magnitude, anyway, so

$$B_m = \mu_o M \tag{26.7}$$

and of course the directions must be the same, since  $\mu_o$  is just a scalar constant

$$\mathbf{B}_m = \mu_o \mathbf{M} \tag{26.8}$$

So the total field is given by

$$\mathbf{B} = \mathbf{B}_o + \mu_o \mathbf{M} \tag{26.9}$$

### Magnetic Field Strength (another confusing name)

Only do this if you have extra time

Sometimes we physicists just can't let things alone. So when we arrived at the equation

$$\mathbf{B} = \mathbf{B}_o + \mu_o \mathbf{M} \tag{26.10}$$

someone wanted to define a new term

$$\frac{\mathbf{B}_o}{\mu_o} \tag{26.11}$$

so we could write the equation

$$\mathbf{B} = \mu_o \left( \frac{\mathbf{B}_o}{\mu_o} + \mathbf{M} \right) \tag{26.12}$$

This new term is given an unfortunate name. The *magnetic field strength*. **It is not the magnitude of the magnetic field**, but is the magnitude divided by the constant  $\mu_o$ . It has it's own symbol, **H**. So you may write our total field equation as

$$\mathbf{B} = \mu_o (\mathbf{H} + \mathbf{M}) \tag{26.13}$$

You might find this change unnecessary and confusing (I do) but it is tradition to use this notation, and is not bad once you get used to it.

### Macroscopic properties of magnetic materials

We want a way to describe how “magnetic” different substances are without doing quantum mechanics. This will allow us to classify materials, and choose the proper material for whatever experiment or device we are designing.

For many substances we find that the magnetization vector is proportional to the field strength (which is why field strength hangs around in usage)

$$\mathbf{M} = \chi \mathbf{H} \quad (26.14)$$

For many materials, this nice linear relationship applies, and we can look up the constant of proportionality in a table. The name of the constant  $\chi$  is the *magnetic susceptibility*.

If  $\chi$  is positive ( $M$  is in the same direction as  $H$ ), we call the material *paramagnetic*.

If  $\chi$  is negative ( $M$  is in the opposite direction as  $H$ ), we call the material *diamagnetic*.

Using this new notation, our total field becomes

$$\mathbf{B} = \mu_o (\mathbf{H} + \mathbf{M})$$

$$\mathbf{B} = \mu_o (\mathbf{H} + \chi \mathbf{H})$$

$$\mathbf{B} = \mu_o (1 + \chi) \mathbf{H} \quad (26.15)$$

The quantity  $\mu_o (1 + \chi)$  is also given a name,

$$\mu_m = \mu_o (1 + \chi) \quad (26.16)$$

it is called the magnetic permeability. Now you see why  $\mu_o$  is called the permeability of free space! (the name was not so random after all!). If  $\chi = 0$  then

$$\mu_m = \mu_o \quad (26.17)$$

and this is the case for free space. We can write definitions of paramagnetism and diamagnetism in terms of the permeability.

Paramagnetic	$\mu_m > \mu_o$
Diamagnetic	$\mu_m < \mu_o$
Free Space	$\mu_m = \mu_o$

For paramagnetic and diamagnetic materials,  $\mu_m$  is usually not too different from  $\mu_o$  but for ferromagnetic materials  $\mu_m$  is much larger than  $\mu_o$ .

Note that we have not included ferromagnetic substances in this discussion. That is

because

$$\mathbf{M} = \chi\mathbf{H}$$

is not true for ferromagnetic materials.

Question 223.42.4

### Ferromagnetism revisited

But why is ferromagnetism different? To try to understand, let's take an iron toroid and wrap it with a coil as shown.

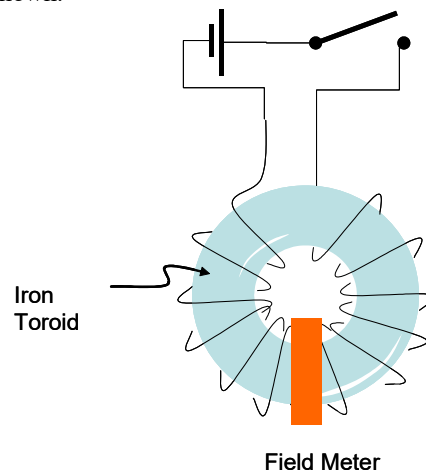

We have a magnetic field meter that measures the field inside the windings of the coil. When we throw the switch, the coil produces a magnetic field. The field will produce a magnetization vector in the iron toroid and, therefore, a field strength. We can plot the applied magnetic field vs. the field strength to see how much effect the applied field has on the magnetic properties of the iron toroid. We won't do this mathematically, but the result is shown in the figure.

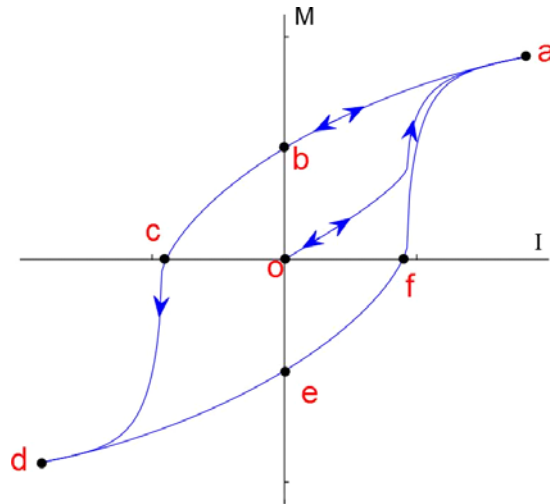

As we throw the switch, we go from no alignment of the domains so zero  $M$  and therefore zero induced field in the iron toroid to a value that represents the almost complete alignment of the magnetic moments of each atom of the iron. This is point  $a$ . It may take a bit of current, but in theory we can always do this. All the domains are aligned and  $M$  is maximum.

Now we reduce the current from our battery, and we find that the field due to the aligned domains drops as expected, but not along the same path that we started on! We go from  $a$  to  $b$  as the current decreases. At point  $b$  there is no current, but we still have a magnetic field in the toroid!

We can even keep going and reverse the field by changing the polarity of our power supply contacts. Since we still have some field in the toroid, it actually takes some reverse current to overcome the residual field. But if we apply enough reverse current, then we get alignment in the other direction. Almost complete alignment is at point  $d$ . If we again reduce the current and find that—once again—it does not retrace the same path!

Each time we align the domains with our applied external field from the coil, the domains in the iron toroid seem to want to stay aligned. Most do lose alignment, but some stay put. We have created a weak permanent magnet by placing our ferromagnetic material in a strong external magnetic field.

This strangely shaped curve is the *magnetization curve* for the material. The fact that the path is a strange loop instead of always following the same path is called *magnetic hysteresis*. We can see now that the external field (represented by the current  $I$ , since  $B_{\text{external}} \propto I$ ) and magnetization don't behave in a simple relationship like they did for

diamagnetic or permanganic materials.

The thickness of the area traced by the hysteresis curve depends on the material. It also represents the energy required to take the material through the hysteresis cycle.

If we add enough thermal energy, it is hard to keep the atomic dipole moments aligned. The next figure shows this effect.

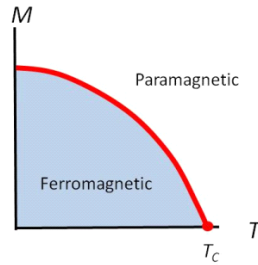

At a temperature called the Curie temperature, the material no longer acts ferromagnetic. It becomes simply paramagnetic. So if we heat up a permanent magnet, we expect it to lose its alignment and therefore to stop being a magnet. This is what happens to ferromagnetic materials when they are heated due to volcanism. The domains are destroyed and all the atoms lose alignment. When the material cools, the Earth’s magnetic field acts as an external field and some of the domains will be aligned with this field. This is how we know that the Earth’s magnetic field switches polarity. We can see which way the magnetization vector points in the cooled lava deposits from places like the Mid-Atlantic Trench.

This is also how magnetic tapes and disks work.

### Paramagnetism

So what is paramagnetism? It comes from the material having a small natural magnetic susceptibility.

$$0 < \chi \ll 1 \tag{26.18}$$

So in the presence of an external magnetic field, you can force the little magnetic moments to line up. You are competing with thermal motion as we saw in ferromagnetism, so the effect is usually weak. A rule of thumb for paramagnetism is that

$$M = C \frac{B_0}{T} \tag{26.19}$$

where  $C$  contains the particular material properties of the substance you are investigating (another thing to look up in tables in books),  $B_o$  the applied field, and  $T$  is the temperature. In other words, if it is cool enough, a paramagnetic material becomes a magnet in the presence of an external magnetic field. This is a little like polarization of neutral insulators in the presence of an electric field. For paramagnetic materials, the induced magnetic field is in the same direction as the external field.

Some examples of paramagnetic materials and their susceptibilities are given below

Material	Susceptibility
Tungsten	$6.8 \times 10^{-5}$
Aluminium	$2.2 \times 10^{-5}$
Sodium	$0.72 \times 10^{-5}$

### Diamagnetism.

This is fundamentally quite different from paramagnetism. It comes from the material having paired electrons that orbit the atom (classical model). The magnetic moments of the electrons will have equal magnitudes, but opposite directions (a little bit of quantum mechanics to go with our classical model). When the external field is applied, one electron's orbit is enhanced by the field, and the other is diminished (think  $q\mathbf{v} \times B$ ). So there will be a net magnetic moment. If you think about this for a while, you will realize that the new net magnetic moment is in the opposite direction of the applied external field! So diamagnetism will always repel.

There is always some diamagnetism in all mater. We can enhance the effect using a superconductor. The diamagnetism of the superconductor repels the external field entirely! Why does this happen only for superconductors? Well, that will take more theory to discover (a great topic for our junior level electrodynamics class). But the phenomena is called the Meissner effect.

Meissner effect  
demo

### Back to the Earth

So now we can see that the Earth is a magnet and we know how magnets are formed. But wait, why is the Earth a magnet? The real answer is that we don't know. But we believe that again it is because of current loops. We believe there is a current of ionized Nickel and Iron in near the center of the Earth. So the flow of these charged liquid metals will create a magnetic field. This is a vary large current loop! The evidence for



this is that magnetic field seems proportional to the spin rate of the planet. But this is an area of active research.

It is curious that the magnetic pole and the geographic pole are not in the same place. The magnetic pole also moves around like a precession. Then, every couple of hundred thousand years, the polarity of the Earth's field switches altogether!

There is still plenty of good research to do in this area.

The location of the magnetic pole explains the declination adjustment you have to use when using a compass. What you are really doing is accounting for the difference in pole location.

## Induced currents

Question 223.42.5 We spend most of the last two lectures building a relationship between moving charge (current) and magnetic fields. But suppose we have moving magnetic fields. Could a moving magnetic field make a current?

MIT 1edit.wmv If we think of relative motion, it seems like it should. After all, how do we know that it is the charge that is moving and not a moving  $B$ -field. In fact, moving  $B$ -fields *do* cause a current. We say that a moving or changing magnetic field *induces* a current.

Notice that in our movie, the current does not stay constant. As the magnet moves, we get a spike in current. But it drops back down to zero. When the magnet is taken away, again we get a spike in current (now the other direction). But again it dies back down. The current seems to exist only as the field changes, and there is more current where the field is changing fastest

Faraday discovered this effect. He described it as an *induced emf*. An emf is something that “pumps” the charges in the wire. It takes them from a lower to a higher potential so they can form a current. The changing magnetic field must be “pumping” the charges as it changes!

What is really going on here? Think for a minute what must be happening.

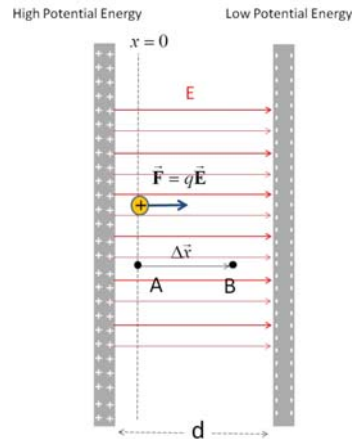

When we defined the electric potential, we use a capacitor. We found that there was a field directed from the + charges to the - charges. And in this field, charges had an amount of potential energy. When a current flows from the + end of the battery to the - end, there must be an electric field acting on the charge in the wire! That is what creates the electric potential. So, then, does a moving magnetic field create an electric field?

The answer is yes! We say that an electric field is *induced* by a moving magnetic field. This is really the same as saying that there is an induced emf for our current loop.

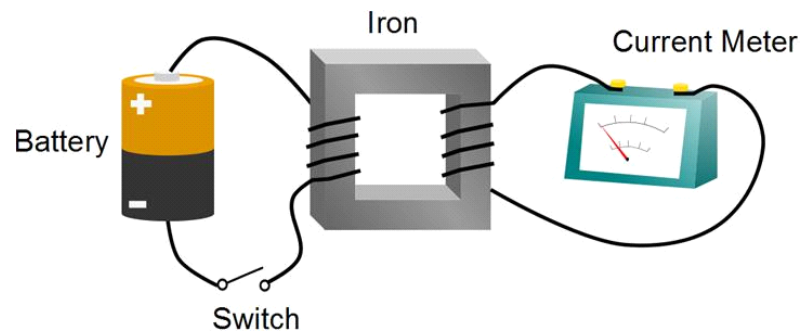

Faraday actually set up his experiment with two coils of wire. One coil was connected to a battery. We now know this coil will make a magnetic field. As the current starts flowing the field will form. While it is forming, it will induce an emf in the second coil. But this is just using an electromagnet instead of a permanent magnet.

To be able to calculate how much current flows, we will need to investigate changing magnetic fields. We will do this next lecture with our concept of flux.

## Basic Equations



# 27 Induction

## Fundamental Concepts

- Conductors moving in magnetic fields separate charge, creating a potential difference that we call “motional emf.”
- Motional emfs generate currents, even in solid pieces of conductor. These currents in conductors are called “eddy currents.”
- Magnetic flux is found by integrating the dot product of the magnetic field and a differential element of area over the area.  $\Phi_B = \int_A \vec{B} \cdot d\vec{A}$

## Motional emf

Last lecture, we studied Faraday’s experiment. He created a magnetic field, and then used that magnetic field to make a current. But currents are caused by electric fields! Did Faraday’s magnetic field create an electric field?

To investigate Faraday’s result, let’s see if we can find a way to use charge motion and a magnetic field to make an electric field. Let’s take a bar of metal and move it in a magnetic field. The bar has free charges in it (electrons). We have given them a velocity. So we expect a magnetic force

$$\vec{F}_B = q\vec{v} \times \vec{B}$$

The free charges will accelerate together, but the positive stationary charges can’t move. We have found another way to separate charge. We know that separated charge creates a potential difference. We often call this induced potential difference the *motional emf* because it is created by moving our apparatus.

Let’s take an example to see how it works.

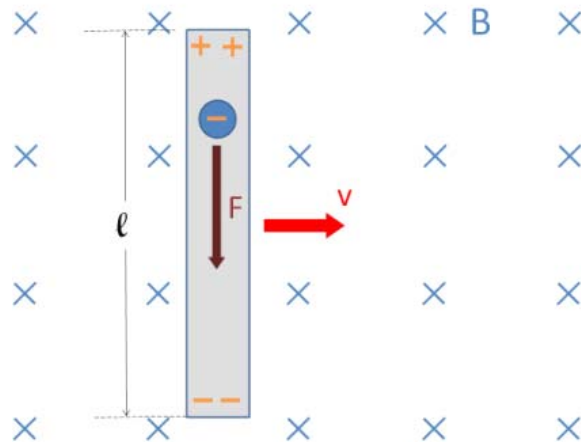

For this example, let's look at a piece of wire moving in a constant field. To make the math easy, let's move the wire with a velocity perpendicular to the  $B$ -field.

As the figure shows, the electrons will feel a force. Using our right hand rule, we get an upward force for positive charge carriers, but we know the electrons are negative charge carriers, so the force is downward. We find that the magnitude of the force is

$$F_B = qvB$$

The electrons will bunch up at the bottom of the piece of wire, until their electric force of repulsion forces them to stop. That force is

$$F_E = qE$$

By separating the charges along the wire, we now have an  $E$ -field. We can solve for  $E$  when we have reached equilibrium.

$$\Sigma F = 0 = -F_B + F_E$$

or

$$qE = qvB$$

which tells us

$$E = vB \quad (27.1)$$

Now, we know that electric fields cause potential differences. The  $E$ -field in the wire will be nearly uniform. Then it looks much like a capacitor with separated charges. The potential difference will be

$$\begin{aligned} \Delta V &= \int \vec{E} \cdot d\vec{s} \\ &\approx EL \end{aligned}$$

where  $L$  is the length of our wire. So

$$\Delta V \approx vBL \tag{27.2}$$

This is like a battery. The magnetic field is “pumping” charge. If we connected the two ends somehow with a wire that is not moving, a current will flow (that is tricky to actually do!).

Question  
223.43.0.1

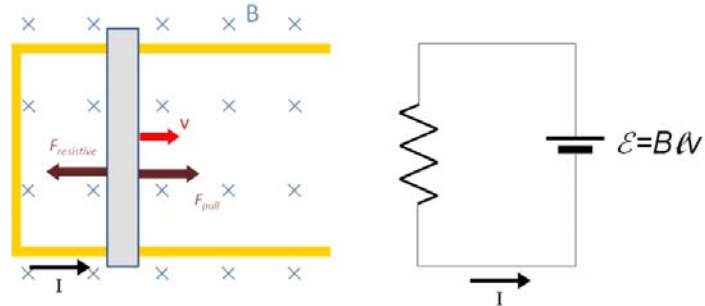

Let’s take another example. We wish to make a bar of metal move in a  $B$ -field. To make the rest of the circuit, we allow the bar to slide along two wires as shown. We will call the two wires “rails” since they look a little like railroad rails. Then we have a connection between our moving piece of metal, and the rest of the circuit. What we have is very like the circuit on the right hand side of the last figure.

We will have to apply a force  $F_{pull}$  to move the bar. This is because there is another force, marked as  $F_{resistive}$  in the figure. This force is one we know, but might not recognize unless we think about it. We now have a current flowing through a wire, and the wire is in a magnetic field. So there will be a force

$$\begin{aligned} F_{resistive} &= I \vec{L} \times \vec{B} \\ &= ILB \sin \theta \\ &= ILB \end{aligned}$$

pushing to the left. This force resists our pull.

From Ohm’s law, the current in the wire will be

$$\begin{aligned} I &= \frac{\Delta V}{R} \\ &= \frac{vBL}{R} \end{aligned}$$

so the force is

$$\begin{aligned} F_{resistive} &= \left( \frac{vBL}{R} \right) LB \\ &= \frac{vB^2L^2}{R} \end{aligned}$$

Thus we have to push with an equal force

$$F_{push} = F_{resistive}$$

to keep the bar moving along the rails. If  $F_{push} < F_{resistive}$  then the bar will have an acceleration, and it will be in the opposite direction from the velocity, so the bar will slow down.

## Eddy Currents

Question 223.43.1

Pendulum-loop

So if we have a conductive loop and part of that loop moves in a magnetic field, we get a current. I chose to make our apparatus a pendulum.

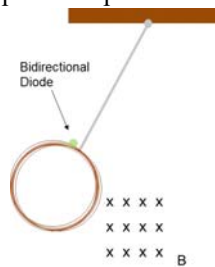

So as the pendulum swings, through the magnetic field, we get a current. What if we have a solid sheet of conductor and we move that sheet through the magnetic field, will there be a current?

Pendulum-plate

Question 223.43.2

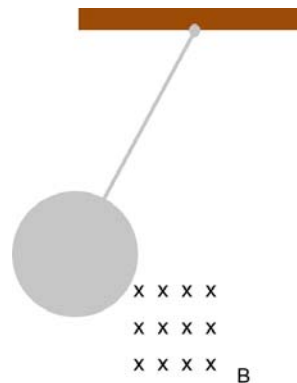

The answer is yes. We call this current an *eddy current*. Let's see that this must be true with another experiment. Let's cut grooves in the plate.

Question 223.43.3





Al plate and strong magnets

Floating Plate Demo

The current is broken by the grooves, so there is little opposing magnetic field. This effect due to the eddy currents is often used to slow down machines. Rotating blades, and even trains use this effect to provide braking.

## Magnetic Flux

Remember long ago we defined the electric flux.

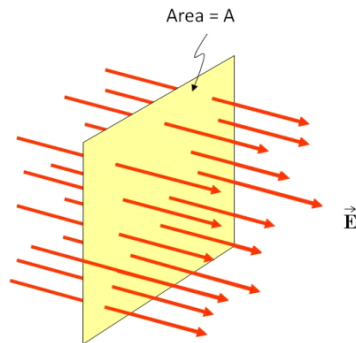

Recall that the electric flux is given by

$$\begin{aligned} \Phi_E &= \vec{E} \cdot \vec{A} \\ &= EA \cos \theta \end{aligned}$$

But we now have a magnetic field.

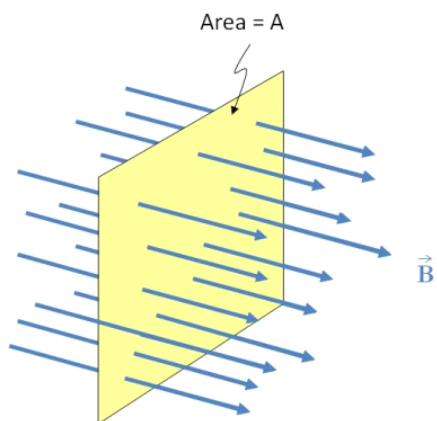

We define a magnetic flux

$$\Phi_B = \vec{B} \cdot \vec{A} \quad (27.3)$$

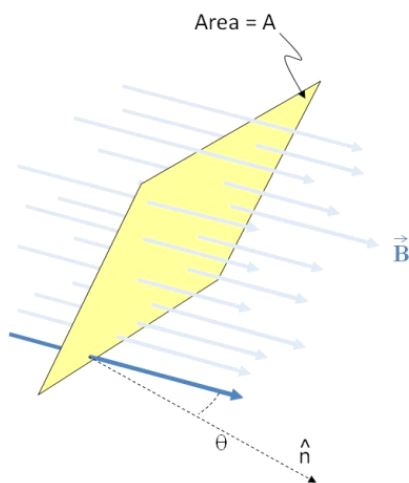

$$\Phi_B = BA \cos \theta \quad (27.4)$$

where  $\theta$  is the angle between  $\vec{B}$  and  $\vec{A}$ .

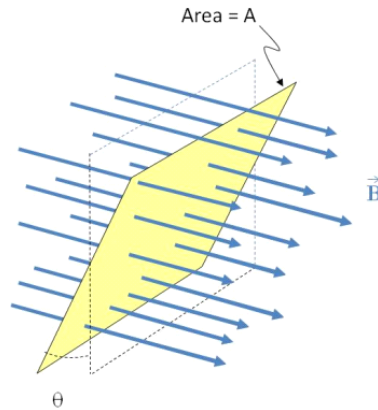

We found that the electric flux was very useful. We used Gauss' law to find fields using the idea of electric flux. It turns out that this magnetic flux is also a very useful idea. There is a difference, though. With electric fluxes, we had imaginary areas that the field penetrated. Often when we measure magnetic flux, we actually have something at the location of our area. We generally want to know the flux through a wire loop.

Just like with electric flux, we expect the flux to be proportional to the number of field lines that pass through the area.

## Non uniform magnetic fields

So far in this lecture we have only drawn uniform magnetic fields and considered their flux. But we can easily imagine a non-uniform field. We tackled non-uniform electric field fluxes. We should take on non-uniform magnetic field fluxes as well. Suppose we have the situation shown in the following figure.

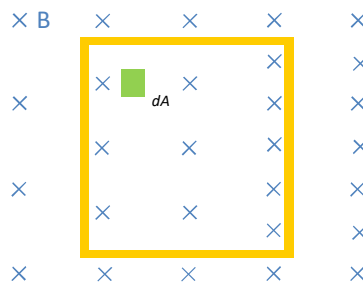

We have a loop of wire, and the loop is in a flux that changes from left to right.

To find the flux through such a loop of wire, we can envision a small element of area,

$d\vec{A}$  as shown. The flux through this area element is

$$d\Phi_B = \vec{B} \cdot d\vec{A}$$

We can integrate this to find the total flux

$$\Phi_B = \int_A \vec{B} \cdot d\vec{A} \tag{27.5}$$

But what could make such a varying  $B$ -field? Consider a long straight wire again.

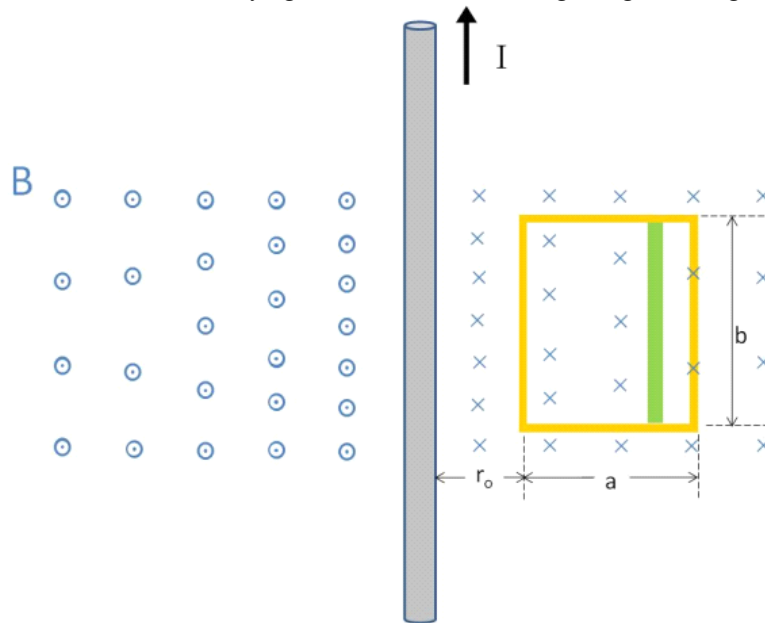

We know that the field due to the current-carrying wire will be

$$B = \frac{\mu_0 I}{2\pi r}$$

where  $r$  is the distance from the wire and the direction is given by one of our right hand rules.

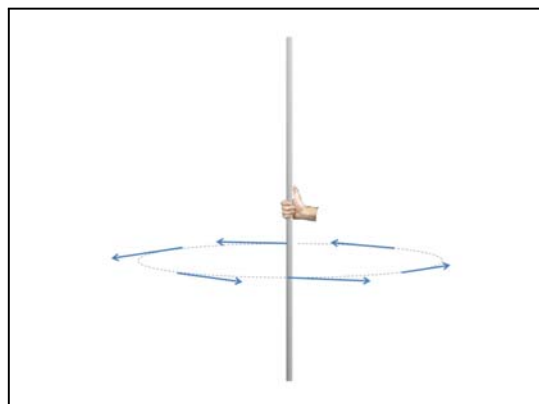

Question 223.43.4

The flux through the green rectangular area is almost constant. The little area is given by

$$dA = dydr$$

The area is perpendicular to the field, so the angle between  $B$  and  $A$  is  $90^\circ$ . Then

$$d\Phi_B = \frac{\mu_o I}{2\pi r} b dr \quad (1)$$

and we can integrate this to find the total flux

$$\begin{aligned} \Phi_B &= \int_{r_o}^{r_o+a} \int_0^b \frac{\mu_o I}{2\pi r} dy dr \\ &= \frac{\mu_o I b}{2\pi} \int_{r_o}^{r_o+a} \frac{1}{r} dr \\ &= \frac{\mu_o I b}{2\pi} (\ln(r_o + a) - \ln(r_o)) \\ &= \frac{\mu_o I b}{2\pi} \ln\left(\frac{r_o + a}{r_o}\right) \end{aligned}$$

We can even put in some numbers for this case. Suppose our loop has a height of  $b = 0.05$  m and a width of  $a = 0.01$  m and that it is a distance  $r_o = a$  away from the current carrying wire and that the current is  $I = 0.5$  A. Then

$$\begin{aligned} \Phi_B &= \frac{(4\pi \times 10^{-7} \frac{\text{T}\cdot\text{m}}{\text{A}}) (0.5 \text{ A}) (0.05 \text{ m})}{2\pi} \ln\left(\frac{0.01 \text{ m} + 0.01 \text{ m}}{0.01 \text{ m}}\right) \\ &= 3.4657 \times 10^{-9} \text{ Wb} \end{aligned}$$

the unit of magnetic flux is called the weber and it is given by :

$$\text{Wb} = \text{T m}^2 = \frac{\text{m}^2 \text{ kg}}{\text{A s}^2}$$

We know now how to calculate magnetic flux, but you should expect that we can do something with this flux to simplify problems. And your expectation would be right. We used electric flux in Gauss' law. We will use magnetic flux to find the induced emf. An induced emf can create a current, and this is the basic idea behind a generator. The law that governs this relationship between induced emf and magnetic flux is called *Faraday's law* after the scientist that discovered it. We will study this law in our next lecture.

## Basic Equations



# 28 Faraday and Lenz

## Fundamental Concepts

Question 223.44.1

Question 223.44.2

Question 223.44.3

We talked about an induced electric field created by a magnetic field last lecture. We want to formalize that relationship in this lecture. Let's go back to our motional emf problem.

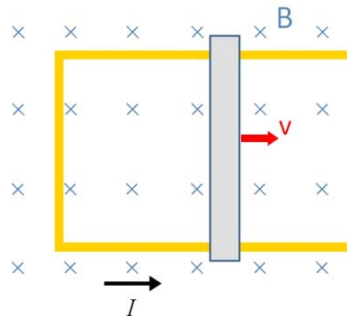

We have a sliding bar, and a u-shaped conductor and a magnetic field. The moving bar makes the current flow. But now we know another way to express this. We can see that there is a magnetic flux through the loop consisting of the u-shaped conductor and the sliding bar. This flux going through the loop is changing. The area is getting larger, so the amount of field going through the loop is increasing. We can say the induced current is due to the changing loop area in the presence of the magnetic field, or a changing magnetic flux.

An important thing we learned is that the moving bar feels a resistive force due to the current and magnetic field. It seems like the magnetic field and current are resisting any change in our set up. We will see in this lecture that this is true in general.

It turns out that there is more than one way to cause an induced current. Any change in the magnetic flux is found to make a current flow. Remember in class we found that putting a magnet into or pulling the magnet out of a coil makes a current. In this case, the strength of the magnetic field changes, so the flux changes. Really any change in

magnetic flux makes a current flow.

### Fundamental Concepts in the Lecture

- Changing magnetic flux makes an electric field—which has an associated potential difference or emf.
- The current caused by the induced emf travels in the direction that creates a magnetic field with flux opposing the change in the original flux through the circuit.
- The emf (potential difference) generated by a changing magnetic field is given by  $\mathcal{E} = -N \frac{\Delta \Phi_B}{\Delta t}$

### Lenz

What we are saying is that if we change the magnetic flux through a loop, we will get a current. The direction of current flow is not obvious. Lenz experimentally determined which way it will go. Here is his rule

---

The current caused by the induced emf travels in the direction that creates a magnetic field with flux opposing the change in the original flux through the circuit.

---

This takes a moment to digest. Let's take an example

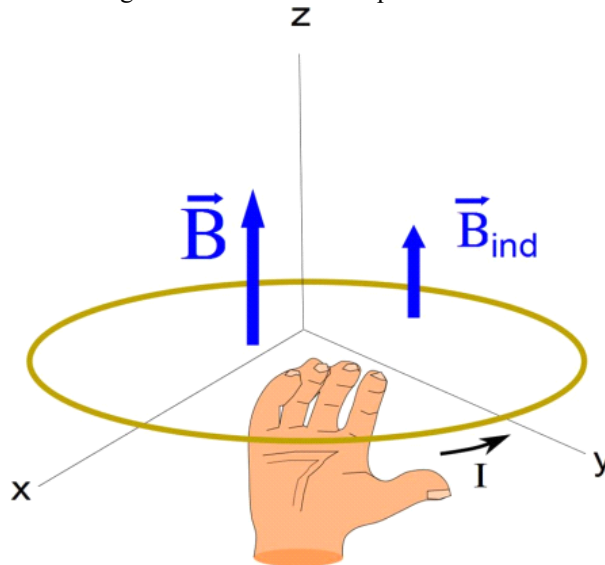

Consider the case shown in the picture. Suppose the  $B$ -field gets smaller in time. If that is the case, then the induced current will try to keep the same number of field lines



Question 223.44.4 -  
223.44.11

going through the loop. To do this, it will have to add field lines, because our field that is getting smaller will have fewer and fewer field lines. So in this case, the induced field  $\vec{B}_{ind}$  will be in the same direction as  $\vec{B}$  to try to keep the number of field lines the same. We find the current using our current-carrying wire right hand rule for magnetism. We imagine grabbing the wire such that our fingers curl into the loop the way  $\vec{B}_{ind}$  goes through the loop. Then our thumb is in the direction of the current.

## Faraday

In our motional emf problem, the sliding bar in the magnetic field creates a potential difference,  $\Delta V$ . It becomes an emf. We can use the symbol  $\mathcal{E}$  for our emf.

But then in considering Lenz's law, it was experimentally found that any change in  $\Delta \Phi_{ux}$  causes a current. Then any change in  $\Delta \Phi_{ux}$  must create an emf.

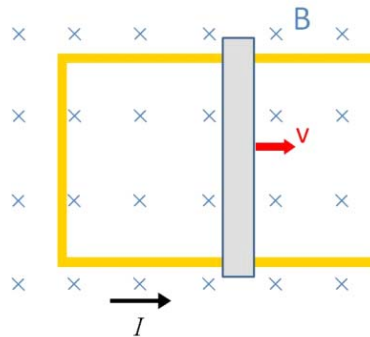

In this case the area is getting larger, and so the  $\Delta \Phi_{ux}$  is getting larger. The induced current will oppose the change. So the induced magnetic field should go up through the center of the loop. Imagine sticking your fingers through the loop out of the page, then grabbing the loop (fingers still out of the page in the inside of the loop). Anywhere you grab the wire, your thumb is in the induced current direction.

## Faraday's law of Magnetic Induction

Faraday wrote an equation to describe the emf that was given by changing a  $B$ -field. It combines what we know about magnetic  $\Delta \Phi_{ux}$  and current from Lenz's law. Faraday did not know the source of the emf, it is a purely empirical equation. Here it is

$$\mathcal{E} = -N \frac{\Delta \Phi_B}{\Delta t} \quad (28.1)$$

The  $N$  is the number of turns in the coil (remember he used a coil, not just one loop).  $d\Phi_B$  is the change in the magnetic flux. Our definition of magnetic flux is

$$\Phi_B = \int \vec{\mathbf{B}} \cdot d\vec{\mathbf{A}}$$

but for simple open surfaces we can gain some insight by writing the flux as

$$\Phi_B = BA \cos \theta$$

Then the induced emf would be given by

$$\mathcal{E} = -N \frac{(B_2 A_2 \cos \theta_2 - B_1 A_1 \cos \theta_1)}{\Delta t} \quad (28.2)$$

and we see that we get an emf if  $B$ ,  $A$ , or  $\theta$  change. We can write this as a differential if we let  $\Delta t$  get very small.

$$\mathcal{E} = -N \frac{d\Phi_B}{dt} \quad (28.3)$$

Suppose we have a simple flux  $\Phi_B = \vec{\mathbf{B}} \cdot \vec{\mathbf{A}}$ , then for this simple case

$$\begin{aligned} \mathcal{E} &= -N \frac{d}{dt} (\vec{\mathbf{B}} \cdot \vec{\mathbf{A}}) \\ &= -N \left( \vec{\mathbf{B}} \cdot \frac{d\vec{\mathbf{A}}}{dt} + \vec{\mathbf{A}} \cdot \frac{d\vec{\mathbf{B}}}{dt} \right) \end{aligned}$$

The first term shows our motional emf case. The area is changing in time. But the second term shows that if the field changes, we get an emf. This is the moving magnet in the coil case.

There are some great applications of induced emfs, from another design for circuit breakers to electric guitar pickups!

Question 223.44.12  
- Question  
223.44.17

## Return to Lenz's law

Remember that Lenz's law says the current caused by the induced emf travels in the direction that creates a magnetic field with flux opposing the change in the original flux through the circuit. What if the current went the other way?

If that happened, then we could set up our bar on the rails, and give it a push to the right. With the current going down instead of up (for positive charge carriers) then we

would have a force on our bar-like segment of wire

$$F_I = BIL \sin \phi$$

here  $\sin \phi = 1$  so

$$F_I = BIL$$

It will be directed to the right. So the bar would accelerate to the right. That would increase the size of the loop, increasing the current. That would increase the force to the right, and our bar would soon zip off at amazing speed. But that does not happen. It would take ever more energy to make the bar go faster, with no input energy. So this would violate conservation of energy. Really Lenz's law just gives us conservation of energy again.

### Pulling a loop from a magnetic field.

Let's try a problem. Suppose we have a wire loop. The loop is rectangular, with side lengths  $\ell$  and  $x$ . Further suppose that the loop is in a region with magnetic field, but that it is on the edge of that field, so that if we pull it to the right, it will leave the field.

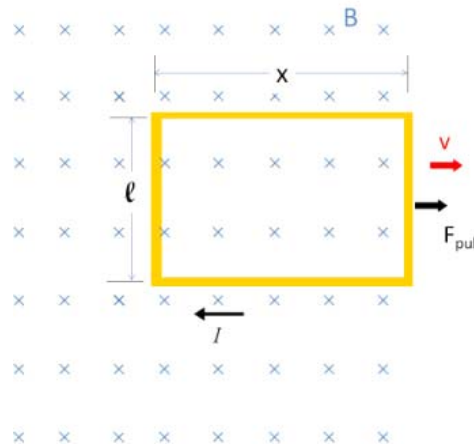

let's see if we can find the induced emf and current.

The Magnetic flux through the loop is changing. We can find an expression for the flux

$$\Phi_B = \vec{B} \cdot \vec{A}$$

or in this case

$$\Phi_B = B\ell x$$

We know the emf from Faraday's law

$$\mathcal{E} = -N \frac{d\Phi_B}{dt}$$

then

$$\mathcal{E} = -(1) \frac{d}{dt} (B\ell x)$$

The field is not changing strength, and the length  $\ell$  is not changing. But along the  $x$  side, we are losing field. Remember that  $A$  in our  $\square$ ux equation is the area that actually has field and we have less area that has field all the time. We can see that

$$\mathcal{E} = -(1) \frac{d}{dt} (B\ell x) = -B\ell \frac{dx}{dt} = -B\ell v$$

where  $v$  is the speed at which we are pulling the wire loop. That is the speed at which our  $\square$ ux changes.

We can use Ohm's law to find the current,

$$I = \frac{\Delta V}{R} = \frac{\mathcal{E}}{R}$$

or

$$I = \frac{B\ell v}{R}$$

We could ask, how much work does it take to pull the wire out of the field? This is like our capacitor problem where we pulled a dielectric out of the middle of the capacitor.

The net force on the loop is not zero, because the field is no longer uniform. The right hand side of the loop is outside the field, and the left hand side is not. Of course, the top and bottom of the loop have opposite forces that balance each other. So the net force is due to the left hand side of the loop. Recall that

$$\vec{\mathbf{F}} = I \vec{\mathbf{L}} \times \vec{\mathbf{B}}$$

We can see that in this case  $I$  is upward, and  $B$  is into the page. So there is a force to the left resisting our change  $\square$ ux. We must pull to overcome this force. The magnitude of this force is

$$F = I\ell B$$

and we know  $I$  so

$$F = \frac{B\ell v}{R} \ell B = \frac{B^2 \ell^2 v}{R}$$

Now we need to find the work done.

$$W = \int F dx$$

or, since our force will be constant,

$$W = F \int dx$$

which is not a hard integral to do. But instead of performing the integral, let's look at the integrand.

$$dW = F dx$$

if we divide both sides of our equation by  $dt$  we have

$$\frac{dW}{dt} = F \frac{dx}{dt}$$

we know that  $P = dW/dt$  and  $\frac{dx}{dt} = v$  and so we can write our equation as

$$\begin{aligned} P &= Fv \\ &= \frac{B^2 \ell^2 v^2}{R} \end{aligned}$$

which is how much power the magnetic field force provides in resisting. We must provide an equal power to move the loop. It will take time

$$\Delta t = \frac{\Delta x}{v}$$

to pull the loop a distance  $\Delta x$ . If we define our coordinates such that  $x_i = 0$  then to pull out the loop, we will write this time as

$$\Delta t = \frac{x}{v}$$

so the work is

$$\begin{aligned} W &= P \Delta t \\ &= \frac{B^2 \ell^2 v^2}{R} \frac{x}{v} \\ &= \frac{B^2 \ell^2 x v}{R} \end{aligned}$$

Incidentally, we learned from our demonstrations that induced currents can take energy out of a system, creating heat energy. From Ohm's law the power lost due to resistive heating would be

$$\begin{aligned} P &= I^2 R \\ &= \left( \frac{B \ell v}{R} \right)^2 R \\ &= \frac{B^2 \ell^2 v^2}{R} \end{aligned}$$

which is just the power we had to provide to make our loop move. So our work has moved the loop and heated up the wire.

We have created a current in a wire. This is the first step in building a generator. It cost us work to do this. In the next lecture, we will tackle more practical design and build generators and transformers. Then we will pause to think philosophically about what it means that a changing magnetic flux creates an electric field.

## Basic Equations



# 29 Induced Fields

## Fundamental Concepts

- Changing the commutator for slip rings makes a motor into a Generators
- Using alternating current, we can build an inductive device that can change from one voltage to another. This device is called a transformer.
- A more general form of Faraday's law is  $\int \mathbf{E} \cdot d\mathbf{s} = -\frac{d\Phi_B}{dt}$

## Generators

Question 223.45.1

Whether you are just plugging in an appliance, or preparing for an emergency, you likely would think of a generator as a source of electrical energy. Our studies so far have strongly hinted on how we would build an electric generator. In this lecture, we will fill in the details.

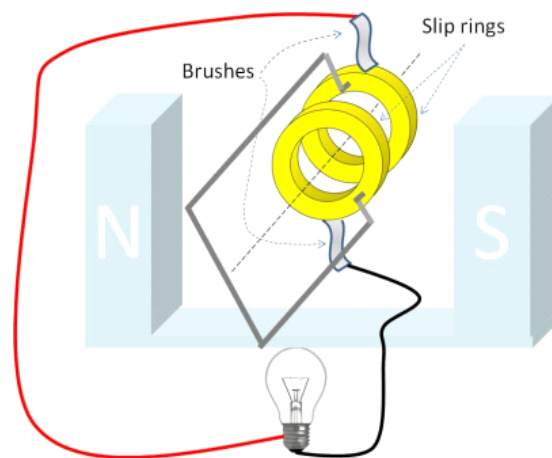

We can learn a lot by studying this device as an example. The figure shows the important parts of the generator (and a light bulb, which is not an important part of a generator, but just represents some device that will use the electrical current we make).

The generator has at least one magnet. In the figure, there is one with a north end on the left and a south end on the right. A generator also has a wire loop. Usually in real generators, there are thousands of turns of wire forming the loop. In our picture, there is just one. The wire loop is connected to two metal rings. The rings will turn as the loop turns. Metal contacts (brushes) that can slip along the rings, but maintain an electrical connection, are placed on the rings. So as the rings turn, current can still flow through the connected wires (to the light bulb in this case).

Question 223.45.2

This should look familiar. This is the same basic setup as the motor, with a few exceptions. An important exception is that the commutator has been replaced by the set of rings. We will call these ring contacts *slip rings* because the wires can slip along them while still maintaining electrical contact because of the brushes. We have a current loop in a (nearly) uniform, constant field. If I look from the slip ring side of the loop, I have the same geometry we had before when we considered motors. This time I want to consider doing work to turn the loop, and find the induced emf in the loop. We start with Faraday's law

$$\mathcal{E} = -N \frac{d\Phi_B}{dt} \tag{29.1}$$

since in our special case we only have one loop, this is just

$$\mathcal{E} = - \frac{d\Phi_B}{dt} \tag{29.2}$$

Here is a the view looking at the cross section of the loop facing toward the slip rings.

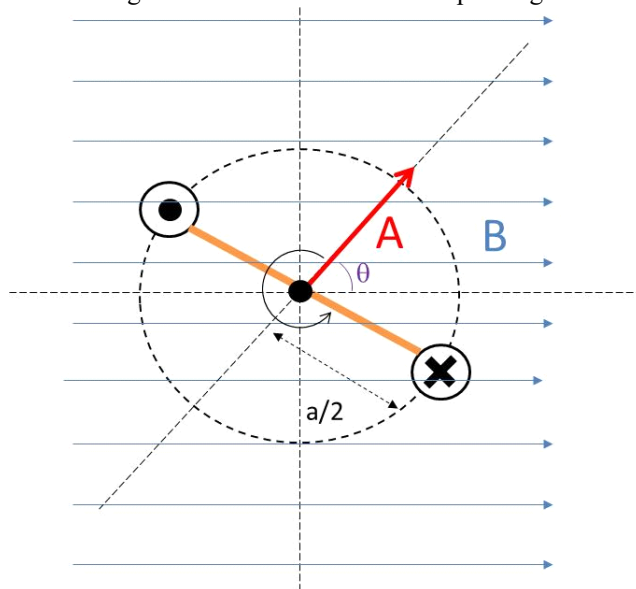



Let's consider the flux through the loop. The definition we have for flux is

$$\begin{aligned}\Phi_B &= \mathbf{B} \cdot \mathbf{A} \\ &= BA \cos \theta \\ &= BA_{proj}\end{aligned}$$

where  $\theta$  is the angle between the loop area vector and the magnetic field direction.

I want to write the flux in terms of the lengths of the wire. When the loop is standing up straight along the  $y$ -direction the projected area is just the area

$$A = \ell a$$

Then the projected area is

$$A_{proj} = \ell a \cos \theta$$

Let's check to make sure this works. When the loop is standing up straight along the  $y$ -direction  $\theta = 0^\circ$ , and  $\cos \theta = 1$  so

$$A_{proj \max} = \ell a \cos \theta = \ell a$$

so this works.

To find the emf generated, I need

$$\mathcal{E} = -\frac{d\Phi_B}{dt}$$

and only the projected area is changing (really, only the angle is changing). So

$$\mathcal{E} = -\frac{d\Phi_B}{dt} = -B \frac{dA_{proj}}{dt}$$

We realize that  $\theta$  must change in time. We remember from PH 121 or Dynamics that we can use  $\theta = \omega t$  where  $\omega$  is the angular speed of the rotating loop. Then

$$A_{proj} = \ell a \cos \omega t$$

and

$$\mathcal{E} = -\frac{d\Phi_B}{dt} = -B \frac{d}{dt} \ell a \cos \omega t$$

We recognize that  $\theta$  changes as the loop turns. Since  $B$  is not changing, the change in flux per unit time is just  $B$  times the change in area with time.

$$\mathcal{E} = B\ell a \omega \sin(\omega t)$$

Look at what we got! it is a sinusoidal emf. This will make a sinusoidal current!

$$\begin{aligned}I &= \frac{\mathcal{E}}{R} \\ &= \frac{B\ell a \omega \sin(\omega t)}{R}\end{aligned}$$

for a circuit. Our emf looks like

$$\mathcal{E} = \mathcal{E}_{\max} \sin(\omega t) \quad (29.3)$$

where

$$\mathcal{E}_{\max} = Bl\omega \quad (29.4)$$

Here is a plot of the function

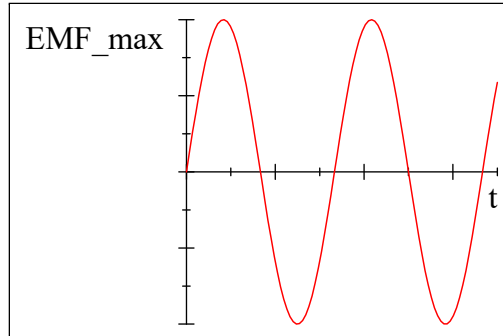

Of course this sinusoidal emf will create what we call an *alternating current*. This is how the current in the outlets in your house is generated.

Of course, our generator only has one coil. Actual generators have multiple coils.

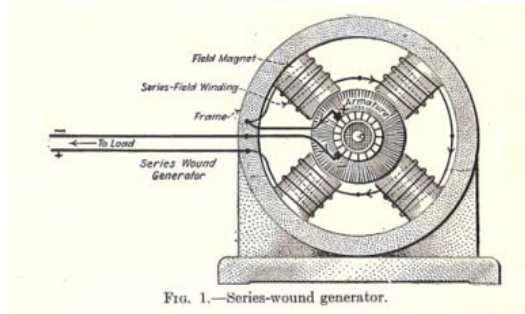

Double Armature Generator (Public Domain Image)

and we need a source of work to turn the generator. A water turbine is an example,

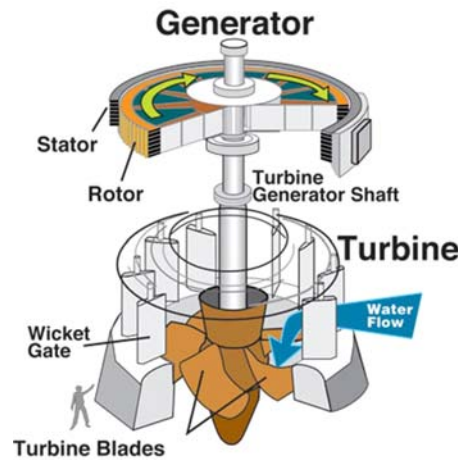

Water Turbine driven Generator (Public Domain Image courtesy U.S. Army Corps of Engineers)

or for emergencies, you might have a gasoline powered generator, or in a nuclear reactor you might have a steam driven generator. Still, the basic idea of a wire loop moving relative to a magnetic field is common to all electric generators.

## DC current from a generator

We can also make a non-alternating current with a generator, but we have to get tricky to do it. We use the same idea we used to make a motor. We cut slots in the slip rings, so the current will switch directions every half turn. We get a kind of poor quality current from this because the emf still varies a lot.

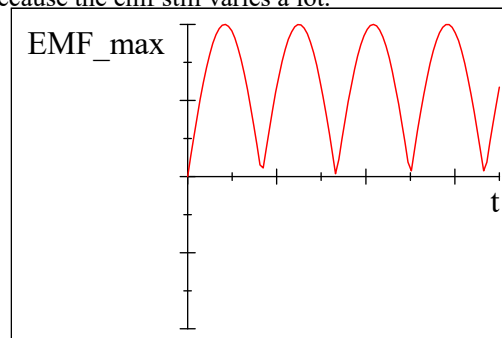

Clever engineers design generators for non-alternating or *direct current* generators by overlapping several current loops at different angles. Each loop has its own cut slip rings. The combined currents smooth out the ripples we see in the previous figure. For semiconductor devices, special circuits are used to make the current very smooth.

## Back emf

We can see that a motor is a DC generator run backwards. I just want to mention that when we talk about motors, we have to realize that as we send current into the motor coils, there will be an induced emf that will try to maintain the existing  $\Phi_{\text{ux}}$  as the motor's loops turn. This emf will be in the opposite direction of the applied current! So it reduces the amount of work the motor can do. This is like the resistive force we encountered when we pulled a loop from a magnetic field last lecture. This resistive force is called the *back emf* and must be accounted for in motor design.

## Transformers (not the movie)

Question 223.45.3

The power comes into our houses at about 120V. Your iPhone probably requires 3 V to 5 V. How do we get the voltage we want out of what the power company delivers? You know the answer is to plug in your phone using a special adaptor. Lets see how it works.

Let's consider Faraday's law again. We know that

$$\mathcal{E} = \Delta V(t) = -N \frac{d\Phi}{dt}$$

Suppose we use Faraday's idea and hook two coils up next to each other.

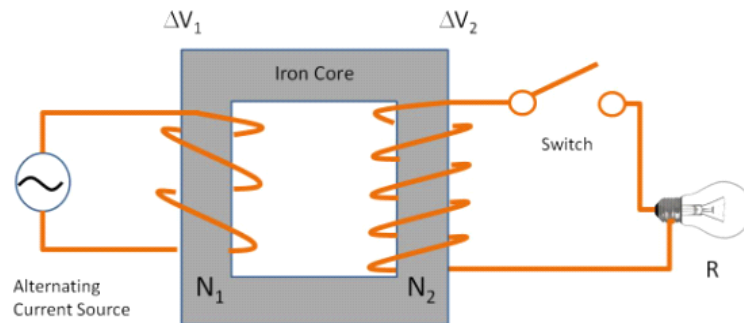

One side we will hook to an alternating emf. We will call this side coil 1. The other side we will hook a second coil with some resistive load like a light bulb. We will call this coil 2. The iron core keeps the magnetic field inside, so the  $\Phi_{\text{ux}}$  through coil 1 ends up going through coil 2. (think of all the little domains in the iron lining up along the field lines, and enhancing the field lines with their own induced fields).

The alternating potential from the source will create a change in  $\Phi_{\text{ux}}$  in coil 1.

$$\Delta V_1 = -N_1 \frac{d\Phi_1}{dt}$$

if little  $\Phi_{\text{ux}}$  is lost in the iron, then we will retrieve most of the  $\Phi_{\text{ux}}$  in coil 2 and an emf will be induced in the resistor (light bulb in our case).

$$\Delta V_2 = -N_2 \frac{d\Phi_2}{dt}$$

we just convinced ourselves that

$$\frac{d\Phi_1}{dt} \approx \frac{d\Phi_2}{dt}$$

so we can solve each equation for the change in  $\Phi_{\text{ux}}$  term, and set them equal.

$$\begin{aligned} \frac{\Delta V_1}{N_1} &= -\frac{d\Phi_1}{dt} \\ \frac{\Delta V_2}{N_2} &= -\frac{d\Phi_2}{dt} \end{aligned}$$

so we have

$$\frac{\Delta V_1}{N_1} = \frac{\Delta V_2}{N_2} \tag{29.5}$$

If we solve for  $\Delta V_2$  we can find the emf in coil 2.

$$\frac{N_2}{N_1} \Delta V_1 = \Delta V_2 \tag{29.6}$$

Question 223.45.4

You have probably already guessed how we make  $\Delta V_2$  to be some emf amount we want. We take, say, our wall current that has a value<sup>18</sup> of  $\Delta V_1 = 120 \text{ V}$ . We pass it through this device we have built. We design the device so that  $\frac{N_2}{N_1} \Delta V_1$  gives just the potential that we want for  $\Delta V_2$ . If we want a lower emf, say  $12 \text{ V}$ , then we make  $\frac{N_2}{N_1} = 0.1$  so

$$\frac{N_2}{N_1} \Delta V_1 = 0.1 (120 \text{ V}) = 12 \text{ V} \tag{29.7}$$

This is part of what the wall adaptor does. Usually wall adaptors also have some circuitry to make the alternating current into direct current.

Note that there is a cost to doing this. The power must be the same on both sides (or a little less on side 2). So

$$\mathcal{P}_{av} = I_{1,rms} \Delta V_{1,rms} = I_{2,rms} \Delta V_{2,rms}$$

We can change the emf, but it will effect our ability to supply current.

This device is called a transformer. Real transformers do lose power. Some loss is due to the fact that not all the  $B$ -field from coil 1 makes it inside coil 2. But real transformers are not too bad with efficiencies ranging from 90% to 99%.

Question 223.45.5

## Induced Electric Fields

Consider again a magnetic field and a moving charge. If the field changes, the  $\Phi_{\text{ux}}$

<sup>18</sup> Really this should be an rms voltage, but we have not studied alternating current yet, so for now we will just call it a voltage.

changes. Say, for example, that the field is increasing in strength.

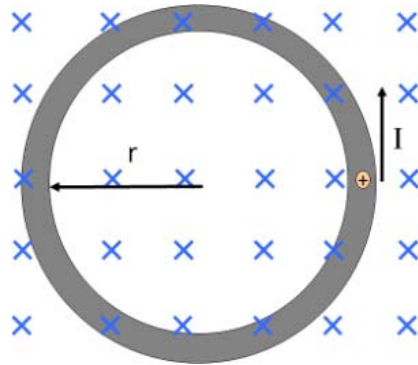

The charge will move in a circle within the wire. We now understand that this is because we have induced an emf. But think again about a battery.

The battery makes an electric field inside a wire. Recall this figure

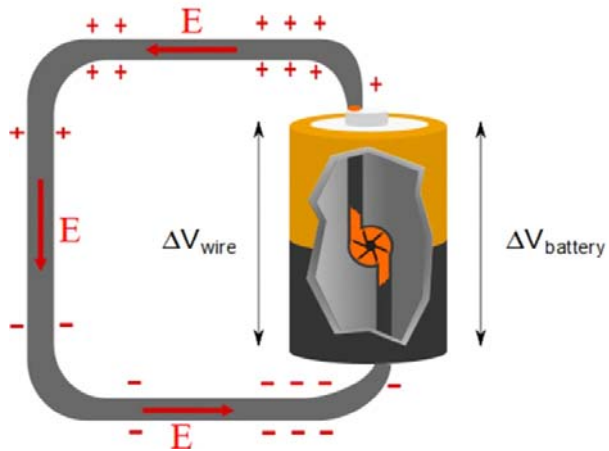

We must conclude that if we create an emf, we must have created an electric field.

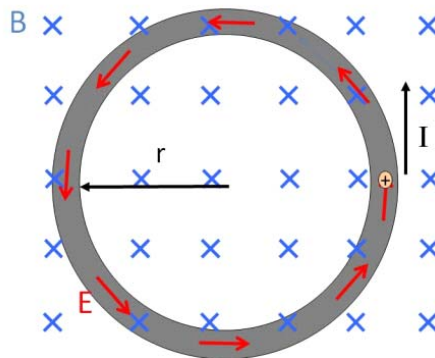

This is really interesting. We now have a hint at how wireless chargers might work (we

will return to this later). But now let's ask ourselves, do we need the wire there for this electric field to happen? Of course, the force on the charge is the same if there is no wire, so the  $E$ -field must be there whether or not there is a wire.

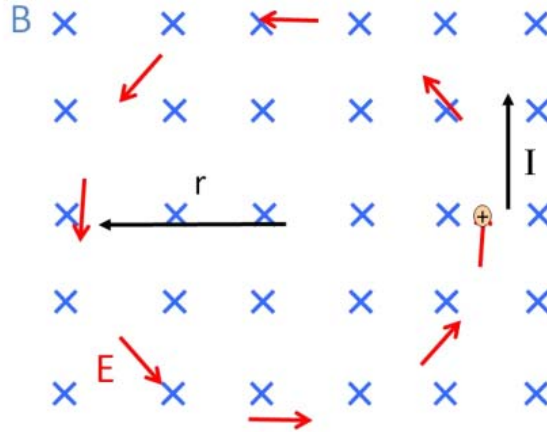

Question 223.45.6  
Question 223.45.7

In fact, the electric field is there in every place the magnetic field exists so long as the magnetic field continues to increase.

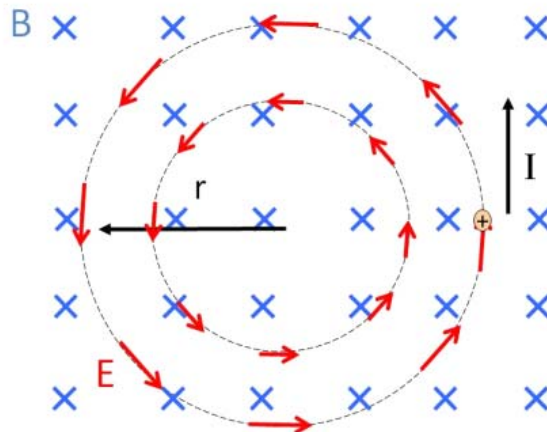

This is quite a profound statement. We have said that a changing magnetic field *creates* an electric field. Before, only charges could create electric fields, but in this case, the magnetic field is creating the electric field. Of course, we know that moving charges are making the magnetic field, so it is not totally surprising that the fields would be related.

This electric field is just like a field produced by charges in that it exerts a force

$$F = q_o E$$

on a charge  $q_o$ . But the electric field source is now very different.

## Relationship between induced fields

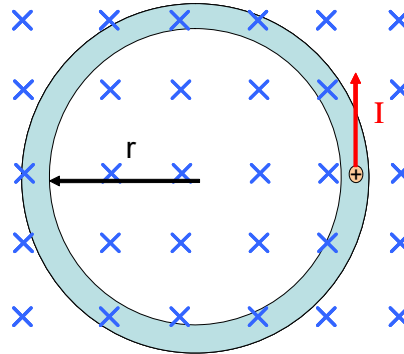

Question 223.45.8

It would be nice to have a relationship between the changing  $B$ -field and the  $E$ -field that is created. It would be good to obtain the most general relationship we can that relates the electric field to the magnetic field. By understanding this relationship, we can hope to gain insight into how to build things, and into how the universe works. Let's start with a thought experiment.

Suppose we have a uniform but time varying magnetic field into the paper. In this field, we have a conducting ring. If the field strength is increasing, then the charges in the conducting loop shown will feel an induced emf, and they will form a current that is tangent to the ring.

Let's find the work required to move a charge once around the loop. The amount of potential energy difference is equal to the work done, so

$$|\Delta U| = |W|$$

but in terms of the electric potential this is

$$\Delta U = q\Delta V = q\mathcal{E}$$

so

$$|W| = |q\mathcal{E}|$$

Now let's do this another way. Let's use

$$W = \int \mathbf{F} \cdot d\mathbf{s}$$

The force making the current move is due to the induced potential difference. This is just

$$F = qE$$



which will not change as we go around the loop. The path will be along the loop, so

$$W = \int_{loop} F ds$$

and since the  $E$ -field is uniform in space at any given time as we travel around the loop,

$$W = F \int_{loop} ds = qE2\pi r$$

So we have two expressions for the work. Let's set them equal to each other

$$q\mathcal{E} = qE2\pi r$$

The electric field is then

$$\frac{\mathcal{E}}{2\pi r} = E \quad (29.8)$$

but

$$\mathcal{E} = -N \frac{d\Phi_B}{dt}$$

so

$$\begin{aligned} E &= \frac{-N}{2\pi r} \frac{d\Phi_B}{dt} \\ &= \frac{-1}{2\pi r} \frac{d\Phi_B}{dt} \end{aligned}$$

So if we know how our  $B$ -field varies in time, we can find the  $E$ -field that the changing  $B$ -field induces. Let's rewrite this one more time

$$2\pi r E = - \frac{d\Phi_B}{dt}$$

Since the  $E$ -field is constant in as we go around the loop, we can recognize the LHS as

$$2\pi r E = \int \vec{\mathbf{E}} \cdot d\vec{\mathbf{s}}$$

which should be little surprise, since we found

$$\Delta V = \int \vec{\mathbf{E}} \cdot d\vec{\mathbf{s}}$$

to be our basic definition of the electric potential. So

$$\int \vec{\mathbf{E}} \cdot d\vec{\mathbf{s}} = - \frac{d\Phi_B}{dt} \quad (29.9)$$

This is a more general form of Faraday's law of induction.

This electric field is fundamentally different than the  $E$ -fields we studied before. It is not a static field. If it were, then  $\int \vec{\mathbf{E}} \cdot d\vec{\mathbf{s}}$  would be zero around a ring of current.

Think of Kirchoff's loop rule. Around a closed loop  $\Delta V = 0$  normally. Then

$$\Delta V = \int \vec{\mathbf{E}} \cdot d\vec{\mathbf{s}} = 0 \quad \text{no magnetic field}$$

But since  $\int \vec{\mathbf{E}} \cdot d\vec{\mathbf{s}} \neq 0$  for our induced  $E$ -field, we must recognize that this field is different from those made by static charges. We call this field that does not return the charge to the same energy state on traversing the loop a *nonconservative field*. It is still just an electric field, but we are gaining energy from the magnetic field, so  $\Delta V$  around

the loop is not zero.

The equation

$$\int \vec{E} \cdot d\vec{s} = -\frac{d\Phi_B}{dt} \quad (29.10)$$

is the most general form of Faraday's equation, but it is hard to use in calculation for normal circuits where there is no magnetic field or where the fields are weak. So we won't use it as we design normal circuits (we will use the idea of inductance instead, which we will soon study). But it plays a large part in the electromagnetic theory of optics (PH375). We will just get a taste of this here.

## Electromagnetic waves

Question 223.45.9

Let's return to the idea that a changing magnetic field makes an electric field.

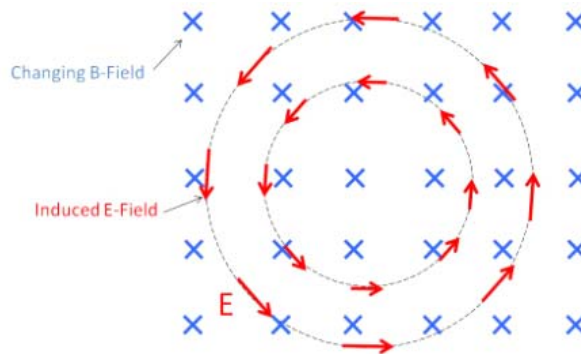

But what about a changing electric field?

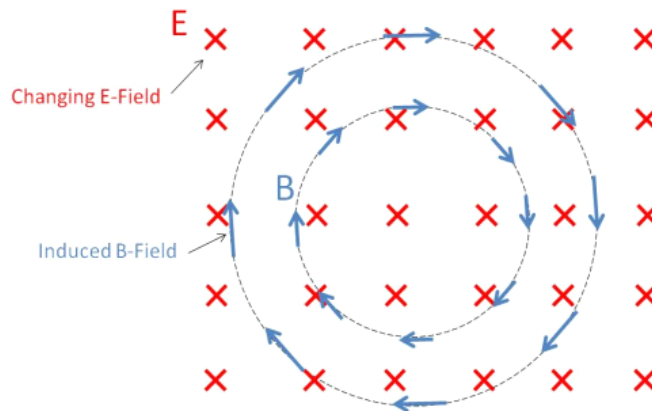

For the electric and magnetic field equations to be symmetric, the changing electric field must create a magnetic field. There is no requirement that the universe display

Question 223.45.10

such symmetry, but we have found that it usually does. Indeed, a changing electric field creates a magnetic field.

This foreshadows our final study of light. We learned earlier that light is an *electromagnetic* wave. What this means is that light is a wave in both the electric *and* magnetic fields.

Maxwell first predicted that such a wave could exist. The electric field of the wave changes in time like a sinusoid. But this change will produce a magnetic field that will also change in time. This changing magnetic field recreates the electric field—which recreates the magnetic field, etc. Thus the electromagnetic wave is *self-sustaining*. It can break off from the charges that create it and keep going forever because the electric field and magnetic field of the wave create each other. You often see the electromagnetic wave drawn like this:

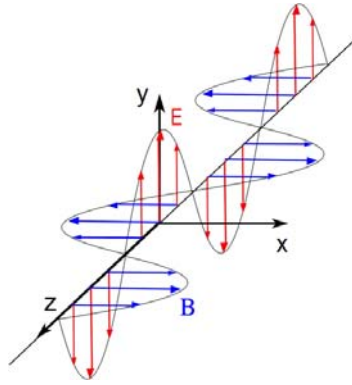

Where you can see the electric and magnetic fields being created and recreated to make the wave self sustaining.

This is a direct result of Maxwell's study of electromagnetic field theory. Our more complete version of Faraday's law is one of the fundamental equations describing electromagnetic waves known as *Maxwell's Equations*.

$$\int \vec{E} \cdot d\vec{s} = -\frac{d\Phi_B}{dt}$$

You might guess that the symmetry we have observed would give another similar equation relating the magnetic field and the electric flux.

$$\int \vec{B} \cdot d\vec{s} = +\frac{d\Phi_E}{dt}$$

and we will find that this is true! But we have yet to show that is so. Note that  $\int \vec{B} \cdot d\vec{s}$  shows up in Ampere's law,

$$\int \vec{B} \cdot d\vec{s} = \mu_o I$$

so this last equation is not complete, but we are guessing that there is also the possibility of an induced magnetic field from a changing electric field, so we can predict that we need to modify Ampere's law to be

$$\int \vec{\mathbf{B}} \cdot d\vec{\mathbf{s}} = \mu_o I + \frac{d\Phi_E}{dt}$$

but again we will have to show this later.

In the next lecture, we will take a break from this deep theoretical discussion, and learn how to use induction to make useful circuit devices.

## Basic Equations

# 30 Inductors

## Fundamental Concepts

- The self inductance  $L$  has all the geometric and material properties of a coil or other inductor and it can be found using  $L = N \frac{d\Phi_B}{dI}$
- The emf induced by an inductor is given by  $\mathcal{E} \equiv -L \frac{\Delta I}{\Delta t}$
- For a solenoid, the inductance can be found to be  $L = \mu_o n^2 V$
- The energy stored in the magnetic field is  $U_L = \frac{1}{2} L I^2$  and the energy density in the magnetic field is  $u_B = \frac{1}{2} \frac{1}{\mu_o} B^2$
- There is an *apparent* voltage drop across an inductor of  $\Delta V_{L_{apparent}} = -L \frac{dI}{dt}$
- There is also a mutual inductance between two inductors given by  $M_{12} = \frac{N_2 \Phi_{12}}{I_1}$

## Self Inductance

Question 223.46.1

When we put capacitors and resistors in a circuit, we found that the current did not jump to its ultimate current value all at once. There was a time dependence. But really, even if we just have a resistor (and we always have some resistance) the current does not reach its full value instantaneously. Think of our circuits, they are current loops! So as the current starts to flow, Lenz's law tells us that there will be an induced emf that will oppose the flow. The potential drop across the resistor in a simple battery-resistor circuit is the potential drop due to the battery emf, *minus the induced emf*.

We can use this fact to control current in circuits. To see how, we can study a new case

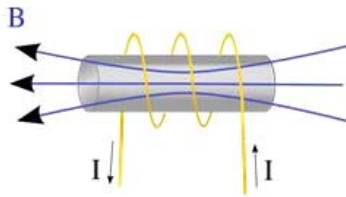

Let's take a coil of wire wound around an iron cylindrical core. We start with a current as shown in the figure above. Using our right hand rule we can find the direction of the

$B$ -field. But we now will allow the current to change. As it gets larger, we know

$$\mathcal{E} = -N \frac{d\Phi_B}{dt}$$

and we know that as the current changes, the magnitude of the  $B$ -field will change, so the flux through the coil will change. We will have an induced emf. We could derive this expression, but I think you can see that the induced emf is proportional to the *rate of change* of the current.

$$\mathcal{E} \equiv -L \frac{\Delta I}{\Delta t}$$

You might ask if the number of loops in the coil matters. The answer is—yes. Does the size and shape of the coil matter—yes. But we will include all these geometrical effects in the constant  $L$  called the *inductance*. It will hold all the material properties of the iron cored coil.

$$\mathcal{E} = -N \frac{d\Phi_B}{dt} \equiv -L \frac{dI}{dt}$$

so for this case

$$-N \frac{d\Phi_B}{dt} \frac{dt}{dI} \equiv -L$$

or

$$L = N \frac{d\Phi_B}{dI}$$

If we start with no current (so no flux), then our change in flux is the current flux minus zero. We can then say that

$$L = N \frac{\Phi_B}{I}$$

It might be more useful to write the inductance as

$$L = - \frac{\mathcal{E}_L}{\frac{dI}{dt}}$$

In designing circuits, we will usually just look up the inductance of the device we choose, like we looked up the resistance of resistors or the capacitance of the capacitors we use.

But for our special case of a simple coil, we can calculate the inductance, because we know the induced emf using Faraday's law

### Inductance of a solenoid<sup>19</sup>

Question 223.46.2

Let's extend our calculation for our coil. Really the only easy case we can do is that of a

<sup>19</sup> Think of this like the special case of a capacitor made from two flat large plates, the parallel plate capacitor. It was somewhat ideal in the way we treated it. Our treatment of the special case of a coil will likewise be somewhat ideal.

solenoid (that's probably a hint for the test). So let's do it! We will just fill our solenoid with air instead of iron (if we have iron, we have to take into account the magnetization, so it is not terribly hard, but this is not what we want to concentrate on now). If the solenoid has  $N$  turns with length  $L$  and we assume that  $L$  is much bigger than the radius  $r$  of the loops then we can use our solution for the  $B$ -field created by a solenoid

$$\begin{aligned} B &= \mu_o n I \\ &= \mu_o \frac{N}{\ell} I \end{aligned}$$

The flux through each turn is then

$$\Phi_B = BA = \mu_o \frac{N}{\ell} IA$$

where  $A$  is the area of one of the solenoid loops. Then we use our equation for inductance for a coil

$$\begin{aligned} L &= N \frac{\Phi_B}{I} \\ &= N \frac{(\mu_o \frac{N}{\ell} IA)}{I} \\ &= \frac{(\mu_o N^2 A)}{\ell} \\ &= \frac{(\mu_o N^2 A)}{\ell} \frac{\ell}{\ell} \\ &= \frac{\mu_o N^2 A \ell}{\ell^2} \\ &= \frac{\mu_o N^2 V}{\ell^2} \\ &= \mu_o n^2 V \end{aligned}$$

where we used the fact that the volume of the solenoid is  $V = A\ell$ .

Many inductors built for use in electronics are just this, air filled solenoids. So this really is a somewhat practical solution.

## Energy in a Magnetic Field

Question 223.46.3

An inductor, like a capacitor, stores energy in its field. We would like to know how much energy an inductor can store. From basic circuit theory we know the power in a circuit will be

$$\mathcal{P} = I\Delta V$$

If we just have an inductor, then the power removed from the circuit is

$$\begin{aligned}\mathcal{P}_{cir} &= I\Delta V = I\mathcal{E} \\ &= I\left(-L\frac{dI}{dt}\right) \\ &= -LI\frac{dI}{dt}\end{aligned}$$

As with a resistor, we are taking power *from the circuit* so the result is negative. But unlike a resistor, this power is not being dissipated as heat. It is going into the magnetic field of the inductor. Therefore, we expect the power stored in the inductor field to be

$$\mathcal{P}_L = -\mathcal{P}_{cir} = LI\frac{dI}{dt}$$

Power is the time rate of change of energy, so we can write this power delivered to the inductor as

$$\frac{dU_L}{dt} = LI\frac{dI}{dt}$$

Multiplying by  $dt$  gives

$$dU_L = LI dI$$

To find the total energy stored in the inductor we must integrate over  $I$ .

$$\begin{aligned}U_L &= \int dU_L \\ &= \int_0^I LI dI \\ &= L \int_0^I I dI \\ &= \frac{1}{2}LI^2\end{aligned}$$

Thus,

$$U_L = \frac{1}{2}LI^2$$

is the energy stored in the magnetic field of the inductor.

Suppose we have an inductor  $L = 30.0 \times 10^{-3}$  H. Plotting shows us the dependence of  $U_L$  on  $I$ .



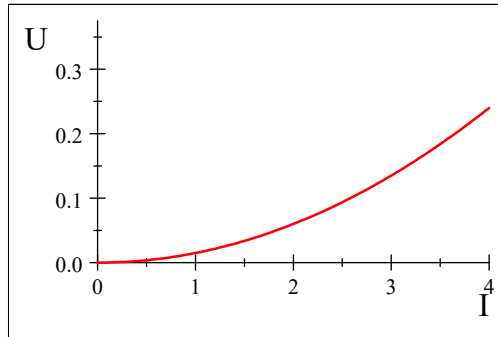

We should take a moment to see how our inductor compares to a capacitor as an energy storage device. The energy stored in the electric field of a capacitor

$$U_L = \frac{1}{2}L(I)^2$$

$$U_C = \frac{1}{2}C(\Delta V)^2$$

Notice that Remarkable similarity!

## Energy Density in the magnetic field

Question 223.46.4

We found that there was energy stored in the electric field of a capacitor. Is the energy stored in the inductor really stored in the magnetic field of the inductor? We believe that this is just the case, the energy,  $U_L$ , is stored in the field. We would like to have an expression for the density of the energy in the field.

To see this, let's start with the inductance of a solenoid.

$$L = \mu_0 n^2 A \ell$$

The magnetic field is given by

$$B = \mu_0 n I$$

then the energy in the field is given by

$$U_B = \frac{1}{2}LI^2$$

$$= \frac{1}{2}\mu_0 n^2 A \ell I^2$$

If we rearrange this, we can see the solenoid field is found in the expression twice

$$\begin{aligned} U_B &= \frac{1}{2} (\mu_o n I) A \ell \frac{\mu_o n I}{\mu_o} \\ &= \frac{1}{2\mu_o} B^2 A \ell \end{aligned}$$

and the energy density is

$$\begin{aligned} u_B &= \frac{U_B}{A \ell} \\ &= \frac{1}{2} \frac{1}{\mu_o} B^2 \end{aligned}$$

Just like our energy density for the electric field, we derived this for a specific case, a solenoid. But this expression is general. We should compare to the energy density in the electric field.

$$u_E = \frac{1}{2} \epsilon_o E^2$$

Again, note the similarity!

## Oscillations in an LC Circuit

We introduce a new circuit symbol for inductors



It looks like a coil, for obvious reasons. We can place this new circuit element in a circuit. But what will it do? To investigate this, let's start with a simple case, a circuit with a charged capacitor and an inductor and nothing else.

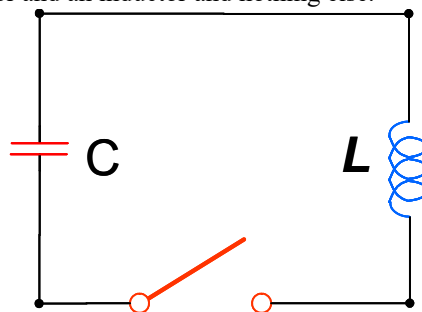

Let us make two unrealistic assumptions (we will relax these assumptions later).

Assumption 1: There is no resistance in our LC circuit.

Assumption 2: There is no radiation emitted from the circuit.

Given these two assumptions, there is no mechanism for energy to escape the circuit.

Question 223.46.5

Energy must be conserved. Can we describe the charge on the capacitor, the current, and the energy as a function of time?

It may pay off to recall some details of oscillators. Energy of the Simple Harmonic Oscillator

Remember from Dynamics or PH121 that a mass-spring system will oscillate. The mass has kinetic energy because the mass is moving

$$K = \frac{1}{2}mv^2 \quad (30.1)$$

for our Simple Harmonic Oscillator we know that the position of the mass as a function of time is given by

$$x(t) = x_{\max} \cos(\omega t + \phi)$$

and the speed as a function of time is

$$v(t) = -\omega x_{\max} \sin(\omega t + \phi)$$

then the kinetic energy as a function of time is

$$\begin{aligned} K &= \frac{1}{2}m(-\omega x_{\max} \sin(\omega t + \phi))^2 \\ &= \frac{1}{2}m\omega^2 x_{\max}^2 \sin^2(\omega t + \phi) \\ &= \frac{1}{2}m \frac{k}{m} x_{\max}^2 \sin^2(\omega t + \phi) \\ &= \frac{1}{2}kx_{\max}^2 \sin^2(\omega t + \phi) \end{aligned}$$

The spring has potential energy given by

$$U = \frac{1}{2}kx^2 \quad (30.2)$$

For our mechanical oscillator the potential as a function of time is

$$U = \frac{1}{2}kx_{\max}^2 \cos^2(\omega t + \phi)$$

The total energy is given by

$$\begin{aligned} E &= K + U \\ &= \frac{1}{2}kx_{\max}^2 \sin^2(\omega t + \phi) + \frac{1}{2}kx_{\max}^2 \cos^2(\omega t + \phi) \\ &= \frac{1}{2}kx_{\max}^2 (\sin^2(\omega t + \phi) + \cos^2(\omega t + \phi)) \\ &= \frac{1}{2}kx_{\max}^2 \end{aligned}$$

If we plot the kinetic and potential energies it looks like this

We can see that the total energy won't change, and the energy switches back and forth from kinetic to potential as the mass moves back and forth. If we plot the kinetic and potential energy at points along the mass' path we get something like this.

Question 223.46.6

One of the important uses of an inductor is to create *electrical oscillations*. Having recalled what oscillations look like, we can see that a LC circuit will have an oscillating current.

here is our circuit again.

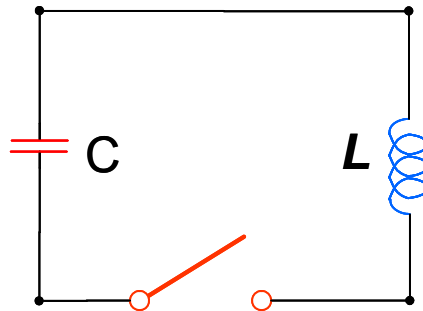

We will start with the switch open the capacitor charged to its maximum value  $Q_{\max}$ . For  $t > 0$  the switch is closed. Recall that the energy stored in the capacitor is

$$U_C = \frac{Q^2}{2C}$$

and the energy stored in the inductor is

$$U_L = \frac{1}{2}I^2L$$

The total energy (because of our assumptions) is

$$\begin{aligned} U &= U_C + U_L \\ &= \frac{Q^2}{2C} + \frac{1}{2}I^2L \end{aligned}$$

The change in energy over time must be zero (again because of our assumptions) so

$$\begin{aligned} \frac{dU}{dt} &= 0 \\ &= \frac{d}{dt} \left( \frac{Q^2}{2C} + \frac{1}{2}I^2L \right) \\ &= \frac{Q}{C} \frac{dQ}{dt} + LI \frac{dI}{dt} \end{aligned}$$

We recall that

$$I = \frac{dQ}{dt}$$

$$0 = \frac{Q}{C} \left( \frac{dQ}{dt} \right) + LI \frac{dI}{dt}$$

$$0 = \frac{Q}{C} (I) + LI \frac{dI}{dt}$$

$$0 = \frac{Q}{C} I + LI \frac{d \left( \frac{dQ}{dt} \right)}{dt}$$

$$0 = \frac{Q}{C} + L \frac{d^2Q}{dt^2}$$

or

$$\frac{d^2Q}{dt^2} = -\frac{Q}{LC}$$

This is a differential equation that we recognize from M316. It looks just like the differential equation for oscillatory motion! We try a solution of the form

$$Q = A \cos(\omega t + \phi)$$

then

$$\frac{dQ}{dt} = -A\omega \sin(\omega t + \phi)$$

and

$$\frac{d^2Q}{dt^2} = -A\omega^2 \cos(\omega t + \phi)$$

thus

$$A\omega^2 \cos(\omega t + \phi) = -\frac{1}{LC} A \cos(\omega t + \phi)$$

This is indeed a solution if

$$\omega = \frac{1}{\sqrt{LC}}$$

When  $\cos(\omega t + \phi) = 1$ ,  $Q = Q_{\max}$ , thus

$$Q = Q_{\max} \cos(\omega t + \phi)$$

Now recall,

$$\begin{aligned} I &= \frac{dQ}{dt} \\ &= \frac{d}{dt} (Q_{\max} \cos(\omega t + \phi)) \\ &= -\omega Q_{\max} \sin(\omega t + \phi) \end{aligned}$$

We would like to determine  $\phi$ . We use the initial conditions  $t = 0$ ,  $I = 0$  and  $Q = Q_{\max}$ . Then

$$0 = -\omega Q_{\max} \sin(\phi)$$

This is true for  $\phi = 0$ . Then

$$\begin{aligned} Q &= Q_{\max} \cos(\omega t) \\ I &= -\omega Q_{\max} \sin(\omega t) \\ &= -I_{\max} \sin(\omega t) \end{aligned}$$

We can use the solution for the charge on the capacitor and the current in the inductor as a function of time to expand our energy equation

$$\begin{aligned} U &= U_C + U_L \\ &= \frac{Q^2}{2C} + \frac{1}{2} I^2 L \\ &= \frac{1}{2C} Q_{\max}^2 \cos^2(\omega t) + \frac{1}{2} L I_{\max}^2 \sin^2(\omega t) \end{aligned}$$

This looks a lot like our kinetic and potential energy equation for a mass-spring system. The energy shifts from the capacitor to the inductor and back like energy shifted from kinetic to potential energy for our mass-spring, with the components out of phase by  $90^\circ$ . By energy conservation, we know that

$$\frac{1}{2C} Q_{\max}^2 = \frac{1}{2} L I_{\max}^2$$

that is, the maximum energy in the capacitor equals the maximum energy in the inductor. Then the total energy

$$\begin{aligned} U &= \frac{1}{2C} Q_{\max}^2 \cos^2(\omega t) + \frac{1}{2} L I_{\max}^2 \sin^2(\omega t) \\ &= \frac{1}{2C} Q_{\max}^2 \cos^2(\omega t) + \frac{1}{2C} Q_{\max}^2 \sin^2(\omega t) \\ &= \frac{Q_{\max}^2}{2C} \end{aligned}$$

which must be the case if energy is conserved. We can plot the capacitor and inductor energies at points in time as the current switches back and forth.

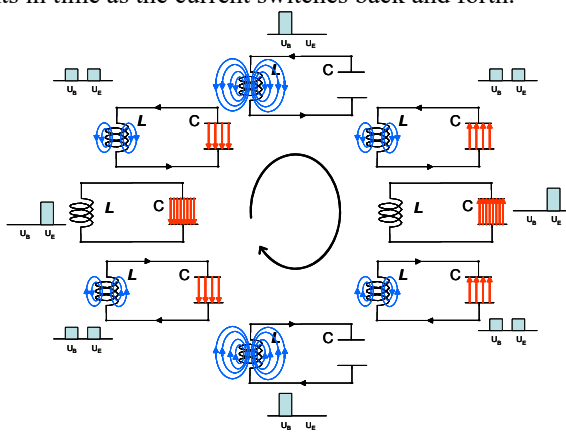

This is very much like our harmonic oscillator picture. We can see that we have, indeed made an electronic oscillator.

This type of circuit is a major component of radios which need a local oscillatory circuit to operate.

### The RLC circuit

As fascinating as the last section was, we know there really is some resistance in the wire. So the restriction of no resistance needs to be relaxed in our analysis.

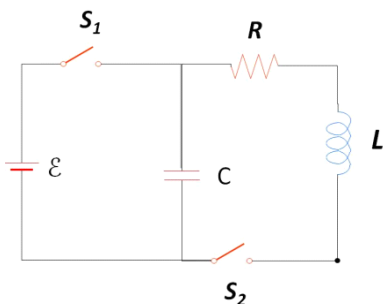

We can use the circuit in the picture to imagine an LRC circuit. At first, we will keep  $S_2$  open and close  $S_1$  to charge up the capacitor. Then we will close  $S_1$  and open  $S_2$ . What will happen?

It is easier to find the current and charge on the capacitor as a function of time by using



energy arguments. The resistor will remove energy from the circuit by dissipation (getting hot). The circuit has energy

$$U = \frac{Q^2}{2C} + \frac{1}{2}LI^2 \quad (30.3)$$

so from the work energy theorem,

$$W_{nc} = \Delta U$$

the energy lost will be related to a change in the energy in the capacitor and the inductor. Let's look at the rate of energy loss again

$$\begin{aligned} \frac{dU}{dt} &= \frac{d}{dt} \left( \frac{Q^2}{2C} + \frac{1}{2}LI^2 \right) \\ &= \frac{Q}{C} \frac{dQ}{dt} + LI \frac{dI}{dt} \end{aligned} \quad (30.4)$$

but this must be equal to the loss rate. The power lost will be  $P = I^2 R$

$$-I^2 R = \frac{Q}{C} \frac{dQ}{dt} + LI \frac{dI}{dt} \quad (30.5)$$

This is a differential equation we can solve, let's first rearrange, remembering that

$$I = \frac{dQ}{dt}$$

then

$$\begin{aligned} -I^2 R &= \frac{Q}{C} I + LI \frac{dI}{dt} \\ -IR &= \frac{Q}{C} + L \frac{dI}{dt} \end{aligned}$$

again using  $I = \frac{dQ}{dt}$

$$+L \frac{d^2 Q}{dt^2} + \frac{dQ}{dt} R + \frac{Q}{C} = 0 \quad (30.6)$$

This is a good exercise for those of you who have taken math 316. This is just like the equation governing a damped harmonic oscillator. The solution is

$$Q = Q_{\max} e^{-\frac{Rt}{2L}} \cos \omega_d t \quad (30.7)$$

where the angular frequency,  $\omega_d$  is given by

$$\omega_d = \left( \frac{1}{LC} - \left( \frac{R}{2L} \right)^2 \right)^{\frac{1}{2}} \quad (30.8)$$

Remember that for a damped harmonic oscillator

$$x(t) = Ae^{-\frac{b}{2m}t} \cos(\omega t + \phi)$$

and

$$\omega = \left( \frac{k}{m} - \left( \frac{b}{2m} \right)^2 \right)^{\frac{1}{2}}$$

The resistance acts like a damping coefficient! Suppose

$$\begin{aligned}
 Q_{\max} &= 0.05 \text{ C} \\
 R &= 5 \Omega \\
 L &= 50 \text{ H} \\
 C &= 0.02 \text{ F}
 \end{aligned}$$

we have a graph that looks like this.

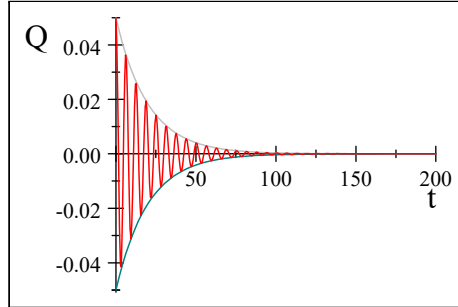

The gray lines are

$$\pm Q_{\max} e^{-\frac{Rt}{2L}} \quad (30.9)$$

They describe how the amplitude changes. We call this the *envelope* of the curve.

Let's look at

$$\omega_d = \left( \frac{1}{LC} - \left( \frac{R}{2L} \right)^2 \right)^{\frac{1}{2}} \quad (30.10)$$

If  $\omega_d = 0$  then

$$\begin{aligned}
 0 &= \frac{1}{LC} - \left( \frac{R}{2L} \right)^2 \\
 \frac{1}{LC} &= \left( \frac{R}{2L} \right)^2 \\
 2L \sqrt{\frac{1}{LC}} &= R
 \end{aligned}$$

or

$$R = \sqrt{\frac{4L}{C}} \quad (30.11)$$

We know that if  $\omega_d = 0$  there is no oscillation. We will call this the critical resistance,  $R_c$ . When the resistance is  $R \geq R_c$  there will be no oscillation. These represent the cases of being critically damped ( $R = R_c$ ) and overdamped ( $R > R_c$ ). If  $R < R_c$  we are underdamped, and the circuit will oscillate.

We don't know how to make electromagnetic waves yet, but we will in a few lectures. Those waves carry what we call radio signals. To make the waves, we often use circuits with resistors, capacitors, and inductors to provide the oscillation. You can guess that if  $Q$  on the capacitor oscillates, so does the current. This oscillating current is what we

use to drive the radio antenna.

Now that we have some resistance, we could consider a circuit with just an inductor and a resistor and a battery.

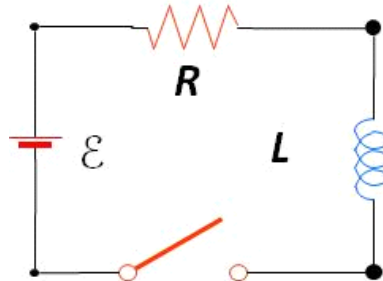

This is a little harder than our author indicates. We will examine the difficulties in thinking about such a circuit in the next section.

### Return to Non-Conservative Fields

A few decades ago, we could have stopped here in an engineering class in considering and LRC circuit. But as electrical devices become every more complicated, it might be good if we examine circuits with inductors and resistors more carefully. A few lectures ago we found that

$$\int \mathbf{E} \cdot d\mathbf{s} = -\frac{d\Phi_B}{dt}$$

implies a non-conservative electric field. We should take a moment to see what this means. We should also, if we have time, investigate mutual inductance, which has become a major engineering technique for wireless power. First let's consider the following circuit.[?]

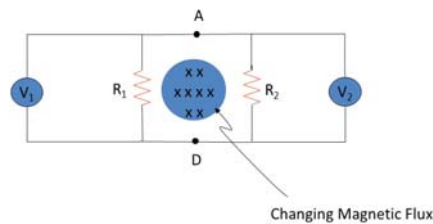

notice that there is no battery. If the field flux changes, will there be a potential difference measured by the voltmeters? Let's use Kirchhoff's rules to analyze the circuit. I can draw in guesses for the currents.

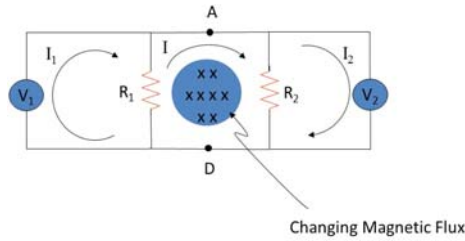

and now we use the junction and loop rules to find the voltages.

But recall that

$$\oint \mathbf{E} \cdot d\mathbf{s} = 0$$

was the basis for Kirchhoff's loop rule. And we learned that this is not true for induced emfs. So in the middle loop Kirchhoff's loop rule is not true! We now know that because of the changing magnetic field,

$$\oint \mathbf{E} \cdot d\mathbf{s} = \mathcal{E} = -\frac{d\Phi_B}{dt}$$

for this middle loop. Now then,  $\mathcal{E}$  comes just from the changing external flux. It does *not* depend on  $R_1$  or on  $R_2$ .

We can write a Kirchhoff's law-like equation for each loop.

$$I_1 R_i - I R_1 = 0$$

$$-I R_1 - I R_2 + \mathcal{E} = 0$$

$$I_2 R_i - I R_2 = 0$$

where  $R_i$  is the internal resistance of the voltmeters. If there were no  $\mathcal{E}$ , then the volt meters would certainly not read anything, but now we see that

$$|V_1| = I_1 R_i \approx I R_1$$

$$|V_2| = I_2 R_i \approx I R_2$$

This seems crazy. Each volt meter reads a different voltage.

To understand this, remember that our induced field is not a conservative field. As we go around the loop we no longer expect to get back to our starting voltage. We have lost some energy in making a magnetic field. And for non-conservative fields,  $\oint \mathbf{E} \cdot d\mathbf{s}$  is *path dependent*.

So as crazy as it seems, this is actually what we would find, each volt meter reads a different voltage.

To try to make this idea of inductance make some sense, let's take another strange

circuit.

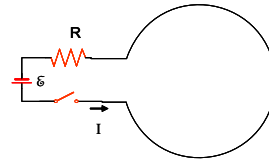

There is a battery, and resistor, and a single loop inductor. When the switch is thrown, the current will flow as shown. The current will create a magnetic field that is out of the page in the center of the loop. Since the loop, itself, is creating this field, let's call this field a *self-field*.

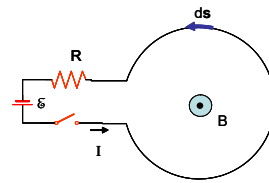

Consider this self-field for a moment. When we studied charge, we found that charge created an electric field. That electric field could make *another* charge accelerate. But the electric field created by a charge does not make the charge that created it accelerate. This is an instance of a self-field, an electric self-field. Now with this background, let's return to our magnetic self-field.

Let's take Faraday's law and apply it to this circuit. Let me choose an area vector  $\mathbf{A}$  that is the area of the big loop and positive out of the page. Again, let's use Kirchoff's loop law. Let's find  $\oint \mathbf{E} \cdot d\mathbf{s}$  for the entire circuit. We can start with the battery. Since there is an electric field inside the battery we will have a component of  $\oint \mathbf{E} \cdot d\mathbf{s}$  as we cross it. The battery field goes from positive to negative. If we go counter-clockwise, our  $d\mathbf{s}$  direction traverses this from negative to positive, so the electric field is up and the  $d\mathbf{s}$  direction is down, we have

$$\oint_{bat} \mathbf{E} \cdot d\mathbf{s} = -\mathcal{E}_{bat}$$

for this section of the circuit. Suppose we have ideal wires. If the wire has no resistance, then it takes no work to move the charges through the wire. In this case, an electron launched by the electric in the battery just coasts from the battery to the resistor. There is no need to have an acceleration in the ideal wire. The electric potential won't change from the battery to the resistor. So there won't be a field in this ideal wire part. But let's next we consider the resistor. There is a potential change as we go across it. And if there is a change in potential, there must be an electric field. So the resistor also has an electric field inside of it. We have a component of  $\oint \mathbf{E} \cdot d\mathbf{s}$  that is equal to  $\mathcal{E}_R = IR$

from this field.

$$\oint_R \mathbf{E} \cdot d\mathbf{s} = IR$$

Now we come to the big loop part. Since we have ideal wire, there is no resistance in this part so there is no voltage drop for this part of the circuit. All the energy that was given to the electrons by the battery was lost in the resistor. They just coast back to the other terminal of the battery. Since there is no voltage drop in the big loop,

$$\mathcal{E}_{\text{big loop}} = 0$$

there is no electric field in the big loop either. Along the big loop,  $d\mathbf{s}$  is certainly not zero. so

$$\mathcal{E}_{\text{big loop}} = \oint_{\text{big loop}} \mathbf{E} \cdot d\mathbf{s} = 0$$

For the total loop we would have

$$\oint \mathbf{E} \cdot d\mathbf{s} = -\mathcal{E}_{\text{batt}} + IR + 0 \quad (30.12)$$

Normally, Kirchhoff's loop rule would say that all this must be zero, since the sum of the energy changes around the loop must be zero if no energy is lost. But now we know energy *is* lost in making a magnetic field.

Consider the magnetic flux through the circuit. The magnetic field is made by the current in the circuit. Note that we arranged the circuit so the battery and resistor are in a part that has very little area, so we can ignore the flux through that part of the circuit. Most of the flux will go through the big loop part. The magnetic field is out of the paper inside of the loop. The flux is

$$\Phi_B = \oint \mathbf{B} \cdot d\mathbf{A} \quad (30.13)$$

and  $\mathbf{B}$  and  $\mathbf{A}$  are in the same direction.  $\Phi_B$  is positive.

Then from Biot-Savart

$$\mathbf{B} = \frac{\mu_o I}{4\pi} \oint \frac{d\mathbf{s} \times \hat{\mathbf{r}}}{r^2} \quad (30.14)$$

Let me write this as

$$\begin{aligned} \mathbf{B} &= I \left( \frac{\mu_o}{4\pi} \oint \frac{d\mathbf{s} \times \hat{\mathbf{r}}}{r^2} \right) \\ &= I (\text{geometry factor}) \end{aligned} \quad (30.15)$$

If the geometry of the situation does not change, then  $B$  and  $I$  are proportional. Since  $B \propto I$ , then  $\Phi_B \propto I$  since the integral in Biot-Savart is the surface integral of  $\mathbf{B}$ , and  $\mathbf{B}$  is everywhere proportional to  $I$ . Instead of using Biot-Savart, I wish to just define a constant of proportionality that will contain all the geometric factors. I will simply say that

$$\Phi_B = LI \quad (30.16)$$

where  $L$  is my geometry factor. This geometry factor is just our inductance! This is what inductance is. It is all the geometry factors that make up our loop that will make the magnetic field if we put a current through it.

Assuming I don't change the geometry, then the inductance won't change and we have

$$\frac{d\Phi_B}{dt} = L \frac{dI}{dt} \quad (30.17)$$

and Faraday's law gives us

$$\mathcal{E} = -\frac{d\Phi_B}{dt} = -L \frac{dI}{dt} \quad (30.18)$$

Which says that we should not have expected  $\oint \mathbf{E} \cdot d\mathbf{s} = 0$  for our case as we traverse the entire circuit. Integrating  $\oint \mathbf{E} \cdot d\mathbf{s}$  around the whole circuit including the big loop should not bring us back to zero voltage. We have lost energy in making the field. Instead it gives

$$\oint \mathbf{E} \cdot d\mathbf{s} = -L \frac{dI}{dt}$$

We are dealing with non-conservative fields. So we have some energy loss like we would with a frictional force. It took some energy to make the magnetic field!

With this insight, we can now make a Kirchhoff-like loop like rule for such a situation. Integrating around the whole circuit gives

$$\oint \mathbf{E} \cdot d\mathbf{s} = -\mathcal{E}_{bat} + \mathcal{E}_R$$

Which we now realize should give  $-L \frac{dI}{dt}$  so

$$\oint \mathbf{E} \cdot d\mathbf{s} = -\mathcal{E}_{bat} + \mathcal{E}_R = -L \frac{dI}{dt}$$

or more succinctly

$$-\mathcal{E}_{batt} + IR = -L \frac{dI}{dt}$$

Now I can take the RHS to the left and find

$$\mathcal{E}_{batt} - IR - L \frac{dI}{dt} = 0 \quad (30.19)$$

which certainly *looks* like Kirchhoff's rule with  $-L \frac{dI}{dt}$  being a voltage drop across the single loop inductor. Under most conditions we can just treat  $-L \frac{dI}{dt}$  as a voltage drop and it works fine. Most of the time thinking this way does not cause much of a problem. But technically it is not right!

We should consider where our magnetic flux came from. The magnetic flux was created by the current. It is a self-field. The current can't make a magnetic flux that would then modify that current. This self-flux won't make an electric field So there is no electric field in the big loop, so there is no potential drop in that part of the circuit. It is just

that  $\oint \mathbf{E} \cdot d\mathbf{s} \neq 0$  because our field is not conservative. We had to take some energy to create the magnetic field.

Now, if you are doing simple circuit design, you can pretend you don't know about Faraday's law and this complication and just treat  $-L \frac{dI}{dt}$  as though it were a voltage drop. But really it is just that going around the loop we should expect

$$\oint \mathbf{E} \cdot d\mathbf{s} = -L \frac{dI}{dt}$$

not

$$\oint \mathbf{E} \cdot d\mathbf{s} = 0$$

The danger is that if you are designing a complicated device that depends on there being an electric field in the inductor, your device will not work. We have *no external magnetic field*, our only magnetic field is the *self-field* which will not produce an electric field (or at least will form a very small electric field compared to the electric fields in the resistor and the battery, due to the small resistance in the real wire we use to make the big loop).

This is very subtle, and I struggle to remember this! Fortunately in most circuit design it does not matter. We just treat the inductor as though it were a true voltage drop.

I can make it even more exasperating by asking what you will see if you place a voltmeter across the inductor. What I measure is a "voltage drop" of  $LdI/dt$ , so maybe there is a voltage drop after all! But no, that is not right. The problem is that in introducing the voltmeter, we have created a new loop. For this loop, the field from our big loop *is* an external field. .

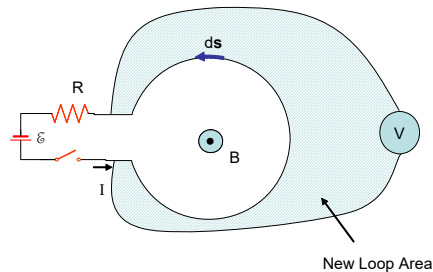

So the changing magnetic field through this voltmeter loop will produce an emf that will just match  $LdI/dt$ . And there will be an electric field—but it will be in the internal resistor in the voltmeter. And that is what you will measure!

Pick it up here

The bottom line is that for non-conservative fields you need to be careful. If you are just



designing simple circuits, you can just treat  $LdI/dt$  as though it were a voltage drop, but you may be badly burned by this if your system is more complicated, depending on the existence of a real electric field. You can see that if you are designing complicated sensing devices, you may need to deeply understand the underlying physics to get them to work.

## RL Circuits: Solving for the current as a function of time

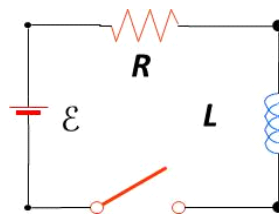

The equation we found from Faraday's law or incorrectly from Kirchoff's rule is

$$\mathcal{E} - IR - L\frac{dI}{dt} = 0 \quad (30.20)$$

This is a differential equation. We can solve it for the current. To do so, let's define a variable

$$x = \frac{\mathcal{E}}{R} - I$$

and then we see that

$$dx = -dI$$

Then we can write our differential equation as

$$\begin{aligned} \frac{\mathcal{E}}{R} - I - \frac{L}{R} \frac{dI}{dt} &= 0 \\ x + \frac{L}{R} \frac{dx}{dt} &= 0 \end{aligned}$$

and so

$$x = -\frac{L}{R} \frac{dx}{dt}$$

You might be able to guess the solution at this point from your M316 experience. But let's work it out as a review. We see that our  $x$  equation separates into

$$\frac{dx}{x} = -\frac{R}{L} dt$$

Integration yields

$$\int_{x_0}^x \frac{dx}{x} = -\int_0^t \frac{R}{L} dt$$

$$\ln\left(\frac{x}{x_o}\right) = -\frac{R}{L}t$$

exponentiating both sides gives

$$\left(\frac{x}{x_o}\right) = e^{-\frac{R}{L}t}$$

Now we replace  $x$  with  $\frac{\mathcal{E}}{R} - I$

$$\left(\frac{\frac{\mathcal{E}}{R} - I}{\frac{\mathcal{E}}{R} - I_o}\right) = e^{-\frac{R}{L}t}$$

And because at  $t = 0, I = 0$

$$\left(\frac{\frac{\mathcal{E}}{R} - I}{\frac{\mathcal{E}}{R}}\right) = e^{-\frac{R}{L}t}$$

rearranging gives

$$I = \frac{\mathcal{E}}{R} \left(1 - e^{-\frac{Rt}{L}}\right) \tag{30.21}$$

or, defining another time constant

$$\tau = \frac{L}{R} \tag{30.22}$$

we have

$$I = \frac{\mathcal{E}}{R} \left(1 - e^{-\frac{t}{\tau}}\right) \tag{30.23}$$

We can see that

$$\frac{\mathcal{E}}{R} = I_{\max} \tag{30.24}$$

comes from Ohm's law. So just like with our capacitor-resistor circuit, we have a current that grows in time, approaching the maximum value we get after a time  $t$  which is much longer than  $\tau$ .

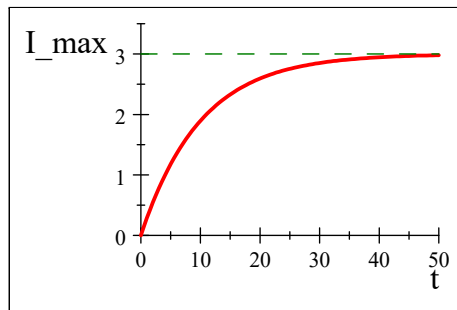

You might expect that, like for a capacitor, there is an equation for an inductor who has a maximum current flowing but for which the current source is shorted (disconnected,

and replaced with a resistanceless wire). The equation is

$$I = I_0 e^{-\frac{t}{\tau}} \quad (30.25)$$

## Magnetic Field Energy in Circuits

We found last lecture that just like with a  $RC$  circuit, we should expect there to be energy stored in a  $RL$  circuit.

$$U_L = \frac{1}{2}LI^2 = \frac{1}{2}C(\Delta V)^2$$

Consider once again the  $RL$  circuit shown below.

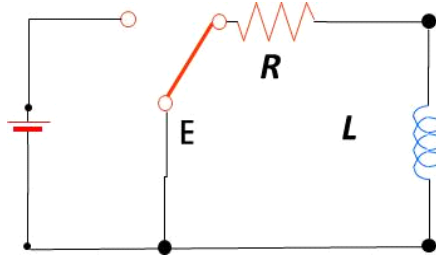

Recall that the current in the right-hand loop decays exponentially with time according to the expression

$$I = I_0 e^{-\frac{t}{\tau}}$$

where  $I_0 = \mathcal{E}/R$  is the initial current in the circuit and  $\tau = L/R$  is the time constant. As an example problem, let's show that all the energy initially stored in the magnetic field of the inductor appears as internal energy in the resistor as the current decays to zero.

Recall that energy is delivered to the resistor

$$\frac{dU}{dt} = P = I^2 R$$

where  $I$  is the instantaneous current.

$$\begin{aligned} \frac{dU}{dt} &= I^2 R \\ \frac{dU}{dt} &= \left( I_0 e^{-\frac{t}{\tau}} \right)^2 R \\ \frac{dU}{dt} &= I_0^2 e^{-2\frac{t}{\tau}} R \end{aligned}$$

To find the total energy delivered to the resistor we integrate

$$dU = I_0^2 e^{-2\frac{t}{\tau}} R dt$$

$$\int dU = \int_0^{\infty} I_o^2 e^{-2\frac{t}{\tau}} R dt$$

$$U = \int_0^{\infty} I_o^2 e^{-2\frac{t}{\tau}} R dt$$

$$U = I_o^2 R \int_0^{\infty} e^{-2\frac{t}{\tau}} dt$$

Use your calculator, or an integral table, or Maple, or Scientific Workplace or your very good memory to recall that

$$\int e^{-ax} dx = -\frac{1}{a} e^{-ax}$$

If we let

$$a = -\frac{2}{\tau}$$

then we can obtain

$$U = -\frac{L}{2R} I_o^2 R e^{-2\frac{t}{\tau}} \Big|_0^{\infty}$$

$$U = \frac{-L}{2} I_o^2 (0 - 1)$$

$$U = \frac{1}{2} I_o^2 L \quad (30.26)$$

which is the initial energy stored in the magnetic field. All of the energy that started in the inductor was delivered to the resistor.

## Mutual Induction

Suppose we have two coils near each other. If either of the coils carries a current, will there be an induced current in the other coil?

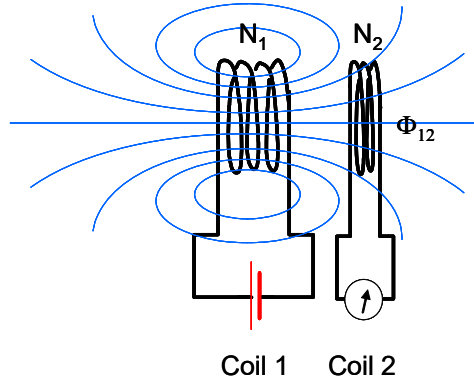

We define  $\Phi_{12}$  as the flux through coil 2 due to the current in coil 1. Likewise if the battery is placed on coil 2 we would have  $\Phi_{21}$ , the flux through coil 1 due to the current

in coil 2.

We define the mutual inductance

$$M_{12} = \frac{N_2 \Phi_{12}}{I_1} \quad (30.27)$$

BE CAREFUL! Not all books write the subscripts in the same order!

We can write the flux as

$$\Phi_{12} = \frac{M_{12} I_1}{N_2}$$

Then, using Faraday's law, we find the induced emf in coil 2

$$\begin{aligned} \mathcal{E}_2 &= -N_2 \frac{d\Phi_B}{dt} \\ &= -N_2 \frac{d}{dt} \left( \frac{M_{12} I_1}{N_2} \right) \\ &= -M_{12} \frac{d}{dt} (I_1) \end{aligned}$$

We state without proof the  $M_{12} = M_{21}$ . Then

$$\mathcal{E}_2 = -M \frac{dI_1}{dt}$$

### Example : "Wireless" battery charger



Rechargeable Toothbrush with an inductive charger (Public Domain Image courtesy Jonas Bergsten)

A rechargeable toothbrush needs a connection that is not affected by water. We can use induction to form this connection. We need two coils. One coil is the base, the other the handle. The base carries current  $I$ . The base has length  $l$  and area  $A$  and  $N_B$  turns. The handle has  $N_H$  turns and completely covers the base solenoid. What is the mutual

inductance?

Solution:

The magnetic field in the base solenoid is

$$\oint \mathbf{B} \cdot d\mathbf{s} = \mathbf{B} \ell = \mu_o N_B I$$

or

$$B = \frac{\mu_o N_B I_B}{\ell}$$

Because the handle surrounds the base, the flux through the handle is the interior field of the base. The flux is

$$\Phi_{BH} = BA$$

The mutual inductance is

$$\begin{aligned} M &= \frac{N_H \Phi_{BH}}{I_B} \\ &= \frac{N_H BA}{I_B} \\ &= \frac{N_H \left( \frac{\mu_o N_B I_B}{\ell} \right) A}{I_B} \\ &= \mu_o \frac{N_H N_B A}{\ell} \end{aligned}$$

### Example: Rectangular Loop and a coil

A rectangular loop of  $N$  close-packed turns is positioned near a long straight wire.

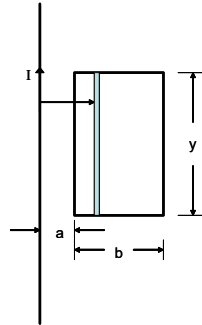

What is the coefficient of mutual inductance  $M$  for the loop-wire combination?

The basic equations are

$$M_{12} = \frac{N_2 \Phi_{12}}{I_1}$$

$$\oint \mathbf{B} \cdot d\mathbf{s} = \mu_o I$$

$$\oint \mathbf{B} \cdot d\mathbf{A} = \Phi_B$$

The field from the wire

$$\oint \mathbf{B} \cdot d\mathbf{s} = \mu_o I$$

Take the path to be a circle surrounding the wire then  $\mathbf{B}$  is constant along the path and the direction of  $\mathbf{B}$  is tangent to the path.

$$B \oint ds = \mu_o I$$

$$B 2\pi r = \mu_o I$$

or

$$B = \frac{\mu_o I}{2\pi r}$$

The flux through the rectangular loop is then perpendicular to the plane of the loop

$$\oint \mathbf{B} \cdot d\mathbf{A} = \Phi_B$$

$$\Phi_B = \int B y dr$$

$$= \int_a^{b+a} \frac{\mu_o I}{2\pi r} y dr$$

$$= \frac{\mu_o I y}{2\pi} \ln \frac{b+a}{a}$$

then

$$M = N \frac{\mu_o y}{2\pi} \ln \frac{b+a}{a}$$

Suppose the loop has  $N = 100$  turns,  $a = 1$  cm,  $b = 8$  cm,  $y = 30$  cm,  $\mu_o = 4\pi \times 10^{-7} \frac{\text{Tm}}{\text{A}}$  what is the value of the mutual inductance?

$$M = N \frac{\mu_o y}{2\pi} \ln \frac{b+a}{a} = \frac{1.3183 \times 10^{-3}}{\text{A}} \text{Tm cm} = \frac{1.3183 \times 10^{-5}}{\text{A}^2} \frac{\text{m}^2}{\text{s}^2} \text{kg}$$

$$\text{H} = \frac{1}{\text{A}^2} \frac{\text{m}^2}{\text{s}^2} \text{kg}$$

## Basic Equations





# 31 The Electromagnetic field

We started off this semester saying we would consider the environment made by a charge and how that environment affected a mover charge. Then we found that moving charges are affected by the environment created by other moving charges (currents). It is time to consider the overall environment created by both electric and magnetic fields.

## Fundamental Concepts

- The electric and magnetic fields are really different manifestations of the electromagnetic field. Which is manifest depends on our relative motion.
- The Galilean field transformations are

$$\begin{aligned}\vec{\mathbf{E}}' &= \vec{\mathbf{E}}_{\text{charges}} + \vec{\mathbf{V}}_{S'S} \times \vec{\mathbf{B}}_{\text{environment}} \\ \vec{\mathbf{B}}' &= \vec{\mathbf{B}}_{\text{magnet}} - \frac{1}{c^2} \left( \vec{\mathbf{V}}_{S'S} \times \vec{\mathbf{E}}_{\text{environment}} \right) \\ \vec{\mathbf{E}} &= \vec{\mathbf{E}}'_{\text{charges}} - \vec{\mathbf{V}}_{S'S} \times \vec{\mathbf{B}}'_{\text{environment}} \\ \vec{\mathbf{B}} &= \vec{\mathbf{B}}'_{\text{magnet}} + \frac{1}{c^2} \left( \vec{\mathbf{V}}_{S'S} \times \vec{\mathbf{E}}'_{\text{environment}} \right)\end{aligned}$$

- Gauss' law for magnetic fields is  $\oint \mathbf{B} \times d\mathbf{A} = 0$

## Relative motion and field theory

Long ago in your study of physics we talked about relative motion when we discussed moving objects and Doppler shift. We considered two reference frames with a relative velocity  $V\hat{i}$ . We called them frame  $A$  and frame  $B$

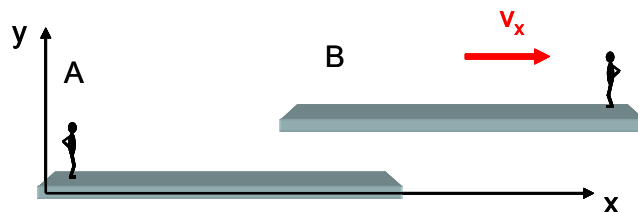

We need to return to relative motion, considering what happens when there are fields

and charged particles involved. We will need to relabel our diagram to avoid confusion because now  $B$  will represent a magnetic field. So let's call the two reference frames  $S$  and  $S'$ . We will label each axis with a prime in the  $S'$  frame.

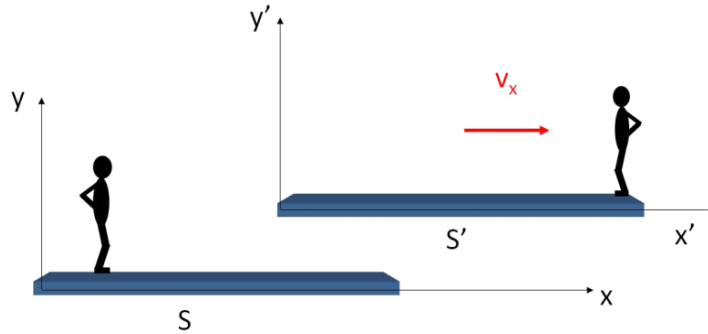

Question 223.47.1

Question 223.47.1.5

Question 223.47.2

Question 223.47.3

Now let's assume we have a magnetic field in the region of space where our two reference frames exist. Let's say that the magnetic field is stationary in frame  $S$ . This will be our environment. Let's also give a charge to the person in frame  $S'$ . This will be our mover charge.

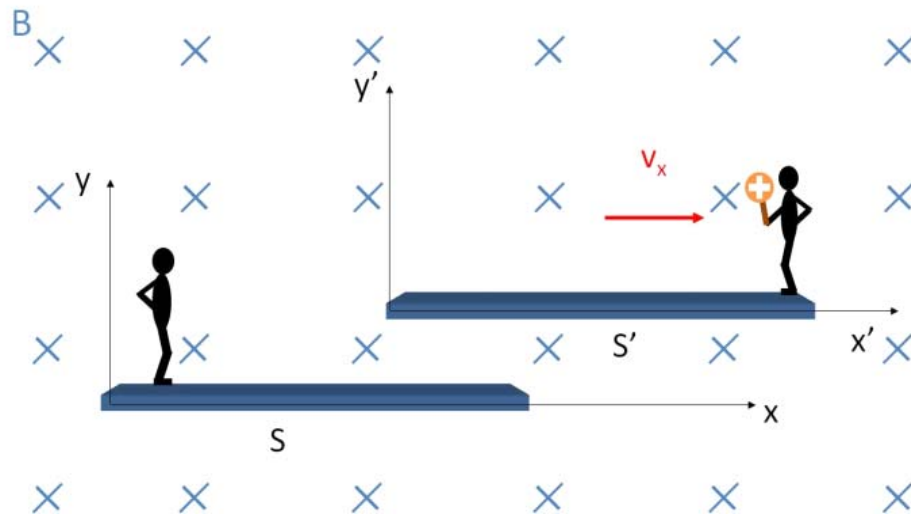

Is there a force on the charge?

If we are with the person in reference frame  $S$ , then we must say yes. The charge is

moving along with frame  $S'$  with a velocity  $\vec{v} = V\hat{i}$  so there will be a force

$$\begin{aligned}\vec{F} &= q\vec{v} \times \vec{B} \\ &= qV\hat{i} \times B(-\hat{k}) \\ &= qVB\hat{j}\end{aligned}$$

in the  $\hat{j}$  direction.

Now let's ride along with the person in frame  $S'$ . From this frame, the charge looks stationary. So  $v = 0$  and

$$F = q(\mathbf{0}) \times \vec{B} = 0$$

Both can't be true! So which is it? Is there a force on the charge or not? Consider that the existence of a force is something we can test. A force causes motion to change in ways we can detect. (the person in frame  $S'$  would *feel* the pull on the charge he is holding). So ultimately we can perform the experiment and see that there really is a force. But where does the force come from?

Let's consider our fields. We have come to see fields as the source of electric and magnetic forces. Electric forces come from electric fields which come from environmental charges. Magnetic forces come from environmental magnetic fields which come from moving charges.

And here is the difficulty, we are having trouble recognizing when the charge is moving. We know from our consideration of relative motion that we could view this situation as frame  $S'$  moving to the right with frame  $S$  stationary, or frame  $S$  moving to the left with frame  $S'$  stationary. There is no way to say that only one of these views is correct. Both are equally valid.

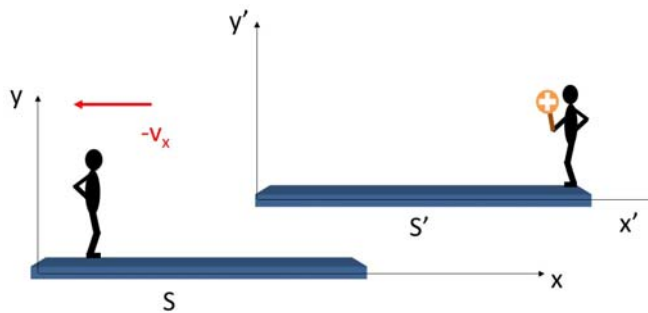

In our case, we are considering that person  $S$  sees a moving charge. We have learned that moving charge will make *both* an electric field *and* a magnetic field. This is the

situation from frame  $S$ . But person  $S'$  sees a static charge. This charge will *only* make an electric field. We need a way to resolve this apparent contradiction.

### Galilean transformation

To resolve this difficulty, let's go back to forces. Here is our case of a constant magnetic field that is stationary in frame  $S$  with a charge in frame  $S'$  again.

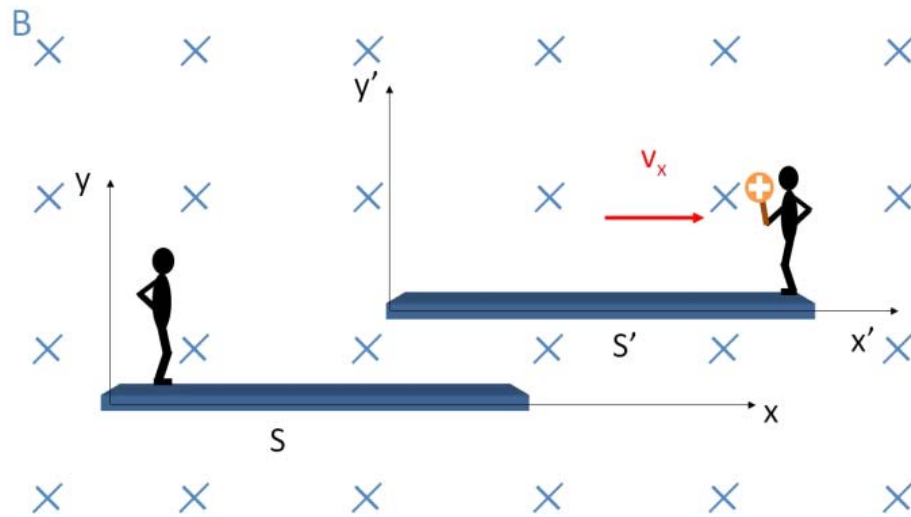

We can't see fields, but we can see acceleration of a particle. Since by Newton's second law

$$F = ma$$

we will know if there is an acceleration and therefore we will know if there is a force! So are the forces and accelerations of a charged particle the same in each frame? Let's find out.

Remember from Dynamics or PH121 that the speed of a particle transforms like this

$$\begin{aligned}\vec{v}' &= \vec{v} - \vec{V}_{S'S} \\ \vec{v} &= \vec{v}' + \vec{V}_{S'S}\end{aligned}\tag{31.1}$$

where  $V_{S'S}$  is the relative speed between the two frames. What this means is that if we have a particle moving with speed  $v'$  in frame  $S'$  and we observe this particle in frame  $S$  the speed of that particle will seem to be  $\vec{v} = \vec{v}' + \vec{V}_{S'S}$ . In our case,  $\vec{V}_{S'S} = V_x \hat{i}$  so  $\vec{v} = \vec{v}' + V_x \hat{i}$ .

A quick example might help. Suppose we have a person in the gym running on a

treadmill.

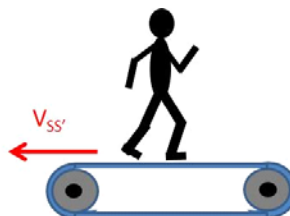

The treadmill track belt has a relative speed  $\vec{V}_{S'S} = -2\frac{m}{s}\hat{i}$  with respect to the room. We will say that the room is frame  $S$ . Then if we envision a reference frame riding along the treadmill, that would be frame  $S'$ . A person standing on the treadmill in frame  $S'$  sees themselves as not moving, and the rest of the room as moving the opposite direction.

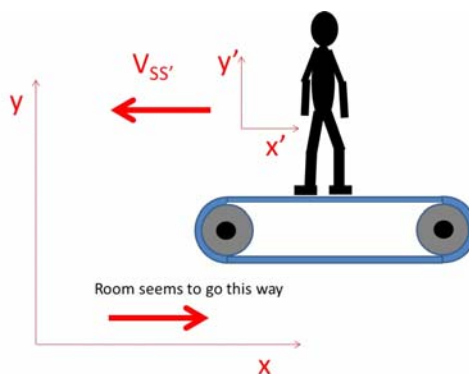

The notation  $V_{S'S}$  means the speed of the reference frame  $S'$  with respect to frame  $S$  or in our case the speed of the treadmill with respect to the room  $\vec{V}_{S'S} = -2\frac{m}{s}\hat{i}$ .

Now suppose the person is running at speed  $\vec{v}' = 1.9\frac{m}{s}\hat{i}'$  on the tread mill in the tread mill frame  $S'$ .

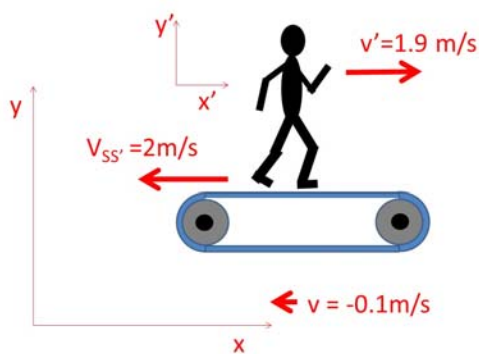

What is his/her speed with respect to the room? It seems obvious that we take the two

speeds and add them.

$$\vec{v} = 1.9 \frac{\text{m}}{\text{s}} \hat{i}' - 2 \frac{\text{m}}{\text{s}} \hat{i} = -0.1 \frac{\text{m}}{\text{s}} \hat{i}$$

since the  $i$  and  $i'$  directions are the same.

The person is going to fall off the end of the treadmill unless they pick up the pace!

This example just used the second equation in our transformation.

$$\vec{v} = \vec{v}' + \vec{V}_{S'S}$$

likewise, if we want to know how fast the person is walking with respect to the treadmill

frame, we take the room speed  $\vec{v} = -0.1 \frac{\text{m}}{\text{s}} \hat{i}$  and subtract from it the treadmill/room

relative speed  $\vec{V}_{S'S} = -2 \frac{\text{m}}{\text{s}} \hat{i}$  to obtain

$$\vec{v}' = -0.1 \frac{\text{m}}{\text{s}} \hat{i} - \left( -2 \frac{\text{m}}{\text{s}} \hat{i} \right) = 1.9 \frac{\text{m}}{\text{s}} \hat{i} = 1.9 \frac{\text{m}}{\text{s}} \hat{i}'$$

Armed with the Galilean transform, we can find the acceleration by taking a derivative

$$\begin{aligned} \frac{d\vec{v}'}{dt} &= \frac{d\vec{v}}{dt} - \frac{d\vec{V}_{S'S}}{dt} \\ \frac{d\vec{v}}{dt} &= \frac{d\vec{v}'}{dt} + \frac{d\vec{V}_{S'S}}{dt} \end{aligned}$$

then

$$\begin{aligned} \vec{a}' &= \vec{a} - \frac{d\vec{V}_{S'S}}{dt} \\ \vec{a} &= \vec{a}' + \frac{d\vec{V}_{S'S}}{dt} \end{aligned}$$

but we will only consider constant relative motion<sup>20</sup>, so

$$\frac{d\vec{V}_{S'S}}{dt} = 0$$

then both equations tell us

$$\vec{a}' = \vec{a}$$

so there *must be a force*

$$\vec{F} = m \vec{a} = m \vec{a}'$$

in both frame  $S$  and  $S'$ .

We can gain some insight into finding the mysterious missing force in frame  $S'$  by

considering the net force in the case of both an electric and a magnetic field

$$\vec{F}_{net} = q_m \vec{E} + q_m \vec{v} \times \vec{B}$$

This was first written by Lorentz, so it is called the *Lorentz force*, and is usually written

<sup>20</sup> Accelerating reference frames are treated by General Relativity and are treated with the notation of contravariant and covariant vectors, which are beyond this course. They are taken up in a graduate level electricity and magnetism course.

as

$$\vec{\mathbf{F}}_{net} = q_m (\vec{\mathbf{E}} + \vec{\mathbf{v}} \times \vec{\mathbf{B}})$$

Using this, let's consider the view point of each frame.

Going back to our two guys on different frames, In frame  $S$ , the person sees

$$\begin{aligned} \vec{\mathbf{F}} &= q_m (0 + \vec{\mathbf{V}}_{S'S} \times \vec{\mathbf{B}}) = q_m V \hat{i} \times B (-\hat{k}) \\ &= q_m V B \hat{j} \end{aligned}$$

and in frame  $S'$  the person sees

$$\vec{\mathbf{F}}' = q_m (\vec{\mathbf{E}}' + 0 \times \vec{\mathbf{B}}') = q \vec{\mathbf{E}}'$$

It seems that the only way that  $\vec{\mathbf{F}} = \vec{\mathbf{F}}'$  is that  $\vec{\mathbf{E}}' \neq 0$ . So in frame  $S'$  our person must conclude that there is an external electric field that produces the force  $\vec{\mathbf{F}}'$ . In frame  $S$  the person is convinced that the magnetic field,  $\vec{\mathbf{B}}$ , is making the force. In frame  $S'$  the person is convinced that the electric field  $\vec{\mathbf{E}}'$  is making the force.

Question 223.47.4

We can find the strength of this electric field by setting the forces equal

$$\begin{aligned} \vec{\mathbf{F}} &= \vec{\mathbf{F}}' \\ q \vec{\mathbf{V}}_{S'S} \times \vec{\mathbf{B}} &= q \vec{\mathbf{E}}' \end{aligned}$$

so

$$\vec{\mathbf{E}}' = \vec{\mathbf{V}}_{S'S} \times \vec{\mathbf{B}}$$

and the direction must be

$$\vec{\mathbf{E}}' = V_{S'S} B \hat{j}$$

Question 223.47.5

Question 223.47.6

Our interpretation of this result is mind-blowing. It seems that whether we see a magnetic field or an electric field depends on our reference frame! The implication is that the electric and magnetic fields are not really two different things. They are one field viewed from different reference frames!

So far we have been talking about external fields only. The field  $\vec{\mathbf{B}}$  in our case study is created by some outside agent. So the field  $\vec{\mathbf{E}}'$  observed in frame  $S'$  is also an environmental field. But the charge, itself, creates a field. So the total electric field in frame  $S'$  is the environmental field  $\vec{\mathbf{E}}'$  plus the field due to the charge, itself  $\vec{\mathbf{E}}_{self}$ , or

$$\begin{aligned} \vec{\mathbf{E}}'_{tot} &= \vec{\mathbf{E}}_{self} + \vec{\mathbf{E}}'_{environment} \\ &= \vec{\mathbf{E}}_{self} + \vec{\mathbf{V}}_{S'S} \times \vec{\mathbf{B}}_{environment} \end{aligned}$$

which we usually just write as

$$\vec{\mathbf{E}}' = \vec{\mathbf{E}}_{self} + \vec{\mathbf{V}}_{S'S} \times \vec{\mathbf{B}}_{environment}$$

We would predict that if we had a charge that is stationary in frame  $S$  and we rode

along with frame  $S'$  that we would see a field

$$\vec{E} = \vec{E}'_{\text{self}} - \vec{V}_{S'S} \times \vec{B}'_{\text{environment}}$$

Of course,  $\vec{E}'_{\text{self}}$  can't create a force on the charge, because it is a self-field. So we only need to be concerned with  $\vec{E}'_{\text{self}}$  if we have other charges that could move. We could actually have other charges riding along with frame  $S'$ . In that case we would have an additional field  $E'_{\text{charge}}$ . We could write this as

$$\vec{E} = \vec{E}'_{\text{charges in } S'} - \vec{V}_{S'S} \times \vec{B}'_{\text{environment}}$$

or just

$$\vec{E} = \vec{E}'_{\text{charges}} - \vec{V}_{S'S} \times \vec{B}'_{\text{environment}}$$

What we have developed is important! We have an equation that let's us determine the electric field in a frame, given the fields measured in another frame.

We would expect that a similar thing would happen if we replaced the magnetic fields with electric fields. Suppose we have an electric field in the region of our frames and that this electric field is stationary with respect to frame  $S'$  this time. Will frame  $S$  see a magnetic field?

Question 223.47.7

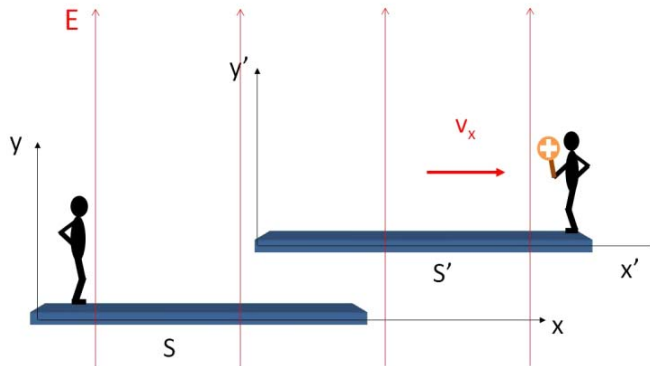

To see that this is true, let's examine the case where we have no external fields, and we just have a charge moving along with frame  $S'$ . Then in frame  $S'$  we have the fields

$$\begin{aligned} \vec{E}' &= \frac{1}{4\pi\epsilon_0} \frac{q}{r^2} \hat{r} \\ \vec{B}' &= 0 \end{aligned}$$



in frame  $S$  the electric field is

$$\begin{aligned}\vec{\mathbf{E}} &= \vec{\mathbf{E}}'_{\text{charges}} - \vec{\mathbf{V}}_{S'S} \times \vec{\mathbf{B}}'_{\text{environment}} \\ &= \frac{1}{4\pi\epsilon_o} \frac{q}{r^2} \hat{\mathbf{r}} + \vec{\mathbf{V}}_{S'S} \times \mathbf{0} \\ &= \frac{1}{4\pi\epsilon_o} \frac{q}{r^2} \hat{\mathbf{r}}\end{aligned}$$

so

$$\vec{\mathbf{E}} = \vec{\mathbf{E}}' = \frac{1}{4\pi\epsilon_o} \frac{q}{r^2} \hat{\mathbf{r}}$$

We see the same electric field due to the point charge being there in both frames.

But in frame  $S$  we are expecting the person to see a magnetic field because to person  $S$  the charge is moving. Using the Biot-Savart law

$$\vec{\mathbf{B}} = \frac{\mu_o}{4\pi} \frac{q \vec{\mathbf{v}} \times \hat{\mathbf{r}}}{r^2}$$

since our charge is moving along with the  $S'$  frame  $\vec{\mathbf{v}} = \vec{\mathbf{V}}_{S'S}$  so

$$\vec{\mathbf{B}} = \frac{\mu_o}{4\pi} \frac{q}{r^2} (\vec{\mathbf{V}}_{S'S} \times \hat{\mathbf{r}})$$

but we can rewrite this by rearranging terms

$$\begin{aligned}\vec{\mathbf{B}} &= \frac{\mu_o}{4\pi} \frac{q}{r^2} (\vec{\mathbf{V}}_{S'S} \times \hat{\mathbf{r}}) \\ &= \left( \vec{\mathbf{V}}_{S'S} \times \frac{\mu_o}{4\pi} \frac{q}{r^2} \hat{\mathbf{r}} \right)\end{aligned}$$

which looks vaguely familiar. Let's multiply top and bottom by  $\epsilon_o$

$$\begin{aligned}\vec{\mathbf{B}} &= \left( \vec{\mathbf{V}}_{S'S} \times \frac{\mu_o \epsilon_o}{4\pi \epsilon_o} \frac{q}{r^2} \hat{\mathbf{r}} \right) \\ &= \left( \vec{\mathbf{V}}_{S'S} \times \mu_o \epsilon_o \left( \frac{1}{4\pi \epsilon_o} \frac{q}{r^2} \hat{\mathbf{r}} \right) \right) \\ &= \left( \vec{\mathbf{V}}_{S'S} \times \mu_o \epsilon_o (\vec{\mathbf{E}}') \right) \\ &= \mu_o \epsilon_o (\vec{\mathbf{V}}_{S'S} \times \vec{\mathbf{E}}')\end{aligned}$$

which is really quite astounding! Our  $B$ -fields have apparently always just been due to moving electric fields after all!

Of course, we could have an additional magnet riding along with frame  $S'$ . To allow for that case, let's include a term  $\vec{\mathbf{B}}'_{\text{magnet}}$ .

$$\vec{\mathbf{B}} = \vec{\mathbf{B}}'_{\text{magnets in } S'} + \mu_o \epsilon_o (\vec{\mathbf{V}}_{S'S} \times \vec{\mathbf{E}}'_{\text{environment}})$$

or just

$$\vec{\mathbf{B}} = \vec{\mathbf{B}}'_{\text{magnets}} + \mu_o \epsilon_o (\vec{\mathbf{V}}_{S'S} \times \vec{\mathbf{E}}'_{\text{environment}})$$

and we would expect that if we worked this problem from the other frame's point of

view we would likewise find

$$\vec{\mathbf{B}}' = \vec{\mathbf{B}}_{\text{magnet}} - \mu_o \epsilon_o \left( \vec{\mathbf{V}}_{S'S} \times \vec{\mathbf{E}}_{\text{environment}} \right)$$

where the minus sign comes from the relative velocity being in the other direction. Again  $\vec{\mathbf{B}}_{\text{magnet}}$  is a self-field. It won't move itself, but might be important if we have a second magnet in our experiment. Then  $\vec{\mathbf{B}}_{\text{magnet}}$  would cause a force on this second magnet.

Once again we have found a way to find a field, the magnetic field this time, in one frame if we know the fields on another frame! We call this sort of equation a *transformation*.

We should take a moment to look at the constants  $\mu_o \epsilon_o$ . Let's put in their values

$$\begin{aligned} \mu_o \epsilon_o &= \left( 8.85 \times 10^{-12} \frac{\text{C}^2}{\text{N m}^2} \right) \left( 4\pi \times 10^{-7} \frac{\text{T m}}{\text{A}} \right) \\ &= 1.1121 \times 10^{-17} \frac{\text{s}^2}{\text{m}^2} \end{aligned}$$

This is a very small number, and it may not appear to be interesting. We can see that the additional magnetic fields due to the movement of the charges can be quite small unless the electric field is large or the relative speed is large (or both). So much of the time this additional field due to the moving charge is negligible. But let's calculate

$$\begin{aligned} \frac{1}{\sqrt{\mu_o \epsilon_o}} &= \frac{1}{\sqrt{\left( 8.85 \times 10^{-12} \frac{\text{C}^2}{\text{N m}^2} \right) \left( 4\pi \times 10^{-7} \frac{\text{T m}}{\text{A}} \right)}} \\ &= 2.9986 \times 10^8 \frac{\text{m}}{\text{s}} \\ &= c \end{aligned}$$

This is the speed of light! It even has units of m/s. This seems an amazing coincidence—too amazing. And this was one of the clues that Maxwell used to discover that light is a wave in what we will now call (because they are different aspects of one thing) the *electromagnetic field*.

We can write the transformation equations for the fields as

$$\begin{aligned} \vec{\mathbf{E}}' &= \vec{\mathbf{E}}_{\text{charges}} + \vec{\mathbf{V}}_{S'S} \times \vec{\mathbf{B}}_{\text{environment}} \\ \vec{\mathbf{B}}' &= \vec{\mathbf{B}}_{\text{magnet}} - \frac{1}{c^2} \left( \vec{\mathbf{V}}_{S'S} \times \vec{\mathbf{E}}_{\text{environment}} \right) \\ \vec{\mathbf{E}} &= \vec{\mathbf{E}}'_{\text{charges}} - \vec{\mathbf{V}}_{S'S} \times \vec{\mathbf{B}}'_{\text{environment}} \\ \vec{\mathbf{B}} &= \vec{\mathbf{B}}'_{\text{magnet}} + \frac{1}{c^2} \left( \vec{\mathbf{V}}_{S'S} \times \vec{\mathbf{E}}'_{\text{environment}} \right) \end{aligned}$$

Let's do a problem. Suppose we have a metal loop moving into an area where there is

a magnetic field as shown. Let's show that there is a force on charges in this loop no matter what frame we consider. First, let's consider the frame where the magnetic field is stationary and the loop moves.

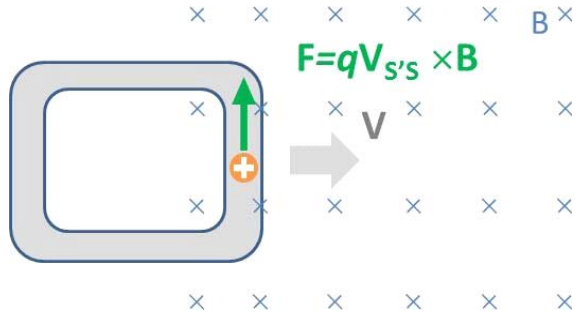

There should be an upward force on the positive charge because the charge is moving in a magnetic field. Let's say that "up" is the  $\hat{j}$  direction and that "to the right" is the  $\hat{i}$  direction. Then The Lorentz force is

$$\begin{aligned} \vec{\mathbf{F}} &= q(\vec{\mathbf{E}} + \vec{\mathbf{v}} \times \vec{\mathbf{B}}) \\ &= q(\vec{\mathbf{E}} + \vec{\mathbf{V}}_{S'S} \times \vec{\mathbf{B}}) \end{aligned}$$

Now  $\vec{\mathbf{V}}_{S'S}$  means the speed of the reference frame  $S'$  with respect to frame  $S$ . That is  $+V\hat{i}$ . And there is no electric field in frame  $S$ , so

$$\begin{aligned} \vec{\mathbf{F}} &= q(\vec{\mathbf{E}} + \vec{\mathbf{V}}_{S'S} \times \vec{\mathbf{B}}) \\ &= q(0 + V\hat{i} \times B(-\hat{k})) \\ &= q(V\hat{i} \times B(-\hat{k})) \\ &= qVB\hat{j} \end{aligned}$$

Now suppose we change reference frames so we are riding along with the loop in frame,  $S'$ . In this frame, the loop is not moving, and the magnetic field is moving by us the opposite direction. We'll call this the "prime frame." We should get the same force if we change frames to ride along with the loop.

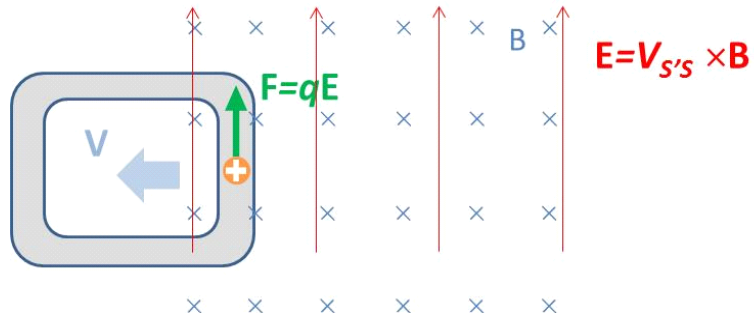

Let's use our transformations to find the  $E$  and  $B$ -fields in the new reference frame.

Then

$$\begin{aligned}\vec{\mathbf{E}}' &= \vec{\mathbf{E}}_{\text{self-charge}} + \vec{\mathbf{V}}_{S'S} \times \vec{\mathbf{B}}_{\text{environment}} \\ \vec{\mathbf{B}}' &= \vec{\mathbf{B}}_{\text{magnet}} - \frac{1}{c^2} \left( \vec{\mathbf{V}}_{S'S} \times \vec{\mathbf{E}}_{\text{environment}} \right)\end{aligned}$$

so in the prime frame we have an electric field

$$\vec{\mathbf{E}}' = \vec{\mathbf{E}}_{\text{charges}} + \vec{\mathbf{V}}_{S'S} \times \vec{\mathbf{B}}_{\text{environment}}$$

and in particular, we have an external field

$$\vec{\mathbf{E}}'_{\text{environment}} = \vec{\mathbf{V}}_{S'S} \times \vec{\mathbf{B}}_{\text{environment}}$$

(we left off the  $\vec{\mathbf{E}}_{\text{charge}}$  because it can't move the charge that made it, so it is not part of the force).

Note that  $\vec{\mathbf{V}}_{S'S}$  is the speed of the primed frame as viewed from the unprimed frame.

So  $\vec{\mathbf{V}}_{S'S} = +V\hat{i}$

$$\begin{aligned}\vec{\mathbf{E}}' &= V(\hat{i}) \times B(-\hat{k}) \\ &= VB\hat{j}\end{aligned}$$

That is our electric field in the primed frame.

The magnetic field in the primed frame is given by

$$\vec{\mathbf{B}}' = \vec{\mathbf{B}}_{\text{magnet}} - \frac{1}{c^2} \left( \vec{\mathbf{V}}_{S'S} \times \vec{\mathbf{E}}_{\text{environment}} \right)$$

but there is no external electric field in the unprimed frame, so

$$\begin{aligned}\vec{\mathbf{B}}' &= \vec{\mathbf{B}}_{\text{magnet}} - \frac{1}{c^2} \left( \vec{\mathbf{V}}_{S'S} \times 0 \right) \\ &= \vec{\mathbf{B}}_{\text{magnet}}\end{aligned}$$

where here “magnet” means what ever is making the magnetic field in the unprimed frame. Something must be there making the field, and it is not our charge. It could be an electromagnet, or a permanent magnet, we have not been told). But it is not our charge, so we know  $\vec{\mathbf{B}}_{\text{magnet}}$  must be there and can act on our charge. So

$$\vec{\mathbf{B}}' = \vec{\mathbf{B}}$$

The magnetic field in the primed frame is just the same as the magnetic field we see in the unprimed frame. Then in the primed frame the Lorentz force is

$$\begin{aligned}\vec{\mathbf{F}}' &= q \left( \vec{\mathbf{E}}' + \vec{\mathbf{v}} \times \vec{\mathbf{B}}' \right) \\ &= q \left( VB\hat{j} + \mathbf{0} \times \vec{\mathbf{B}} \right) \\ &= qVB\hat{j}\end{aligned}$$

Which is exactly the same force (magnitude and direction) as we got in the unprimed frame.

## Field Laws

A “law” in physics is a mathematical statement of a physical principal or theory. We have been collecting laws for what we will now call the *electromagnetic field theory*. Let’s review:

### Gauss’ law

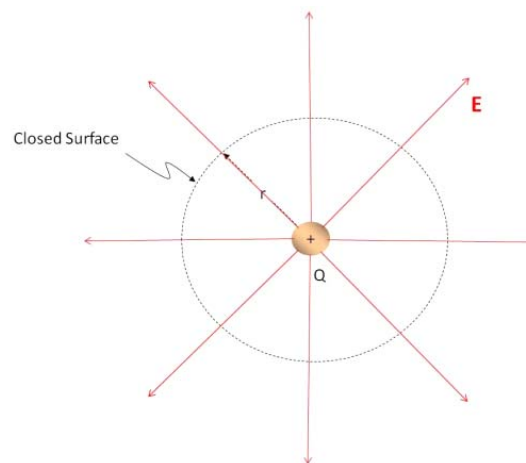

We found that the electric flux through an imaginary closed surface that incloses some charge is

$$\Phi_E = \oint \mathbf{E} \cdot d\mathbf{A} = \frac{Q_{in}}{\epsilon_0}$$

We called this Gauss’ law.

Question 223.47.8

But consider the situation with a magnet. We can define a magnetic flux just like we defined the electric flux. And now we know they must be related. Is there a Gauss’ law for magnetism? Let’s consider the magnetic flux.

$$\Phi_B = \oint \mathbf{B} \cdot d\mathbf{A}$$

This should be proportional to the number of “magnetic charges” inclosed in the surface.

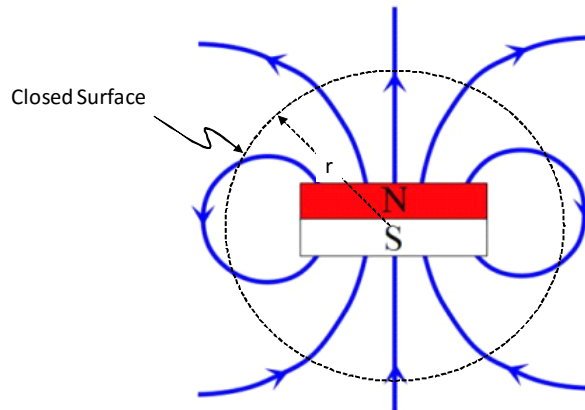

We can see that every field line that leaves comes back in. That is how we defined zero net flux, so

$$\Phi_B = \oint \mathbf{B} \cdot d\mathbf{A} = 0$$

Which would tell us that there are no free “magnetic charges” or no single magnetic poles. A single magnetic pole is called a *monopole* and indeed we have never discovered one. These two forms of Gauss’ law form the first two of our electromagnetic field equations.

The differences between them have to do with the fact that magnetic fields are due to moving charges.

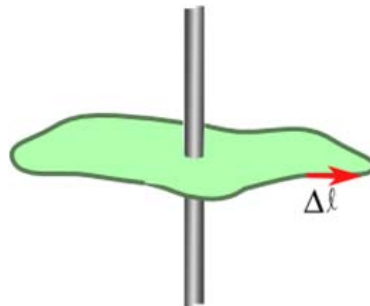

We have a third electromagnetic field law, Ampere’s law. We found Ampere’s law by integrating around a closed loop with a current penetrating the loop.

$$\oint \mathbf{B} \cdot d\mathbf{s} = \mu_0 I_{\text{through}}$$

We also know Faraday's law

$$\mathcal{E} = \oint \mathbf{E} \cdot d\mathbf{s} = -\frac{d\Phi_B}{dt}$$

which told us that changing magnetic fields created an electric field. We have found that the opposite must be true, that a changing electric field must create a magnetic field. We express this as

$$\oint \mathbf{B} \cdot d\mathbf{s} \propto \frac{d\Phi_E}{dt}$$

Which gives two expressions for  $\oint \mathbf{B} \cdot d\mathbf{s}$ . But we have yet to show that this equation is true. That is the subject of our next lecture. If we can accomplish this, we will have a complete set of field equations that describe how the electromagnetic field works. In the following lecture we will complete the set of field equations, and then in the next lecture we will show that we get electromagnetic waves from these equations.

## Basic Equations

Rules for finding fields in different coordinate systems

$$\vec{\mathbf{E}}' = \vec{\mathbf{E}}_{\text{charges}} + \vec{\mathbf{V}}_{S'S} \times \vec{\mathbf{B}}_{\text{environment}}$$

$$\vec{\mathbf{B}}' = \vec{\mathbf{B}}_{\text{magnet}} - \frac{1}{c^2} \left( \vec{\mathbf{V}}_{S'S} \times \vec{\mathbf{E}}_{\text{environment}} \right)$$

$$\vec{\mathbf{E}} = \vec{\mathbf{E}}'_{\text{charges}} - \vec{\mathbf{V}}_{S'S} \times \vec{\mathbf{B}}'_{\text{environment}}$$

$$\vec{\mathbf{B}} = \vec{\mathbf{B}}'_{\text{magnet}} + \frac{1}{c^2} \left( \vec{\mathbf{V}}_{S'S} \times \vec{\mathbf{E}}'_{\text{environment}} \right)$$

Gauss' law for magnetic fields

$$\Phi_B = \oint \mathbf{B} \times d\mathbf{A} = 0$$





# 32 Field Equations and Waves in the Field

We started this class with a study of waves. We learned about optics, and finally electromagnetic field theory. In this lecture we will take on a case study that involves all three. We will have come full circle and in the process, hopefully understand all three topics a little better.

## Fundamental Concepts

- Changing electric fields produce magnetic fields
- A changing electric flux is described as a displacement current  $I_d = \epsilon_o \frac{d\Phi_E}{dt}$
- The complete version of Ampere's law is  $\oint \mathbf{B} \cdot d\ell = \mu_o (I + I_d)$
- Maxwell's equations give a complete classical picture of electromagnetic fields
- Maxwell's equations plus the Lorentz force describe all of electrodynamics.
- Maxwell's equations lead directly to the linear wave equation for both the electric and the magnetic field with the speed of light being the speed of the waves.
- The magnitude of the  $E$  and  $B$  fields are related in an electromagnetic wave by  $E_{\max} = cB_{\max}$

## Displacement Current

Last time we listed Ampere's law as one of the basic field equations. But we did not discuss it at all. That is because we were saving it for our discussion in this lecture. We need to look deeply into Ampere's law. Here is what we have for Ampere's law so far

$$\oint \mathbf{B} \cdot d\mathbf{s} = \mu_o I_{\text{through}}$$

To see why we need to consider it further, let's do a hard problem with Ampere's law. Let's set up a circuit with a battery with a switch and a circular plate capacitor in the wire.

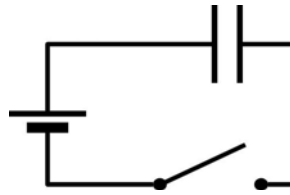

Using this circuit, let's calculate the magnetic field using Ampere's law. Here is a detailed diagram of the capacitor.

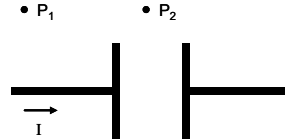

I could find the magnetic field using the Biot-Savart equation, but that would be hard. I don't know how to solve the resulting integral. So let's try Ampere's law. Let's start at  $P_1$ . We add in an imaginary surface at  $P_1$ . I will choose a simple circular surface.

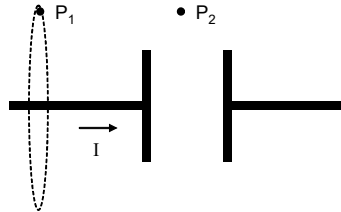

We have done this before. If we choose  $P_1$  so that it is far from the capacitor, then we know what the magnetic field will look like.

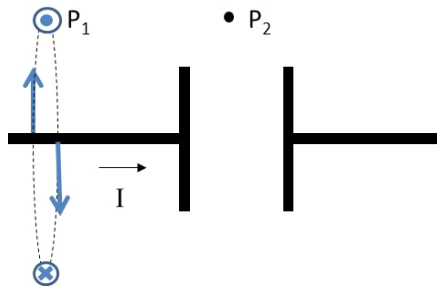

Right at  $P_1$  it will be out of the page. We also know that for a long straight wire, the field magnitude does not change as we go around the wire, so we can write our integral as

$$\oint \mathbf{B} \cdot d\ell = B \oint d\ell = B2\pi r = \mu_o I$$

so

$$B2\pi r = \mu_o I$$

so the field is

$$B = \frac{\mu_o I}{2\pi r}$$

Question 223.48.1

which is very familiar, just the equation for a field from a long straight wire.

Now Let's try this at  $P_2$ . What would we expect? Will the magnetic field change much as we pass by the capacitor?

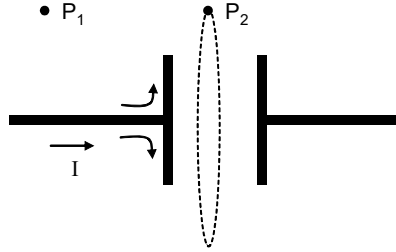

Again we could use Biot-Savart, but think about what the current does at the plate. It would be very hard to do the integration!. So again let's try Ampere's law. If we use the same size surface

$$\oint \mathbf{B} \cdot d\ell = B \oint d\ell = B2\pi r$$

but this is equal to  $\mu_o I_{through}$ . There is no  $I$  going through the capacitor! so

$$B2\pi r = 0 \tag{32.1}$$

and this would give  $B = 0$ . But, our wires are not really ideal and infinitely long. And even if they were, would we really expect the field to be zero if we just have a small gap in our capacitor? It get's even worse!

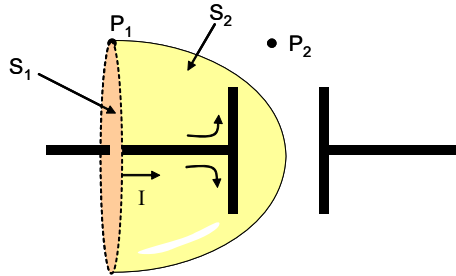

Ampere's law tells us we need a surface, but it does not say it has to be a circular surface. In fact, we could use the strange surface labeled  $S_2$  in the figure above. This is a perfectly good surface to associate with the loop at  $P_1$ . So this gives us

$$\oint \mathbf{B} \cdot d\ell = \mu_o I = 0$$

at  $P_1$ ! So we have two different results with Ampere's law for the same point. This can't be!

Question 223.48.2

Ampere knew this was a problem, but did not find a solution. Maxwell solved this. He asked himself, what was different inside the capacitor that might be making a difference. Of course, there is an electric field inside the capacitor!

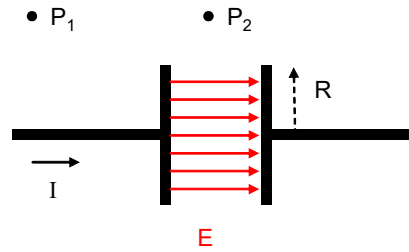

We know that in the limit that the plates can be considered to be very big the field is approximately

$$E = \frac{\eta}{\epsilon_o} = \frac{Q}{\pi R^2 \epsilon_o}$$

but we know that the charge is changing in time once the switch is thrown. We can find the rate of change of the field, then

$$\frac{dE}{dt} = \frac{1}{\pi R^2 \epsilon_o} \frac{dQ}{dt}$$

By definition

$$I = \frac{dQ}{dt}$$

is a current, but what current? It must be the current that is supplying the charge to the capacitor. That current is what is changing the  $Q$  in the capacitor, and it is the  $Q$  separation that is making the field. So the time derivative of the electric field is

$$\frac{dE}{dt} = \frac{I}{\pi R^2 \epsilon_o}$$

where  $I$  is the current in the wire, and only if the wire current is zero will there be no change in the electric field.

This gives us an idea. A changing electric field creates a magnetic field. Suppose this changing electric field created a magnetic field like the current does? It would be as though there were a current with a value

$$I_d = \pi R^2 \epsilon_o \frac{dE}{dt} \tag{32.2}$$

Note that in this we have the area of the plate,  $A_{plate} = \pi R^2$  multiplied by the time rate of change of the electric field. Also note, that in our approximation for our capacitor, there is only an electric field inside the plates. So, remembering electric flux,

$$\Phi_E = \int \mathbf{E} \cdot d\mathbf{A}$$

our flux through the surface at  $P_2$  would be

$$\begin{aligned} \Phi_E &= EA \\ &= \pi R^2 E \end{aligned}$$

so we can identify

$$\pi R^2 dE = A_{plate} dE = d\Phi_E$$

as a small amount of *electric flux*. Then our equivalent current will be

$$I_d = \epsilon_o \frac{d\Phi_E}{dt} \quad (32.3)$$

Maxwell decided that, since this looked like equivalent to a current, he would call it a current and include it in Ampere's law.

$$\begin{aligned} \oint \mathbf{B} \cdot d\ell &= \mu_o (I + I_d) \\ &= \mu_o \left( I + \epsilon_o \frac{d\Phi_E}{dt} \right) \end{aligned}$$

Question 223.48.3

but remember it is not really a current. What we have is a changing electric field that is making a magnetic field *as though there were a current*  $I_d$ . We can try this on our capacitor problem. We have done our capacitor problem for  $S_1$  where we expect  $\frac{d\Phi_E}{dt} \approx 0$  so our original calculation stands

$$B_{S_1} = \frac{\mu_o I}{2\pi r}$$

but now we know that if we use  $S_2$  we have  $\frac{d\Phi_E}{dt} \neq 0$ , and we realize that at  $P_2$  the current  $I = 0$  so

$$\oint \mathbf{B} \cdot d\ell = \mu_o \left( 0 + \epsilon_o \frac{d\Phi_E}{dt} \right)$$

and for our geometry we found  $\frac{d\Phi_E}{dt}$

$$\oint \mathbf{B} \cdot d\ell = \mu_o \left( 0 + \pi R^2 \epsilon_o \frac{dE}{dt} \right)$$

and we calculated  $\frac{dE}{dt}$  so we can substitute it in

$$\oint \mathbf{B} \cdot d\ell = \mu_o \left( 0 + \pi R^2 \epsilon_o \frac{I}{\pi R^2 \epsilon_o} \right)$$

where we remember that the current  $I$  is the current making the electric field—the current in the wire. Then we have

$$B 2\pi r = \mu_o (0 + I)$$

and our field is

$$B = \frac{\mu_o I}{2\pi r}$$

which is just what we found using  $S_1$ . Maxwell seems to have saved the day! There is no dip in the magnetic field magnitude.

There is one more fix we will have to do to Ampere's law eventually. We found this form of Ampere's law with the capacitor empty—not even containing air. But we could do the same derivation with a dielectric filled capacitor. We also could have magnetic materials involved.

But what we have done so far is really a momentous result. We have shown that, indeed, we should have an equation that provides symmetry with Faraday's law. We suspected

that

$$\oint \mathbf{B} \cdot d\mathbf{s} \propto \frac{d\Phi_E}{dt}$$

and we can write the constants of proportionality as

$$\oint \mathbf{B} \cdot d\mathbf{s} = \mu_o \epsilon_o \frac{d\Phi_E}{dt}$$

but because we have  $\oint \mathbf{B} \cdot d\mathbf{s}$  also in Ampere's law, we can combine the two to yield

$$\begin{aligned} \oint \mathbf{B} \cdot d\mathbf{s} &= \mu_o (I + I_d) \\ &= \mu_o \left( I + \epsilon_o \frac{d\Phi_E}{dt} \right) \end{aligned}$$

This is the last of our field equations. It is called the Maxwell-Ampere law.

Let's use this to solve for the magnetic field inside the capacitor. A changing electric field will make a magnetic field.

Take a surface inside the plates that is a circle of radius  $r < R$ . Then

$$\oint \mathbf{B} \cdot d\mathbf{s} = B2\pi r$$

and from our modified Ampere's equation

$$\begin{aligned} \oint \mathbf{B} \cdot d\mathbf{s} &= \mu_o (I + I_d) \\ &= \mu_o \left( I + \epsilon_o \frac{d\Phi_E}{dt} \right) \end{aligned}$$

so

$$\begin{aligned} B2\pi r &= \mu_o \left( 0 + \epsilon_o \frac{d\Phi_E}{dt} \right) \\ &= \pi r^2 \mu_o \epsilon_o \frac{dE}{dt} \\ &= \pi r^2 \mu_o \epsilon_o \frac{I}{\pi R^2 \epsilon_o} \\ &= \mu_o \frac{r^2 I}{R^2} \end{aligned}$$

so

$$B = \mu_o \frac{rI}{2\pi R^2} \quad (32.4)$$

We should pause to realize what we have just done. We have shown that, indeed, a changing electric field can produce a magnetic field. This statement is a profound look at the way the universe works!

## Maxwell Equations

We have developed a powerful set of understanding equations for electricity and magnetism. Maxwell summarized our knowledge in a series of four equations

$$\begin{aligned}
 \oint \mathbf{E} \cdot d\mathbf{A} &= \frac{Q_{in}}{\epsilon_0} && \text{Gauss's law for electric fields} \\
 \oint \mathbf{B} \cdot d\mathbf{A} &= 0 && \text{Gauss's law for magnetic fields} \\
 \oint \mathbf{E} \cdot d\mathbf{s} &= -\frac{d\Phi_B}{dt} && \text{Faraday's law} \\
 \oint \mathbf{B} \cdot d\mathbf{s} &= \mu_0 I + \epsilon_0 \mu_0 \frac{d\Phi_E}{dt} && \text{Ampere-Maxwell Law}
 \end{aligned} \tag{32.5}$$

If we have a dielectric, we might see these written as[?]

$$\begin{aligned}
 \oint \mathbf{E} \cdot d\mathbf{A} &= \frac{Q_{in}}{\epsilon_0 \kappa} && \text{Gauss's law for electric fields} \\
 \oint \mathbf{B} \cdot d\mathbf{A} &= 0 && \text{Gauss's law for magnetic fields} \\
 \oint \mathbf{E} \cdot d\mathbf{s} &= -\frac{d\Phi_B}{dt} && \text{Faraday's law} \\
 \oint \mathbf{B} \cdot d\mathbf{s} &= \mu_0 \kappa_m \left( I + \epsilon_0 \kappa \frac{d\Phi_E}{dt} \right) && \text{Ampere-Maxwell Law}
 \end{aligned} \tag{32.6}$$

Since we have all had multivariate calculus, we may also see these written as

$$\begin{aligned}
 \nabla \cdot \mathbf{E} &= \frac{\rho}{\epsilon_0} && \text{Gauss's law for electric fields} \\
 \nabla \cdot \mathbf{B} &= 0 && \text{Gauss's law for magnetic fields} \\
 \nabla \times \mathbf{E} &= -\frac{d\mathbf{B}}{dt} && \text{Faraday's law} \\
 c^2 \nabla \times \mathbf{B} &= \frac{\mathbf{J}}{\epsilon_0} + \frac{d\mathbf{E}}{dt} && \text{Ampere-Maxwell Law}
 \end{aligned} \tag{32.7}$$

I'll let you remember the process to do the translation from  $\oint \mathbf{B} \cdot d\mathbf{A}$  to  $\nabla \cdot \mathbf{B}$ .

But we are familiar with all of these equations now. These four equations are the basis of all of classical electrodynamics. In an electromagnetic problem, we find the fields using the Maxwell equations to find the fields, and then apply the fields to find the Lorentz forces

$$\mathbf{F} = q\mathbf{E} + q\mathbf{v} \times \mathbf{B} \tag{32.8}$$

It turns out that these four equations strongly imply that there can be waves in the fields. We will see this in our next lecture. We already know from our study of optics that these waves are what we call light.





# 33 Electromagnetic waves

## Turning the Maxwell Equations into Differential Equations

Maxwell took the hint that  $\mu_0\epsilon_0$  was related to  $c$ , the speed of light and he thought that light might be a wave in the electromagnetic field. We know about waves. We can describe a wave by looking for a surface of constant amplitude—a wave crest. A point source will cause spherical surfaces of constant amplitude. A half-wave antenna makes a toroidal shaped wave front. We will not deal with spherical or worse wave shapes. Unfortunately, many antennas send out complicated wave patterns that take spherical harmonics to describe well. That is beyond the math we want to do in this course.

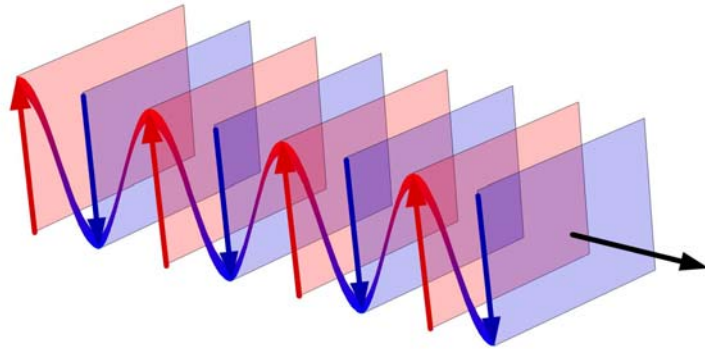

A representation of a plane wave. Remember that the planes are really of infinite extent. Image is public domain.

Instead, let's picture our wave front far from the source. No matter what the total shape, if we look at a small patch of the fields far away, they will look like the plane wave in the last figure. Since this is a useful and common situation (except if you use lasers), we will perform some calculations assuming plane wave geometry.

We will assume we are in empty space, so the charge  $q$  and current  $I$  will both be zero.

Then our Maxwell Equations become

$$\begin{aligned}
 \oint \vec{\mathbf{E}} \cdot d\vec{\mathbf{A}} &= 0 && \text{Gauss's law for electric fields} \\
 \oint \vec{\mathbf{B}} \cdot d\vec{\mathbf{A}} &= 0 && \text{Gauss's law for magnetic fields} \\
 \oint \vec{\mathbf{E}} \cdot d\vec{\mathbf{s}} &= -\frac{d\Phi_B}{dt} && \text{Faraday's law} \\
 \oint \vec{\mathbf{B}} \cdot d\vec{\mathbf{s}} &= \epsilon_o \mu_o \frac{d\Phi_E}{dt} && \text{Ampere-Maxwell Law}
 \end{aligned}
 \tag{33.1}$$

Our goal is to show that these equations tell us that we can have waves in the field. To do this, we will show that Maxwell's equations really contain the linear wave equation within them. As a reminder, here is the linear wave equation

Far Board

$$\frac{\partial^2 y}{\partial x^2} = \frac{1}{v^2} \frac{\partial^2 y}{\partial t^2}$$

it is a second order differential equation where the left side derivatives are taken with respect to position, and the right side derivatives are taken with respect to time. The quantity,  $v$ , is the wave speed. In this form of the equation  $y$  is the displacement of a medium. Our medium will be the electromagnetic field.

### Rewriting of Faraday's law

Skip this

Let's start with Faraday's law

$$\oint \vec{\mathbf{E}} \cdot d\vec{\mathbf{s}} = -\frac{d\Phi_B}{dt} \tag{33.2}$$

Given our geometry, we can say the wave is traveling in the  $x$  direction with the  $\vec{\mathbf{E}}$  field positive in the  $y$  direction and the magnetic field is positive in the  $z$  direction.

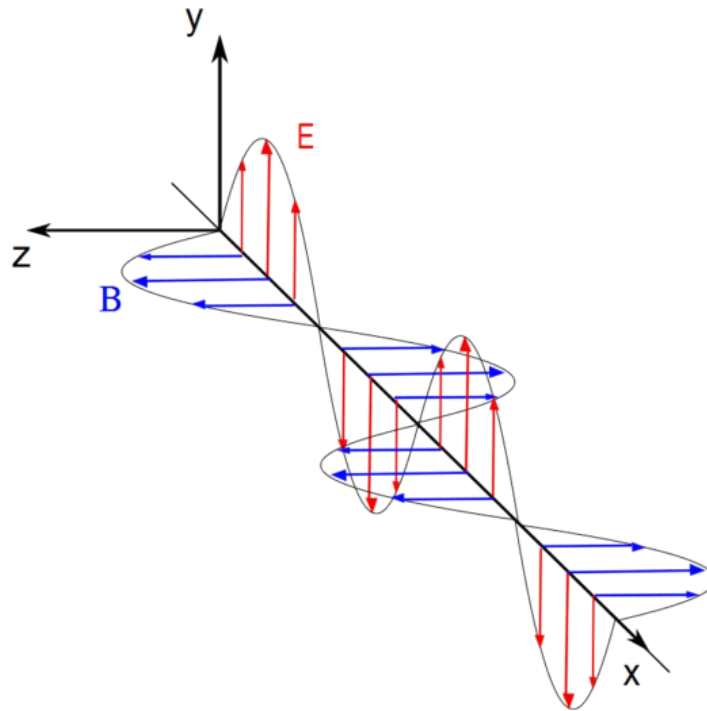

Let's take a small rectangle of area to find  $\oint \vec{E} \cdot d\vec{s}$

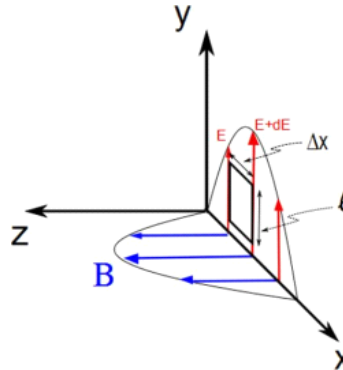

The top and bottom of the rectangle don't contribute because  $\vec{E} \cdot d\vec{s} = 0$  along these paths. On the sides, the field is either in the  $d\vec{s}$  or it is in the opposite direction. So

$$\oint \vec{E} \cdot d\vec{s} = \oint E ds$$

or

$$\oint \vec{E} \cdot d\vec{s} = -\oint E ds$$

along the sides. Let's say we travel counter-clockwise along the loop. Then the left side will be negative and the right side will be positive.

$$\oint \vec{\mathbf{E}} \cdot d\vec{\mathbf{s}} = \int_{right} E ds - \int_{left} E ds$$

On the left side, we are at a position  $x$  away from the axis, and on the right side we are a position  $x + \Delta x$  away from the axis. Then the field of the left side is  $E(x, t)$  and the field on the right hand side is approximately

$$E(x + \Delta x, t) \approx E(x, t) + \frac{\partial E}{\partial x} \Delta x \quad (33.3)$$

so if our loop is small, then  $\ell$  is small and  $E$  won't change much so we can write approximately

$$\oint \vec{\mathbf{E}} \cdot d\vec{\mathbf{s}} = \int_{right} E ds - \int_{left} E ds \quad (33.4)$$

$$\approx E(x + \Delta x, t) \ell - E(x, t) \ell \quad (33.5)$$

$$= \left( E(x, t) + \frac{\partial E}{\partial x} \Delta x \right) \ell - E(x, t) \ell$$

$$= \left( E(x, t) + \frac{\partial E}{\partial x} \Delta x \right) \ell - E(x, t) \ell$$

$$= \ell \frac{\partial E}{\partial x} \Delta x \quad (33.6)$$

So far then, Faraday's law <sup>21</sup>

$$\oint \vec{\mathbf{E}} \cdot d\vec{\mathbf{s}} = -\frac{d\Phi_B}{dt}$$

becomes

$$\ell \frac{\partial E}{\partial x} \Delta x = -\frac{d\Phi_B}{dt}$$

Let's move on to the right hand side of Faraday's law. We need to find  $\Phi_B$  so that we can find the time rate of change of the flux. We can say that  $B$  is nearly constant over such a small area, so

$$\begin{aligned} \Phi_B &= \mathbf{B} \cdot \mathbf{A} \\ &= BA \cos \theta \\ &= BA \\ &= B\ell\Delta x \end{aligned}$$

where here  $\Delta x$  means "a small distance" as it did above. Then

$$\begin{aligned} \frac{d\Phi_B}{dt} &= \frac{d}{dt} (B\ell\Delta x) \\ &= \ell\Delta x \left. \frac{dB}{dt} \right|_{x \text{ constant}} \\ &= \ell\Delta x \frac{\partial B}{\partial t} \end{aligned}$$

where we have held  $x$  constant because we are not changing our small area, so

<sup>21</sup> We need  $ds$  to be very small, much smaller than the wavelength of the wave.

Faraday's law

$$\oint \vec{E} \cdot d\vec{s} = -\frac{d\Phi_B}{dt}$$

becomes

$$\begin{aligned} \ell \frac{\partial E}{\partial x} \Delta x &= -\ell \Delta x \frac{\partial B}{\partial t} \\ \frac{\partial E}{\partial x} &= -\frac{\partial B}{\partial t} \end{aligned} \quad (33.7)$$

We have made some progress, we have a differential equation relating the fields, but it is a mixed equation containing both the electric and magnetic fields. We are only half way there.

## Rewriting of the Maxwell-Ampere Law

We have used one field equation so far and that took us part of the way. We have the Maxwell-Ampere law as well. We can use this to modify our result from Faraday's law to find the linear wave equation that we expect. The Maxwell-Ampere law with no sources (charges or currents) states

$$\oint \vec{B} \cdot d\vec{s} = \epsilon_0 \mu_0 \frac{d\Phi_E}{dt}$$

This time we must consider the magnetic field path integral

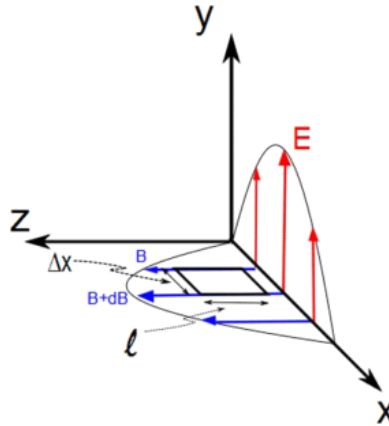

We can do the same thing we did with Faraday's law with an area, but this time we will use the area within the magnetic field (shown in the figure above). Again, let's start with the left hand side of the equation. We see that the sides of our area that are parallel to the  $x$ -axis do not matter because  $\vec{B} \cdot d\vec{s} = 0$  along these sides, but the other two are in

the direction (or opposite direction) of the field. They do contribute to the line integral.

$$\begin{aligned}\oint \vec{\mathbf{B}} \cdot d\vec{\mathbf{s}} &= B(x, t)\ell - B(x + \Delta x, t)\ell \\ &\approx -\ell \frac{\partial B}{\partial x} \Delta x\end{aligned}\quad (33.8)$$

Now for the left hand side, we need the electric flux. For such a small area, the field is nearly constant so

$$\begin{aligned}\Phi_E &\approx EA \cos \theta \\ &= EA \\ &= E\ell\Delta x\end{aligned}$$

so

$$\frac{\partial \Phi_E}{\partial t} = \ell \Delta x \frac{\partial E}{\partial t} \quad (33.9)$$

Combining both sides

$$\begin{aligned}\oint \vec{\mathbf{B}} \cdot d\vec{\mathbf{s}} &= \varepsilon_o \mu_o \frac{d\Phi_E}{dt} \\ -\ell \frac{\partial B}{\partial x} \Delta x &= \varepsilon_o \mu_o \ell \Delta x \frac{\partial E}{\partial t} \\ \frac{\partial B}{\partial x} &= -\varepsilon_o \mu_o \frac{\partial E}{\partial t}\end{aligned}\quad (33.10)$$

We now have a second differential equation relating  $B$  and  $E$ . But it is also a mixed differential equation.

## Wave equation for plane waves

This leaves us with two equations to work with

$$\frac{\partial E}{\partial x} = -\frac{\partial B}{\partial t} \quad (33.11)$$

$$\frac{\partial B}{\partial x} = -\varepsilon_o \mu_o \frac{\partial E}{\partial t} \quad (33.12)$$

Remember that these are all partial derivatives. Taking the derivative of the first equation with respect to  $x$  gives

$$\begin{aligned}\frac{\partial}{\partial x} \frac{\partial E}{\partial x} &= \frac{\partial}{\partial x} \left( -\frac{\partial B}{\partial t} \right) \\ \frac{\partial^2 E}{\partial x^2} &= -\frac{\partial}{\partial x} \left( \frac{\partial B}{\partial t} \right) \\ \frac{\partial^2 E}{\partial x^2} &= -\frac{\partial}{\partial t} \left( \frac{\partial B}{\partial x} \right)\end{aligned}$$

In the last equation we swapped the order of differentiation for the right hand side. In parenthesis, we have  $\partial B/\partial x$  on the right hand side. But we know what  $\partial B/\partial x$  is from our second equation. We substitute from our second equation to obtain

$$\frac{\partial^2 E}{\partial x^2} = - \frac{\partial}{\partial t} \left( -\epsilon_o \mu_o \frac{\partial E}{\partial t} \right)$$

$$\frac{\partial^2 E}{\partial x^2} = \epsilon_o \mu_o \frac{\partial^2 E}{\partial t^2} \quad (33.13)$$

We can do the same thing, but taking derivatives with respect to time to give

$$\frac{\partial^2 B}{\partial x^2} = \epsilon_o \mu_o \frac{\partial^2 B}{\partial t^2} \quad (33.14)$$

You will recognize both of these last equations as being in the form of the linear wave equation.

$$\frac{\partial^2 y}{\partial x^2} = \frac{1}{v^2} \frac{\partial^2 y}{\partial t^2}$$

This means that both the  $E$  field and the  $B$  field are governed by the linear wave equation with the speed of the waves given by

$$v = \frac{1}{\sqrt{\epsilon_o \mu_o}} \quad (33.15)$$

We have studied waves, so we know the solution to this equation is a sine or cosine function

$$E = E_{\max} \cos(kx - \omega t) \quad (33.16)$$

$$B = B_{\max} \cos(kx - \omega t) \quad (33.17)$$

with

$$k = \frac{2\pi}{\lambda}$$

and

$$\omega = 2\pi f$$

then

$$\frac{\omega}{k} = \frac{2\pi f}{\frac{2\pi}{\lambda}} = \lambda f$$

which is the wave speed.

We can show that the magnitude of  $E$  is related to  $B$ .

Lets take derivatives of  $E$  and  $B$  with respect to  $x$  and  $t$ .

$$\frac{\partial E}{\partial x} = -k E_{\max} \sin(kx - \omega t)$$

$$\frac{\partial B}{\partial t} = \omega B_{\max} \sin(kx - \omega t)$$

then we can use one of our half-way-point equations from above

$$\frac{\partial E}{\partial x} = - \frac{\partial B}{\partial t}$$

and by substitution obtain

$$\begin{aligned} -kE_{\max} \sin(kx - \omega t) &= -\omega B_{\max} \sin(kx - \omega t) \\ -kE_{\max} &= -\omega B_{\max} \end{aligned}$$

or

$$\frac{E_{\max}}{B_{\max}} = \frac{\omega}{k} = v$$

The speed is the speed of light,  $c$ , so

$$\frac{E_{\max}}{B_{\max}} = c \quad (33.18)$$

It is one of the odd things about the universe that speed of electromagnetic waves is a constant. It does not vary in vacuum, and the in-vacuum value,  $c$  is the maximum speed. It was a combination of Maxwell's work in predicting  $c$  and the observations confirming the predictions that launched Einstein to form the Special Theory of Relativity!

Note that the last equation shows why we often only deal with the electric field wave when we do optics. Since the magnetic field is proportional to the electric field, we can always find it from the electric field.

## Properties of EM waves

Pick up here

Knowing that the electric and magnetic fields form plane waves, we can investigate these plane wave solutions to see what they imply.

### Energy in an EM wave

The electromagnetic (EM) wave is a wave. Waves transfer energy. It is customary find a vector that describes the flow of energy in the electromagnetic wave. This is like the ray vectors we have been drawing for some time, but with the magnitude of the vector giving the energy flow rate.

The rate of at which energy travels with the EM wave is given the symbol  $\mathbf{S}$  and is called the Poynting vector after the person who thought of it. It is

$$\mathbf{S} = \frac{1}{\mu_0} \mathbf{E} \times \mathbf{B} \quad (33.19)$$

Let's deal with a dumb name first: The Poynting vector. It is named after a scientist with the last name Poynting. The name is really meaningless. There is nothing particularly "pointy" about this vector more than any other vector.

Instead of a formal derivation, let's just see what we get from Poynting's equation for a



plane wave.

For our plane wave case,  $E$  and  $B$  are at  $90^\circ$  angles<sup>22</sup>. so

$$S = \frac{1}{\mu_o} EB \quad (33.20)$$

and  $S$  will be perpendicular to both. Notice from our preceding figures that this is also the direction that the wave travels! That is comforting. That should be true for a EM wave. The energy, indeed, goes the way the Poynting vector points.

Using

$$\frac{E}{B} = c$$

we can write the magnitude of the Poynting vector as

$$S = \frac{E^2}{c\mu_o} \quad (33.21)$$

We could also express this in terms of  $B$  only.

You will remember that our eyes don't track the oscillations of the electromagnetic waves. Few detectors (if any) can. For visible light, the frequency is very high. We usually see a time average. This time average of the Poynting vector is called the *intensity* of the wave

$$I = S_{ave}$$

## Intensity of the waves

When we studied waves, we learned that waves have an intensity. The intensity of electromagnetic waves must relate to the strength of the fields. We can write it as

$$I = \frac{EB}{2\mu_o}$$

(can you remember where the "1/2" came from?)<sup>23</sup>. Again using

$$E = cB$$

we can write the intensity as

$$I = \frac{1}{2\mu_o c} E^2 \quad (33.22)$$

We remember that  $I$  is proportional to the square of the maximum electric field strength from our previous consideration of light intensity. But before we only said that it was proportional. Now we know the constant of proportionality. Of course we could also

<sup>22</sup> For other fields this might not be true, but it is generally true for light.

<sup>23</sup> This is because the average value of  $\sin^2(\omega t)$  over a period is given by  $\frac{1}{T} \int_0^T \sin^2(\omega t) dt = \frac{\omega}{2\pi} \int_0^{\frac{2\pi}{\omega}} \sin^2(\omega t) dt = \frac{1}{2}$

write the intensity as

$$I = \frac{c}{2\mu_o} B^2 \quad (33.23)$$

but this is less traditional. We have said already that the intensity,  $I$ , is the magnitude of the average Poynting vector  $S_{ave}$ .

Recall that we know the energy densities in the fields

$$\begin{aligned} u_E &= \frac{1}{2} \epsilon_o E^2 \\ u_B &= \frac{1}{2} \frac{B^2}{\mu_o} \end{aligned}$$

again, since

$$E = cB \quad (33.24)$$

we can write

$$\begin{aligned} u_B &= \frac{1}{2} \frac{B^2}{\mu_o} \\ &= \frac{1}{2} \frac{E^2}{c^2 \mu_o} \\ &= \frac{1}{2} \epsilon_o E^2 \end{aligned} \quad (33.25)$$

so for a plane electromagnetic wave

$$u_E = u_B \quad (33.26)$$

The total energy in the field is just the sum

$$u = u_E + u_B = \epsilon_o E^2 \quad (33.27)$$

But when we do the time average to find the intensity, we pick up a factor of a half

$$u_{ave} = \frac{1}{2} \epsilon_o E^2 \quad (33.28)$$

Comparing this to our equation for intensity gives

$$I = \frac{1}{2\mu_o c} E_{\max}^2 = S_{ave}$$

and then

$$\begin{aligned} S_{ave} &= \frac{1}{\epsilon_o \mu_o c} \frac{1}{2} \epsilon_o E^2 \\ &= \frac{1}{\epsilon_o \mu_o c} u_{ave} \\ &= \frac{1}{\frac{1}{c^2} c} u_{ave} \\ &= c u_{ave} \end{aligned} \quad (33.29)$$

Remember when you studied thermodynamics you, learned that we could transfer energy by radiation. This is our radiation! And we see that it does indeed transfer energy. We learned about this by discussing solar heating and by talking about Army

weapons that apply energy to crowds.



but we really use this every day when we microwave something. Microwaves are electromagnetic waves!

## Momentum of light

One of the strangest things is that there is also momentum in the electromagnetic waves. If the waves are absorbed, the momentum is

$$p = \frac{U}{c} \quad (33.30)$$

or if the waves are reflected it is

$$p = \frac{2U}{c} \quad (33.31)$$

(think of balls bouncing off a wall, the change in momentum is always  $2mv$ ).

We can think of the light exerting a pressure on the surface. Force is given by

$$\begin{aligned} F &= ma \\ &= m \frac{dv}{dt} \\ &= \frac{dp}{dt} \end{aligned}$$

then using this force, the pressure is

$$P = \frac{F}{A} = \frac{1}{A} \frac{dp}{dt} \quad (33.32)$$

then

$$P = \frac{F}{A} = \frac{1}{cA} \frac{dU}{dt} \quad (33.33)$$

We found  $\frac{1}{A} \frac{dU}{dt}$  to be the energy rate per unit area, which is the magnitude of the

Poynting vector,  $S$ . So our pressure due to light is

$$P = \frac{S}{c} \quad (33.34)$$

for perfect absorption. If there is perfect reflection

$$P = \frac{2S}{c} \quad (33.35)$$

This may seem a little strange. Water or sound waves would exert a pressure because the water or air particles can strike a surface, exerting a force. But remember the electromagnetic fields will create forces on the electrons in atoms<sup>24</sup>, and most of the electrons are bound to the atoms in materials by the Coulomb force. So there really is a force on the material due to the electromagnetic wave. Quantum mechanics tells us about electrons being knocked out of shells into higher energy shells (absorbing photons of light) and re-emitting the light when the electrons fall back down to lower shells. This is a little like catching a frisbee, and then throwing it. Momentum is transferred both at the catch and at the release.

A cool use of this phenomena is called laser levitation



Figure 33.8. Laser Levitation (Skigh Lewis, Larry Baxter, Justin Peatross (BYU), Laser Levitation: Determination of Particle Reactivity, ACERC Conference Presentation, February 17, 2005)

In the picture you are seeing a single small particle that is floating on a laser beam. the laser beam is directed upward. The force due to gravity would make the particle fall,

<sup>24</sup> Protons too, but the protons are more tightly bound due to the nuclear strong force and the nuclei are bound in the material. their resonant frequencies are usually not assessable to visible light, so I will ignore their effect in our treatment. But if you consider x-rays or gamma rays, they would be important.

but the laser light keeps it up!

### Antennas Revisited

We talked about antennas before. Let's try to put all we have done together to make a radio wave. First, we know from our analysis that we need changing fields. Neither static charges, nor constant currents will do. If we think about this for a minute, we will realize that the charges will *accelerate*. Fundamentally, this is the mechanism for making EM waves.

The half wave antenna is simple to understand, so let's take it as our example.

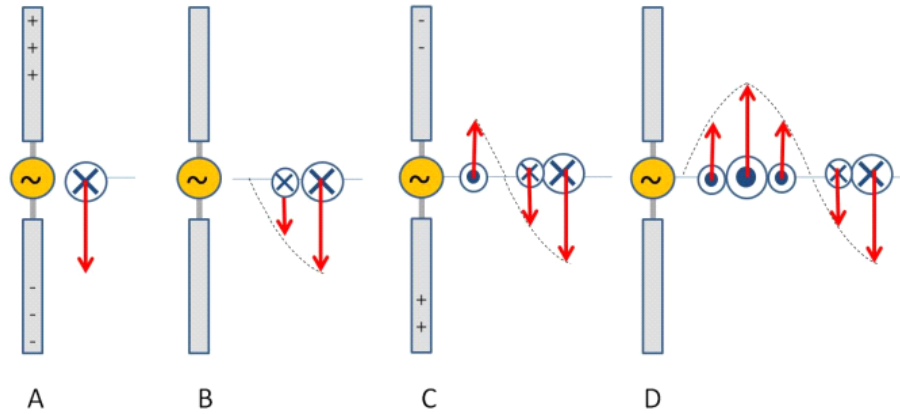

It is made from two long wires connected to an alternating current source (the radio transmitter). The charges are separated in the antenna as shown. But the separation switches as the alternating current changes direction. The charges accelerate back and forth, like a dipole switching direction. Radio people call this antenna a *simple dipole*.

Note the direction of the  $E$  and  $B$  fields. The Poynting vector is to the right. The antenna field sets up a situation far from the antenna, itself, where the changing electric field continually induces a magnetic field and the changing magnetic field continually induces a changing electric field. The wave becomes self sustaining! And the energy it carries travels outward.

Below you can see a graph of the sort of toroidal angular dependence of the dipole antenna emission pattern.

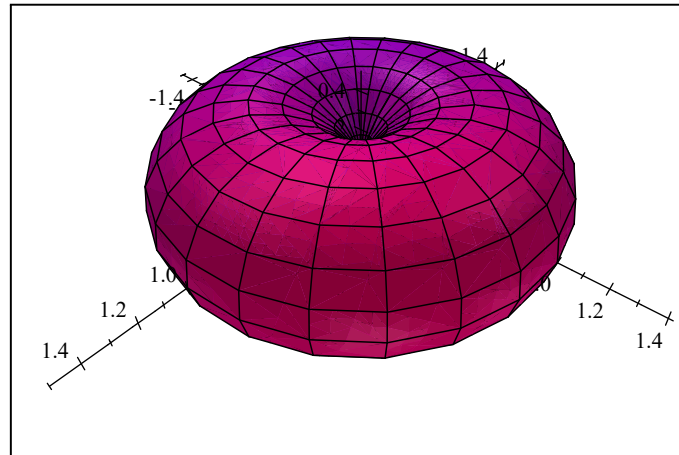

Angular dependence of  $S$  for a dipole scatterer.

From this you can see why we usually stand antennas straight up and down. Then the transmission travels parallel to the Earth's surface, where receivers are more likely to be.

Speaking of receivers, of course the receiver works like a transmitter, only backwards. The EM waves that hit the receiving antenna accelerate the electrons in the wire of the antenna. The induced current passed through an LRC circuit whose resonance frequency allows amplification of just one small band of frequencies (the one your favorite radio station is using) and then the amplified signal is sent to a speaker.

## The Electromagnetic Spectrum

Maxwell predicted how fast his field waves would travel by finding the linear wave equation from the fields and noticing the speed indicated by the result. We have seen how he did this. The answer is

$$v = \frac{1}{\sqrt{\epsilon_0 \mu_0}} \quad (33.36)$$

this speed is so special in physics that it gets its own letter

$$c = 2.99792 \times 10^8 \frac{\text{m}}{\text{s}} \quad (33.37)$$

which is of course the speed of light. In fact, that this was the measured speed of light was strong evidence leading us to conclude that light was really a type of these waves. There are a few more types of electromagnetic waves. In the following chart you can see that visible light is just a small part of what we call the *electromagnetic spectrum*.

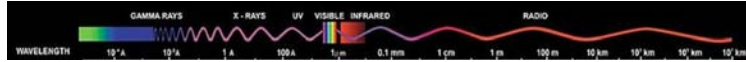

Electromagnetic Spectrum (Public Domain image courtesy NASA)

The speed of light is always a constant in vacuum. This is strange. It caused a lot of problems when it was discovered.

$$v = f\lambda \tag{33.38}$$

or

$$c = f\lambda \tag{33.39}$$

where we can see that for light and electromagnetic waves, knowing the wavelength is always enough to know the frequency as well (in a vacuum).

As an example of what problems can come, let's consider a Doppler effect for light. Remember for sound waves, we had a Doppler effect. We will have a Doppler effect for electromagnetic waves too. But light does not change its speed relative to a reference frame. This is *really weird*. The speed of light in a vacuum is *always c—no matter what frame we measure it in*.

Einstein's theory of Special Relativity is required to deal with this constant speed of light in every reference frame. From Relativity, the Doppler equation is

$$f' = f \frac{\sqrt{1 + \frac{v}{c}}}{\sqrt{1 - \frac{v}{c}}} \tag{33.40}$$

or, if we let  $u$  be the relative velocity between the source and the detector, and insist that  $u \ll c$

$$f' = f \left( \frac{c + u}{c} \right) \tag{33.41}$$

Where of course  $f'$  is the observed frequency and  $f$  is the frequency emitted by the source. This is usually written as

$$f' = f \left( 1 \pm \frac{u}{c} \right) \tag{33.42}$$

but it is really the same equation<sup>25</sup>. Just like with sound, we use the positive sign when the source and observer are approaching each other.

This means that if things are moving closer to each other the frequency increases. Think of

$$\lambda = \frac{c}{f} \tag{33.43}$$

this means that as a source and emitter approach each other, then the light will have a shorter wavelength. Think of our chart on the electromagnetic spectrum. This means the

<sup>25</sup> This equation is only really true for relative speeds  $u$  that are much less than the speed of light. Since it is very hard to make something travel even close to the speed of light, we will find it is nearly always true.

light will get bluer. If they move farther apart, the light will get redder.

This is what gave us the hint that has led to our cosmological theories like the big bang. Although this theory is now much more complicated, the facts are that as we look at far away objects, we see they are all *red shifted*. That is, they all show absorption spectra for known elements, but at longer wavelengths than we expect from laboratory experiments. We interpret this as meaning they are all going away from us!

## Summary

Here is what we have learned so far about the properties of light

1. Electromagnetic waves travel at the speed of light
2. Electromagnetic waves are transverse electric and magnetic waves that are oriented perpendicular to each other.
3.  $E = cB$
4. Electromagnetic waves carry energy *and momentum*

## Photons

Our understanding of light is not complete yet. If you went on to take PH279 you would find that light still operates much like a particle at times. This should not be a surprise, since Newton and others explained much of optics (the study of light) assuming light was a particle.

Einstein and others noticed that for some metals, light would strike the surface and electrons would leave the surface. The energy of a wave is proportional to the amplitude of the wave. It was expected that if the amplitude of the electromagnetic wave was increased, the number of electrons leaving the surface would increase. This proved to be true most of the time. But Hertz and others decided to try different frequencies of light. It turns out that as you lower the frequency, all of a sudden no electrons leave no matter how big the amplitude of the wave. Something was wrong with our wave theory of light. The answer came from Einstein who used the idea of a “packet” of light to explain this *photoelectric effect*. For now, we should know just that the waves of light exist in *quantized* packets called *photons*. The energy of a photon is

$$E = hf \quad (33.44)$$



where  $E$  is the energy,  $f$  is the frequency of the light wave, and  $h$  is a constant

$$h = 6.63 \times 10^{-34} \text{ J s} \quad (33.45)$$

A beam of light is many, many photons all superimposing. We know how waves combine using superposition, so it is easy to see that we can get a big wave from many little waves.

Knowing that light is made from electric and magnetic fields, and that these fields are vector fields, we should expect some directional quality in light. And there is such a directional quality that we will study next lecture.



# 34 Polarization

## Fundamental Concepts

- The direction of the electric field in a plane wave is called the polarization direction.
- Natural light is usually a superposition of many waves with random polarization directions. This light is called unpolarized light.
- Some materials allow light with one polarization to pass through, while stopping other polarizations. The polaroid is one such material. Polaroids will have a final intensity that follows the relationship  $I = I_{\max} \cos^2(\theta)$
- Light reflecting off a surface may be polarized because of the absorption and re-emission pattern of light interacting with the material atoms.
- Scattered light may be polarized because of anisotropies in the scatterers.
- Birefringent materials have different wave speeds in different directions. This affects the polarization of light entering these materials.

## Polarization of Light Waves

We said much earlier in our study of light that it was a transverse wave. Last lecture we saw that we have an electric and magnetic field direction, and that these directions are perpendicular to each other and the direction of energy flow. We will now show some implications of this fact. In a course in electromagnetic theory, we often draw light as in the figure below.

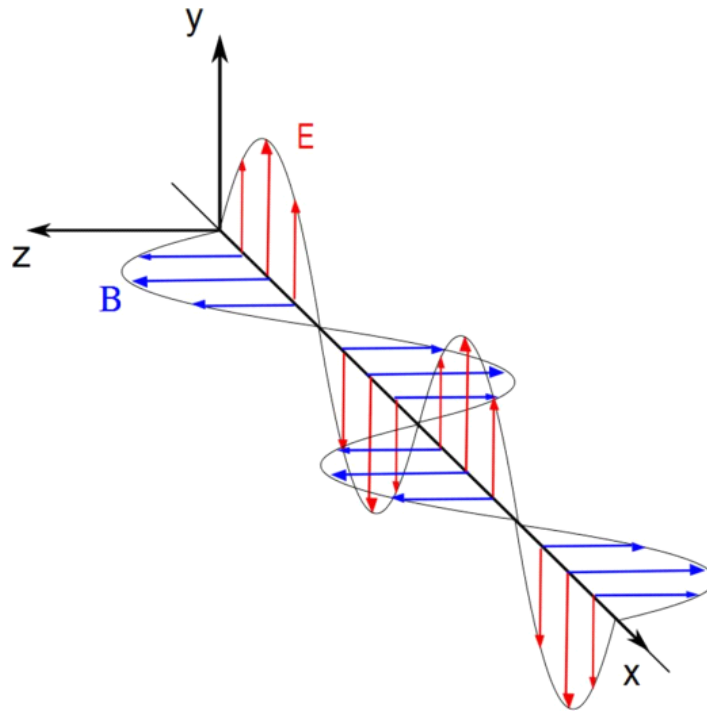

We will continue to ignore the magnetic field (marked in the figure as  $B$ ). We will look at the  $E$  field and notice that it goes up and down in the figure. But we could have light in any orientation. If we look directly at an approaching beam of light we would “see” many different orientations as shown in the next figure.

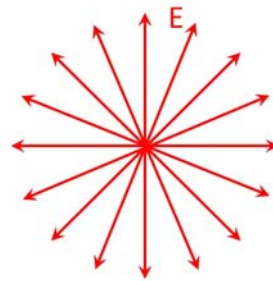

When light beams have waves with many orientations, we say they are *unpolarized*. But suppose we were able to align all the light so that all the waves in the beam were transverse waves in the same orientation. Say, the one in the next figure.



Then we would describe the light as *linearly polarized*. The plane that contains the  $E$ -field is known as the *polarization plane*.

### Polarization by removing all but one wave orientation

One way to make polarized light is to remove all but one orientation of an unpolarized beam. A material that does this at visible wavelengths is called a *polaroid*. It is made of long-chain hydrocarbons that have been treated with iodine to make them conductive. The molecules are all oriented in one direction by stretching during the manufacturing process. The molecules have electrons that can move when light hits them. They can move farther in the long direction of the molecule, so in this direction the molecules act like little antennas. The molecules' electrons are driven into harmonic motion along the length of the molecule. This takes energy (and therefore, light) out of the beam. Little electron motion is possible in the short direction of the molecule, so light is given a preferential orientation. The light is passed if it is perpendicular to the long direction of the molecules. This direction is called the *transmission axis*.

We can take two pieces of polaroid material to study polarization.

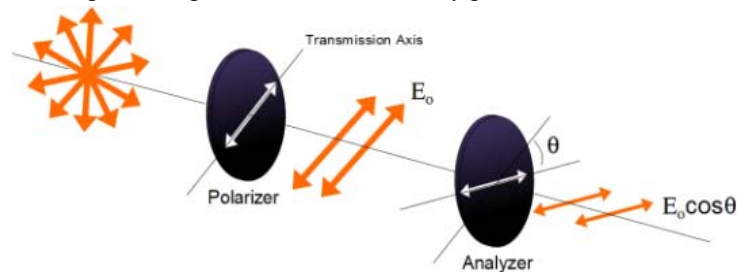

Unpolarized light is initially polarized by the first piece of polaroid called the *polarizer*. The second piece of polaroid then receives the light. This piece is called the *analyzer*. If

there is an angular difference in the orientation of the transmission axes of the polarizer and analyzer, there will be a reduction of light through the system. We expect that if the transmission axes are separated by  $90^\circ$  no light will be seen. If they are separated by  $0^\circ$ , then there will be a maximum. It is not hard to believe that the intensity will be given by

$$I = I_{\max} \cos^2(\theta) \quad (34.1)$$

remembering that we must have a squared term because  $I \propto E^2$ .

### Polarization by reflection

If we look at light reflected off of a desk or table through a piece of polaroid, we can see that at some angles of orientation, the reflection diminishes or even disappears! Light is often polarized on reflection. Let's consider a beam of light made of just two polarizations. We will define a plane of incidence. This plane is the plane of the paper or computer screen. This plane is perpendicular to the reflective or refractive surface in the figure below.

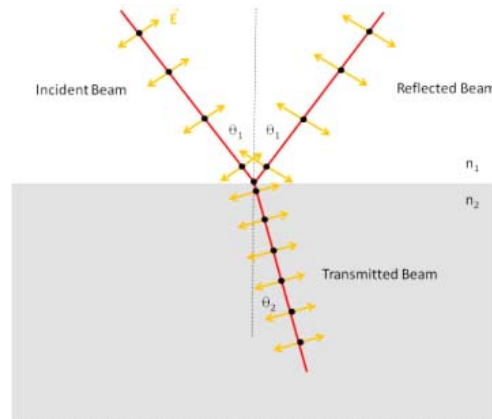

One of our polarizations is defined as parallel to this plane. This direction is represented by orange (lighter grey in black and white) arrows in the figure. The other polarization is perpendicular to the plane of incidence (the plane of the paper). This is represented by the black dots in the figure. These dots are supposed to look like arrows coming out of the paper.

When the light reaches the interface between  $n_1$  and  $n_2$  it drives the electrons in the medium into SHM. The perpendicular polarization finds electrons that are free to move in the perpendicular direction and re-radiate in that direction. Even for a dielectric, the

electron orbitals change shape and oscillate with the incoming electromagnetic wave.

The parallel ray is also able to excite SHM, but a electromagnetic analysis tells us that these little “antennas” will not radiate at an angle  $90^\circ$  from their excitation direction. Think of little dipole radiators. We can plot the amplitude of the electric field as a function of direction around the antenna.

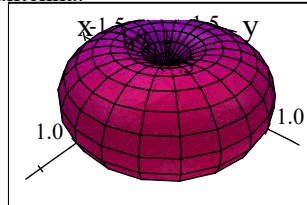

Angular dependence of  $S$  for a dipole scatterer.

We see that along the antenna axis, the field amplitude is zero. This means that the wave really does not go that direction. So in our case, the amount of polarization in the parallel direction decreases with the angle between the reflected and refracted rays until at  $90^\circ$  there is no reflected ray in the parallel direction.

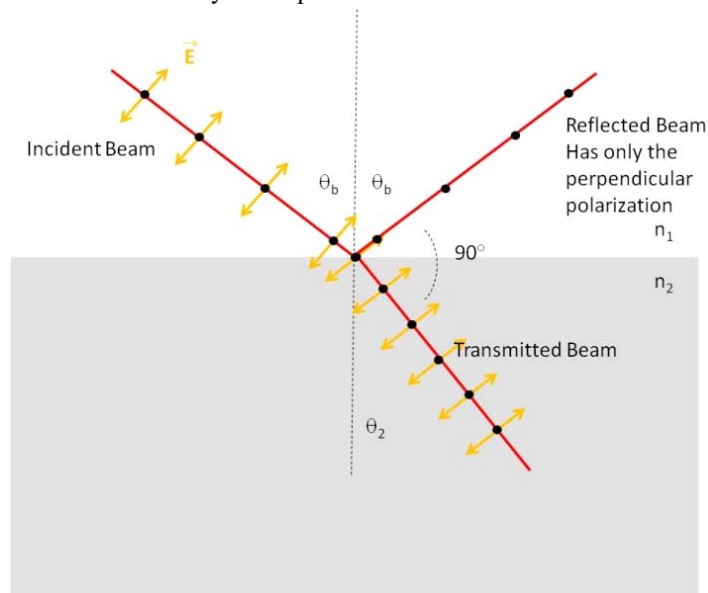

The incidence angle that creates an angular difference between the refracted and reflected rays of  $90^\circ$  is called the Brewster's *angle* after its discoverer. At this angle the reflected beam will be completely linearly polarized.

We can predict this angle. Remember Snell's law.

$$n_1 \sin \theta_1 = n_2 \sin \theta_2$$

Let's reliable the incidence angle  $\theta_1 = \theta_b$ . We take  $n_1 = 1$  and  $n_2 = n$  so

$$n = \frac{\sin \theta_b}{\sin \theta_2}$$

Now notice that for Brewster's angle, we have

$$\theta_b + 90^\circ + \theta_2 = 180^\circ$$

so

$$\theta_2 = 90^\circ - \theta_b$$

so we have

$$n = \frac{\sin \theta_b}{\sin (90^\circ - \theta_b)}$$

ah, but we remember that  $\sin (90^\circ - \theta) = \cos (\theta)$  so

$$n = \frac{\sin \theta_b}{\cos \theta_b}$$

but again we remember that

$$\tan \theta = \frac{\sin \theta}{\cos \theta}$$

so

$$n = \tan \theta_b \tag{34.2}$$

which we can solve for  $\theta_b$ .

$$\theta_b = \tan^{-1}(n)$$

This phenomena is why we wear polarizing sunglasses to reduce glare.

## Birefringence

Glass is an amorphous solid—that is—it has no crystal structure to speak of. But some minerals do have definite order. Sometimes the difference in the crystal structure creates a difference in the speed of propagation of light in the crystal. This is not to hard to believe. We said before that the reason light slows down in a substance is because it encounters atoms which absorb and re-emit the light. If there are more atoms in one direction than another in a crystal, it makes sense that there could be a different speed in each direction.

Calcite crystals exhibit this phenomena. We can describe what happens by defining two polarizations. One parallel to the plane of the figure below, and one perpendicular.



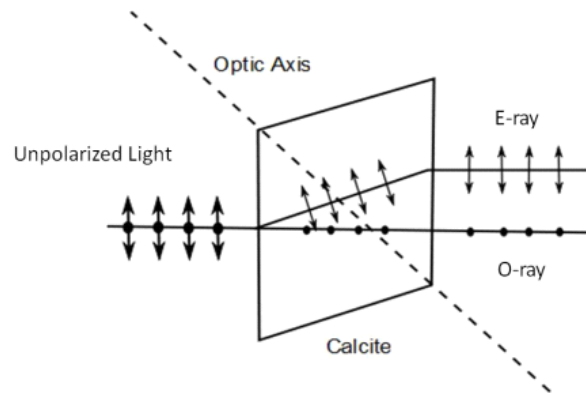

With a careful setup, we can arrange things so the perpendicular ray is propagated just as we would expect for glass. We call this the *O-ray* (for *ordinary*). The second ray is polarized parallel to the incidence plane. It will have a different speed, and therefore a different index of refraction. We call it the *Extraordinary ray* or *E-ray*.

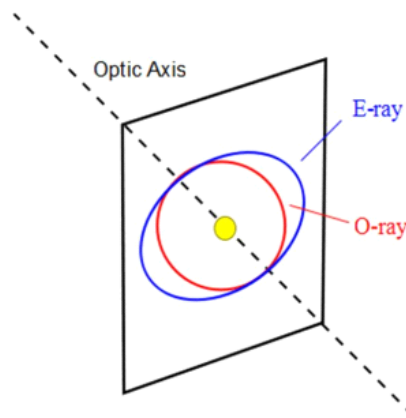

If we were to put a light source in a calcite crystal, we would see the *O-ray* send out a sphere of light as shown in the figure above. But the *E-ray* would send out an ellipse. The speed for the *E-ray* depends on orientation. There is one direction where the speeds are equal. This direction is called the *optic axis* of the crystal.



If our light entering our calcite crystal is unpolarized, then we will have two images leaving the other side that are slightly offset because the  $O$ -rays and  $E$ -rays both form images.

### Optical Stress Analysis

Some materials (notably plastics) become birefringent under stress. A plastic or other stress birefringent material is molded in the form planned for a building or other object (usually made to scale). The model is placed under a stress, and the system is placed between two polaroids. When unstressed, no light is seen, but under stress, the model changes the polarization state of the light, and bands of light are seen.

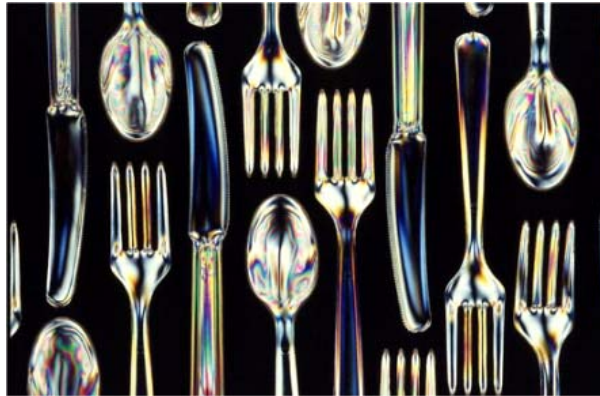

### Polarization due to scattering

It is important to understand that light is also polarized by scattering. It really takes a bit of electromagnetic theory to describe this. So for a moment, let's just comment that blue light is scattered more than red light. In fact, the relative intensity of scattered light goes like  $1/\lambda^4$ . This has nothing to do with polarization, but it is nice to know.

Now suppose we have long pieces of wire in the air, say, a few microns long. The pieces of wire would have electrons that could be driven into SHM when light hits them. If the wires were all oriented in a common direction, we would expect light to be absorbed if it was polarized in the long direction of the particles and not absorbed in a direction perpendicular to the orientation of the particles. This is exactly what happens when long ice particles in the atmosphere orient in the wind (think of the moment of inertia).

We often get impressive halo's around the sun due to scattering from ice particles.

Rain drops also have a preferential scattering direction because they are shaped like oblate spheroids (not "rain drop shape" like we were told in grade school).

It is also true that small molecules will act like tiny antennas and will scatter light preferentially in some directions and not in others. This is called *Rayleigh scattering* and is very like small dipole antennas.

## Optical Activity

Some substances will rotate the polarization of a beam of light. This is called being *optically active*. The polarization state of the light exiting the material depends on the length of the path through the material. Your calculator display works this way. An electric field changes the optical activity of the liquid crystal. There are polarizers over the liquid crystal, so sometimes light passes through the display and sometimes it is black.

## Laser polarization

One last comment. Lasers are usually polarized. This is because the laser light is generated in a *cavity* created by two mirrors. The mirror is tipped so light approaches it at the Brewster angle. Light with the right polarization (parallel to the plane of the drawing) is reflected back nearly completely, but light with the opposite polarization is not reflected at all. This reduces the usual loss in reflection from a mirror, because in one polarization the light must be reflected completely.

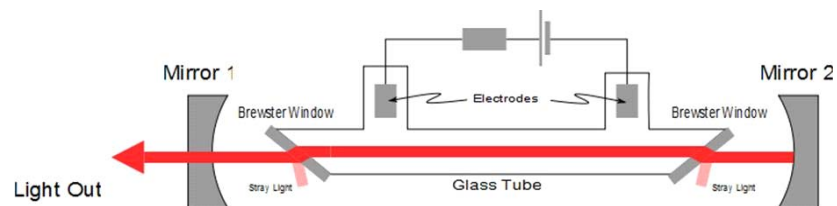

## Making alternating current

A few lectures ago, we studied the generator. But we found that a basic generator, we got a sinusoidal potential difference

$$\Delta V(t) = \Delta V_{\max} \cos(\omega t) \quad (34.3)$$

This sinusoidal potential will cause a sinusoidal current!

$$i(t) = I_{\max} \cos(\omega t) \quad (34.4)$$

Note that this  $\omega$  is just like the  $\omega$  from our oscillating RLC circuit. It is an angular frequency.

$$f = \frac{\omega}{2\pi} \quad (34.5)$$

Question 220.35.1

This alternating voltage is really not like a battery, so we need a new symbol for a source of alternating potential. We use a circle with a squiggle in it



We also need a way to write a current or potential that varies. It is traditional to use small letters to symbolize instantaneous values. We will do this, and we will explicitly write the dependence on  $t$ . So

$$\Delta v(t) = \Delta V_{\max} \cos(\omega t) \quad (34.6)$$

is the instantaneous electric potential from our alternating potential source. We can plot the current and the potential difference to compare them.

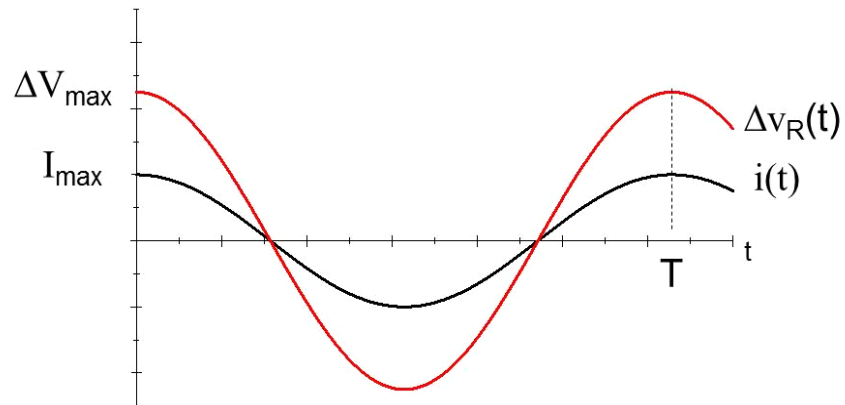

Notice that they have different amplitudes, but they are in phase (remember that phase tells us when they rise and fall, relative to each other). Thinking of Ohm's law, we would

expect the two curves to be proportional to each other. But we should be cautious. The current and voltage both change in time. So we can't just write

$$\Delta V = IR$$

we need to specify which  $\Delta V$  and which  $I$  since each constantly change. We will investigate a solution to this problem in our next lecture.



# 35 Alternating Currents and Potentials

Question 220.35.1

Question 220.35.2

Question 220.35.3

We found in our last lecture that Ohm's law might need some modification for circuits with alternating emfs. We will find a convenient way to solve this problem in this lecture. We will also set the groundwork for dealing with more complicated circuit elements that change the relative phase between the current and electric potential.

## Fundamental Concepts

- We use *rms* values for the current and potential for alternating currents
- We use phasor diagrams to describe the relative between the current and electric potential

## Instantaneous current and potential

To introduce alternating potentials, let's take a simple circuit as shown.

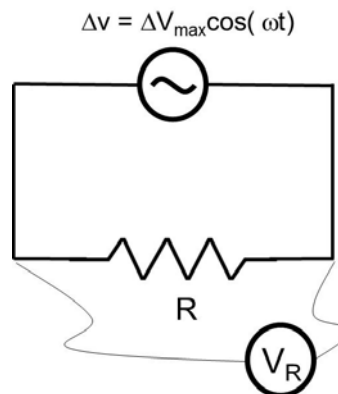

Kirchhoff's rule applies here (no mysterious B-fields). But now our currents and potential differences are time dependent. So Kirchhoff's rules must apply for each

instant of time. Let's review Kirchhoff's rules. Recall that

$$\Delta V = -\oint \mathbf{E} \cdot d\mathbf{s} = L \frac{dI}{dt}$$

The loop rule says that if we add up all the changes in electric potential we get (assuming the inductance,  $L$ , is small enough that we can ignore it)

$$\oint \mathbf{E} \cdot d\mathbf{s} \approx 0 \quad (35.1)$$

And this is just

$$\sum \Delta V \approx 0$$

We find for our simple circuit that

$$\Delta v(t) + \Delta v_R(t) = 0 \quad (35.2)$$

note that these are instantaneous values. We recall that for the *emf*

$$\Delta v(t) = \Delta V_{\max} \cos(\omega t)$$

So, the magnitude of  $\Delta v_R$  is also

$$\Delta v_R = \Delta V_{\max} \cos(\omega t)$$

Now, using these instantaneous values, we can use Ohm's law

$$\Delta v(t) = i(t) R$$

where  $i$  is the instantaneous current.

$$\begin{aligned} i(t) &= \frac{\Delta v_R(t)}{R} \\ &= \frac{\Delta V_{\max}}{R} \cos(\omega t) \end{aligned} \quad (35.3)$$

we recognize  $\Delta V_{\max}/R$  as a current, the maximum current.

$$i(t) = I_{\max} \cos(\omega t) \quad (35.4)$$

Question 220.35.4

This gives us an idea. If we use the maximum value for the potential and current, then we can just use Ohm's law.

$$\Delta V_{\max} = I_{\max} R \quad (35.5)$$

Question 220.35.5

Now this *does* work, but we should realize that the current is not at its maximum value for most of the time. We will want to choose a more representative value. Note that this cannot be the average current, that is zero! We choose to take the average of the square of the current and square root it. You may already know this process! It is taking the *rms* of the current.

Question 220.35.6

Let's see how it works. If I take the average of a sine function I get zero because it spends as much time below the axis as above

$$\sin(x)$$



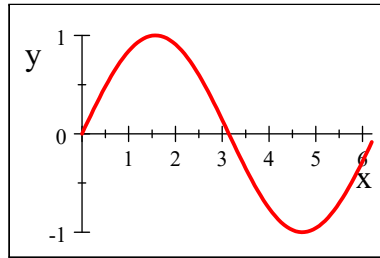

but the square of a sine function is always positive.

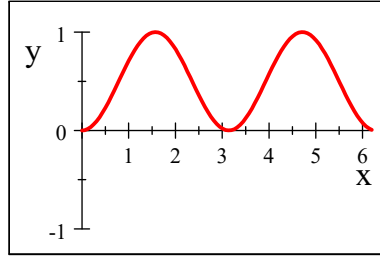

it is kind of believable that the average of this sine squared function would be 1/2

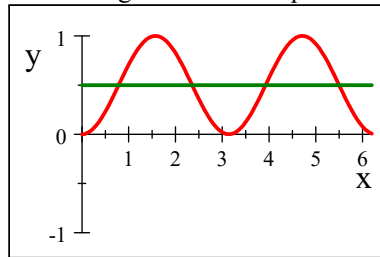

Then our average value of the current squared is

$$\frac{1}{2} I_{\max}^2 \tag{35.6}$$

Question 220.35.7

We said we would take the square root of the average of the square of the current. We just convinced ourselves that the average of the square of the current is 1/2 its original value because the average of the square of the sine function is 1/2. So all we have to do now is take a square root.

$$I_{rms} = \sqrt{\frac{1}{2} I_{\max}^2} = \frac{I_{\max}}{\sqrt{2}} \tag{35.7}$$

We can do the same thing for the potential

$$\Delta V_{rms} = \frac{\Delta V_{\max}}{\sqrt{2}} \tag{35.8}$$

and the *rms* current and potential difference will obey Ohm's laws and all our former equations.

$$\Delta V_{rms} = I_{rms} R \tag{35.9}$$

Question 220.35.8

Question 220.35.9

Question 220.35.10

**Power dissipated**

For example, we used to say that

$$\mathcal{P} = I^2 R \quad (35.10)$$

now that is not true for alternating currents, but we can say

$$\mathcal{P}_{ave} = I_{rms}^2 R \quad (35.11)$$

Note that this makes sense. The resistor does not care which direction the current flows ( $I$  is squared in the power equation), but it does care that there is less current than if we had a steady flow at  $I_{max}$ .

**Phasor Addition**

Question 220.35.11

Let's return to our graph of the instantaneous current and potential. We can use the connection we made in PH123 (or will make now) between circular motion and oscillatory (sinusoidal) motion. Let's take a generic set of variables,  $x$  and  $y$ . Then

$$\tan \theta = \frac{x}{y} \quad (35.12)$$

$$\cos \theta = \frac{x}{h} \quad (35.13)$$

$$\sin \theta = \frac{y}{h} \quad (35.14)$$

Let's relate these trig functions to their projections onto the axis

Question 220.35.12 The projection of circular motion onto the  $x$ -axis gives simple harmonic motion. Look at the projection  $x$  of the point  $P$  on the  $x$  axis. Lets follow this projection as  $P$  travels around the circle. We find it ranges from  $-x_{\max}$  to  $x_{\max}$ . If we watch closely we how  $x(t)$  varies as a function of time, we find that it's rate of change with respect to time is zero at the extreme points and is a maximum in the middle. This projection is given as the cosine of the vector from the origin to  $P$ .

$$x(t) = x_{\max} \cos \theta \quad (35.15)$$

Question 220.35.13 This model, indeed fits our description of our instantaneous potential if we have  $\theta = \omega t$  as the time dependence of  $\theta$ .

A phasor is a representation of our time varying quantity as a vector projection on an axis (the  $y$ -axis in this case) of a vector that rotates around the axis with angular velocity equal to the angular frequency.

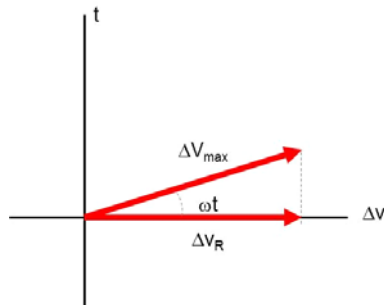

Question 220.35.14 As the large vector of length  $\Delta V_{\max}$  rotates, the projection moves from it's maximum at  $\omega t = 0 \text{ rad}$  and is zero at  $\omega t = \pm \pi/2$ .

Question 220.35.15

Question 220.35.16

We can draw a similar phasor diagram for the current

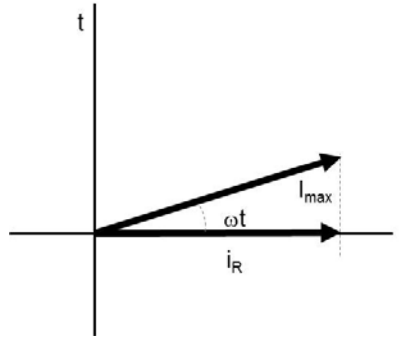

If we share  $y$ -axes, we will note that the two phasors ( $\Delta v$ , and  $i$  phasors) rotate together. they are *in phase*.

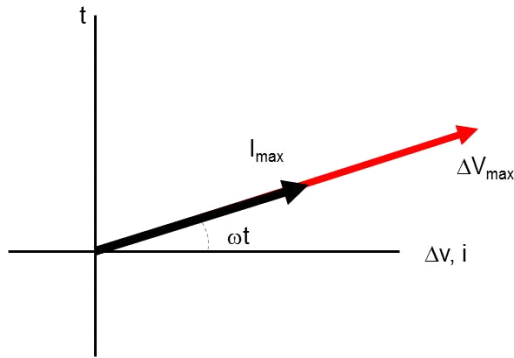

Question 220.35.16

Note that the magnitudes are not the same, and there is no reason we would expect them to be. They are different quantities.

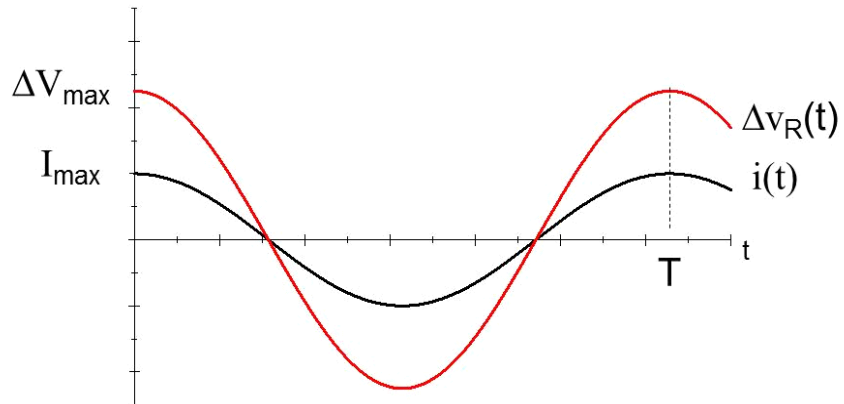

But we see that the phasors traveling together means that the voltage and the current rise and fall at the same time. This is what being *in phase* means.

Of course, all this assumed that

$$\oint \mathbf{E} \cdot d\mathbf{s} \approx 0$$

but what if the inductance is not small enough that we can ignore it?

$$\oint \mathbf{E} \cdot d\mathbf{s} = -L \frac{dI}{dt}$$

We will find that if we have a circuit element that slows the current, the potential and current may be out of phase. We will take this problem up next lecture.



# 36 AC circuits with Capacitors and Resistors

## Fundamental Concepts

- In AC RC circuits, the capacitor voltage lags the current with a phase difference of  $\pi/2$
- Reactance is like resistance in AC circuits
- The capacitive reactance is given by  $X_C = \frac{1}{\omega C}$

## AC Circuits and Capacitors

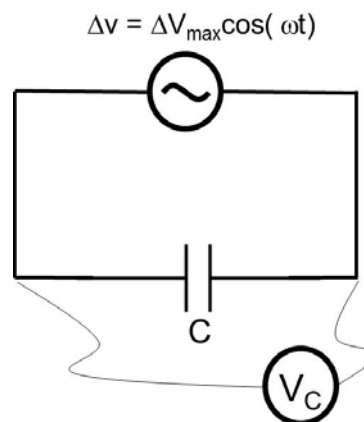

Now let's consider what an AC circuit will do to a capacitor. Recall that a capacitor will, after a time, stop a direct current. Recall that the reason for this is that as charge builds up on the capacitor, new charges coming to the capacitor are repelled by the charges already on the capacitor plates. The charges on the plates form an electric field in the capacitor, so there is an electric potential across the plates in the capacitor.

This electric potential grows with more charge (think of our water tank analogy). The building potential difference across the capacitor opposes the flow of more charge to the capacitor. Eventually the current just stops.

But now we have a potential due to our alternating emf that changes. Charge starts to build on the capacitor, but then the emf potential switches. This makes charge rush away from the capacitor. Again the potential switches at the emf. So again the charge rushes to the capacitor. Current flows through the whole circuit and never stops because we keep switching the direction of the emf. Notice how different this is from a battery-capacitor circuit. Eventually the current stops for the battery circuit. But for our alternating emf, we really don't stop an alternating current with a capacitor!

But the building and unbuilding of a potential difference in the capacitor does slow the current some. If we plot the capacitor potential,  $v_C(t)$  and current,  $i(t)$ , we get a graph that looks like this

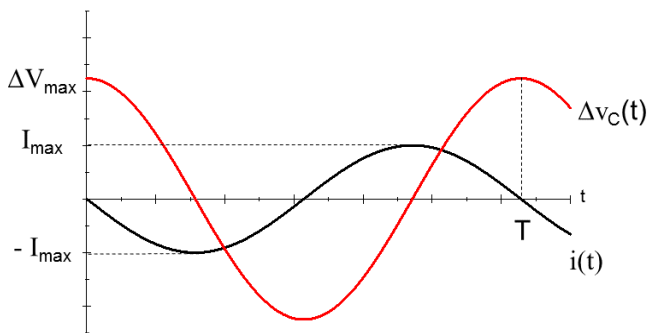

Let's analyze this graph starting when the potential across the capacitor is maximum. The capacitor is fully charged. So at this split instant of time no current will flow.

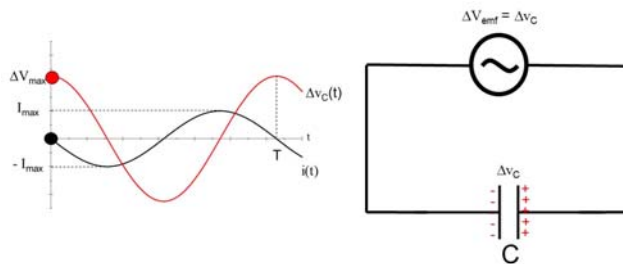

But then the source emf voltage starts to decrease. So charge will flow from the higher capacitor potential back to the emf source because the source now has a lower potential.



In the graph you see that as we move from  $t = 0$  the capacitor voltage decreases and the current increases, but it increases negatively.

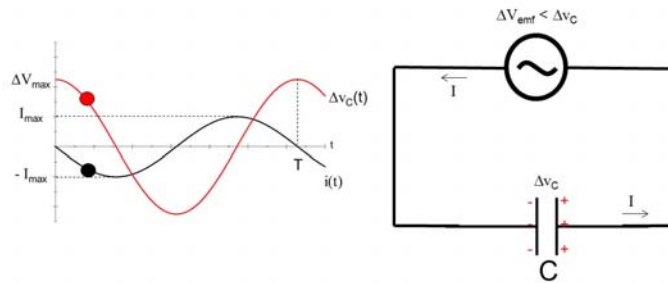

The charge is going toward the emf source.

At some point the capacitor is completely drained. So it has a potential of zero volts.

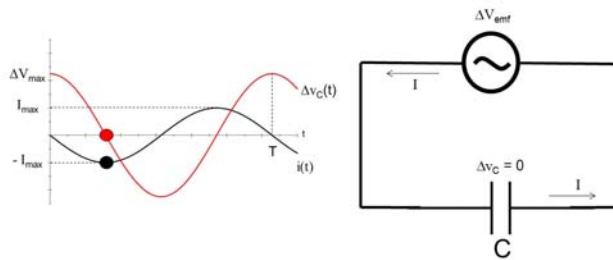

But by now the source emf has totally reversed direction and is increasing in magnitude. So charge will rush from the higher potential in the emf source to the capacitor.

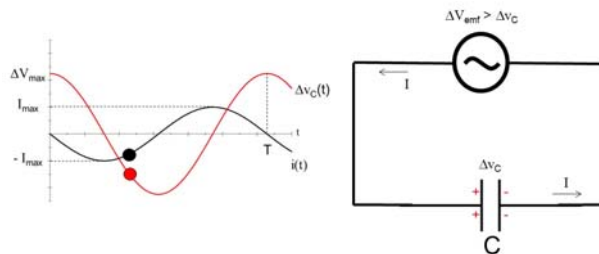

And we will fill the capacitor the opposite way we had it before. Where the negative charge was, we will fill with positive charge and vice versa. At some point, the capacitor will be full again

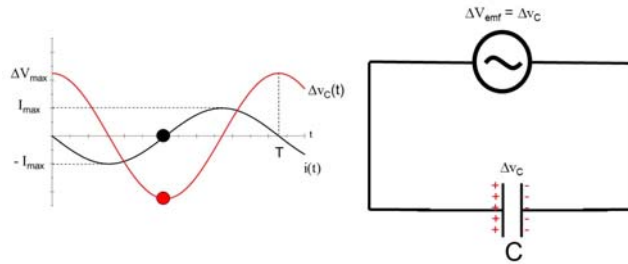

and the current will stop for an instant. This is when the capacitor potential is once again equal to the source emf. But at this point the source emf again loses potential and current begins to flow, but this time the other direction.

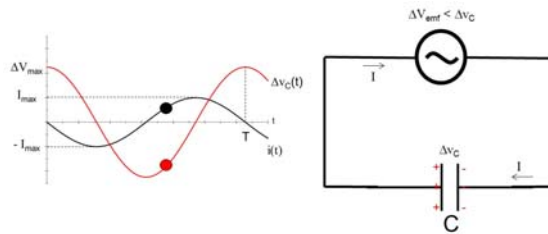

This process just keeps repeating itself.

Note that really what we are seeing is normal behavior for an  $RC$  circuit. It takes time for a capacitor to charge or discharge in an  $RC$  circuit. And that is what is happening here. Let's apply our equations for the alternating potential for this situation. The capacitor instantaneous potential will be

$$\Delta v_C(t) = \Delta V_{\max} \cos \omega t \tag{36.1}$$

and we know from our study of capacitors

$$q = C \Delta v_C \tag{36.2}$$

so

$$q(t) = C \Delta V_{\max} \cos \omega t \tag{36.3}$$

Of course we take a derivative to find the current

$$i(t) = \frac{dq(t)}{dt} = -C \Delta V_{\max} \omega \sin \omega t \tag{36.4}$$

It is traditional to rewrite this as

$$i(t) = -\omega C \Delta V_{\max} \cos \left( \omega t + \frac{\pi}{2} \right) \tag{36.5}$$

$$= I_{\max} \cos \left( \omega t + \frac{\pi}{2} \right) \tag{36.6}$$

If you have taken PH123 you immediately notice that the current, and the potential difference across the capacitor are out of phase. Remember that this means that they are both cosine functions, but one starts later than the other. Since the shift is a positive

$+\pi/2$ , the current is shifted to the left, and that means that current is the one that starts earlier.

And that is just what our analysis of the circuit has found. The cosine function for the current seems to start earlier than the cosine function for potential (it is already a quarter of a cycle ahead when our graph starts!). If these two cosine functions were angular measures, they would have a phase difference of  $90^\circ$ . So we say that they are  $90^\circ$  out of phase. We can use our idea of phasors to draw this situation.

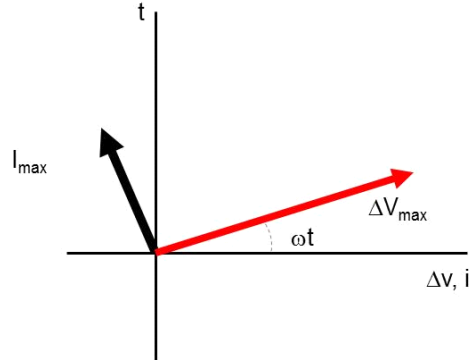

---

The voltage across a capacitor always lags the current by  $90^\circ$  for AC currents.

---

Since the capacitor is slowing the current, we can say that it acts much like a resistor for alternating currents. In fact, let's consider how the capacitor slows the current. First, we can guess that as the capacitance gets larger it takes longer to fill the capacitor, so there is less charge build up for a given cycle, and therefore less potential difference in the capacitor. It is the potential difference that slows down or *impedes* the current, so we can see that our new resistance-like-effect should be inversely proportional to the capacitance. Let's give this new resistance to alternating current the symbol  $X_C$ , so we can write

$$X_C \propto \frac{1}{C} \quad (36.7)$$

We can also reason that the faster the potential swaps happen at the source, the less the charge build-up will happen on the capacitor, so there will be less potential to slow the current. Then the resistance like property of the capacitor should be inversely proportional to the frequency of the alternating voltage source

$$X_C \propto \frac{1}{f} \quad (36.8)$$

We usually combine these two effects into one equation for  $X_C$

$$X_C = \frac{1}{2\pi fC} = \frac{1}{\omega C} \quad (36.9)$$

The name given to this resistance like quantity,  $X_C$ , is the *capacitive reactance*.

The wonderful thing about this new quantity is that it obeys Ohm's law like a resistance!

$$\Delta V_{C,rms} = I_{rms} X_C \quad (36.10)$$

well, OK we had to use the *rms* value of  $\Delta V$  and  $I$ , but that is what our voltmeters and ammeters read for AC currents! so it is great that it works out so simply!

## Rectifiers and Filters

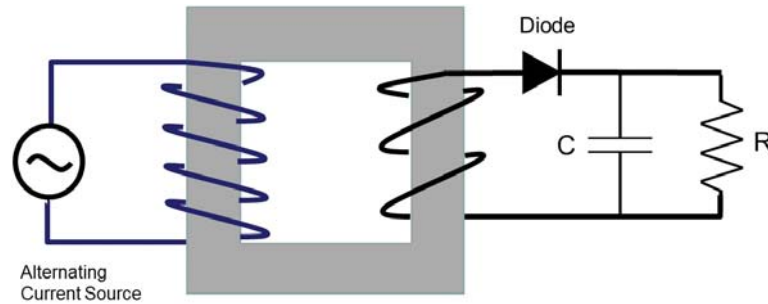



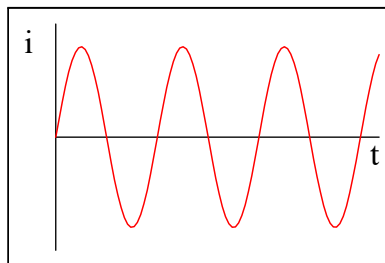

We mentioned in class that you would not want to plug your iPad into the “dirty” current provided by a standard generator. Our generator design in the book is even worse. Remember we had alternating current like this

$$i(t) = I_{\max} \sin(\omega t) \quad (36.11)$$

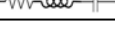

but our iPad can't handle alternating current, so we need to remove the negative current. We can do this with a diode (a device that has a high resistance when current flows one way, and a low resistance when current flows the other way). Then our current would look something like this

Circuit Elements	Impedance (Z)	Phase Angle (φ)
	$R$	0
	$X_C$	$-\frac{\pi}{2}$
	$X_L$	$\frac{\pi}{2}$
	$\sqrt{R^2 + X_C^2}$	$-\frac{\pi}{2} < \phi < 0$
	$\sqrt{R^2 + X_L^2}$	$0 < \phi < \frac{\pi}{2}$
	$\sqrt{R^2 + (X_L^2 - X_C^2)}$	Negative if $X_C > X_L$ Positive if $X_C < X_L$

Usually for our iPad we have a transformer involved, so we place the diode on the iPad side of the transformer.

Our iPad is not happy though. Half the time it is getting no current at all! So we add in a resistor and a capacitor as shown in the next figure

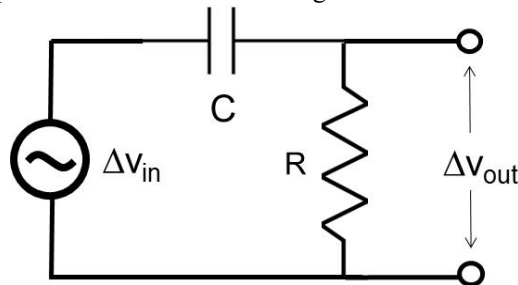

Now we know what happens when we plug this in. The capacitor charges when the current starts to flow. But the current from the transformer and diode will reach a peak and start to fall off. When this happens, the capacitive circuit will start to discharge, making the current drop much more slowly that it did on the wall side of the transformer. We get something like this where the heavy (green) curve is the resulting current.

This current is much better, but still not great for audio systems. You would hear an annoying hum on top of your beautiful Mormon Tabernacle Choir music. A good audio system will have additional filter circuits to remove the "ripple" in the current that remains from our power plug. But we have described what is usually in the little box that you plug into the wall to power your electronics. The additional filtering is often in the device.

Figure 36.9.

We have learned that the capacitive reactance depends on the frequency of the oscillation. If the frequency was very small, we would still get to zero current in between current peaks. If the frequency is very large, then there would be barely any time for decay, so the ripple would be small. This implies that we can change the filter effect on AC if we change the frequency. Alternately, we can leave the frequency at 60 Hz and change the capacitor to get different response. We can pick out which frequencies are left in the ripple.

Take for example this circuit

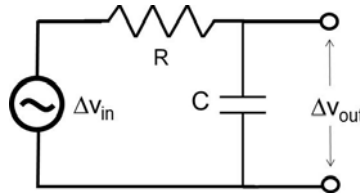

We would expect current to flow in the circuit, and the resistance,  $R$ , will slow that flow. The capacitor will also slow this flow because it has a capacitive reactance. The combined effect would be a little like having two resistors in series, but where one resistor's resistance depends on the frequency of the alternating current.

Recall that if we have two resistances in series each has a voltage drop of  $IR$ .

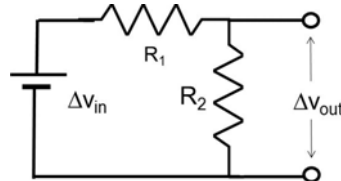

The two resistor voltage drops must equal the source voltage

$$\Delta V_{bat} = IR_1 + IR_2$$

and we can see that if we lower the resistance of  $R_1$  then the voltage across  $R_2$  will be larger.

Since  $X_C = 1/(\omega C)$  the reactance goes down as the frequency increases. So as we measure the voltage across the capacitor, it is like the resistance is lower for the capacitor at higher frequencies. The voltage across the capacitor is

$$\Delta V_c = I_C X_C$$

so as  $X_C$  goes down, so does the voltage. We have a higher voltage for lower frequencies and a lower voltage for higher frequencies.

We can plot the voltage that leaves the circuit divided by the voltage that we input into the circuit as a function of the frequency of the input AC. We see that low frequencies get through the circuit just fine, but large frequencies don't get through.

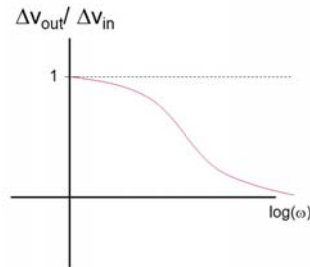

The capacitive circuit is not able to discharge and charge fast enough to keep up.

Here is another circuit

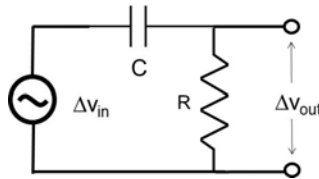

Note that we have switched the capacitor and resistor positions. It is still like a series circuit with a reactance and a resistance. But now the reactance comes first and we are measuring the voltage across the resistor. As the frequency increases,  $X_C$  decreases, so  $\Delta V_R$  will get larger.

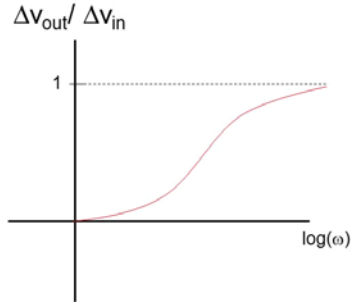

Since we are measuring  $\Delta V_R$  as our output, then we get a larger voltage for higher frequencies. Thus, the circuit passes all the high frequencies (like those high notes from the sisters in the MoTab) but removes low frequencies (like our 60 Hz hum).

Filter design can be very complicated. Notch filters pass a narrow band of frequencies. Electrical engineers usually have course work in filter design. Now days filtering is often done digitally by transforming the signal into the Fourier domain, removing unwanted frequencies, and inverse transforming back to the signal domain. This is great when you can, but if you want to remove the annoying interference from the local business's radio signals, a good hardware filter on your TV input is a wonderful thing.

This is something to think about as you design experiments. What electronic noise may exist. What filter is built into your test equipment. You may want to add a filter to eliminate the noise. Conversely, you may find that your equipment's filter has removed the signal you wanted!



# 37 Inductive AC Circuits, and the LRC AC circuit

So far we have allowed resistors and capacitors in our AC circuits. It is time to include inductors.

## Fundamental Concepts

- The inductive reactance  $X_L = 2\pi fL = \omega L$

## AC Circuits and Inductors

Question 220.37.1

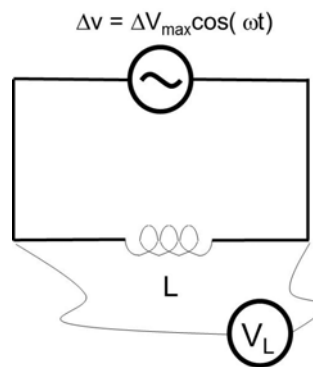

When we learned about inductors a few lectures ago, we found that we can pretend that there is an emf induced in the inductor

$$\mathcal{E}_L = -L \frac{\Delta I}{\Delta t} \quad (37.1)$$

really there is an amount of energy tied up in making the magnetic field in the inductor. But in this lecture, we will treat this just as though it were a normal voltage.

We do need to rewrite this to match our AC notation

$$\Delta v_L(t) = -L \frac{\Delta i(t)}{\Delta t} \quad (37.2)$$

to show time dependence. And we can use Kirchhoff's rules to find the current and voltage as a function of time. Because of the inductor, this is a little more difficult than the purely conductive circuit. But in going around the loop we still have

$$\Delta v(t) + \Delta v_L(t) = 0$$

and we can write out  $\Delta v_L(t)$  so that

$$\Delta v(t) - L \frac{di(t)}{dt} = 0 \quad (37.3)$$

Using our equation for  $\Delta v(t)$ , we see that

$$\Delta V_{\max} \cos(\omega t) = L \frac{di(t)}{dt} \quad (37.4)$$

this tells us that

$$\frac{\Delta V_{\max}}{L} \cos(\omega t) dt = di(t) \quad (37.5)$$

and of course we can integrate both sides of the equation

$$\int_0^t \frac{\Delta V_{\max}}{L} \cos(\omega t) dt = \int_0^I di \quad (37.6)$$

The right hand side is just  $I$ . So that

$$I = \frac{\Delta V_{\max}}{L} \int_0^t \cos(\omega t) dt = \frac{\Delta V_{\max}}{\omega L} \sin \omega t \quad (37.7)$$

Again we will write this in terms of the cosine function so we can compare our inductive circuit current to the resistive and capacitive circuit currents.

$$I = \frac{\Delta V_{\max}}{\omega L} \cos\left(\omega t - \frac{\pi}{2}\right) \quad (37.8)$$

Note again that the current has a phase constant, this time  $-\pi/2$ .

We should also remember that the induced emf will oppose the current, so it slows down the current (it is a back emf). We immediately think of our capacitive reactance and wonder if we can define an inductive reactance! And indeed we can

$$X_L = 2\pi f L = \omega L \quad (37.9)$$

Let's see if it makes sense. We expect the back emf to increase as  $L$  increases. This is like placing a small battery in the circuit backwards. It will slow the current. The back emf increases with  $L$ , so having the resistance-like property increase with  $L$  makes sense. Since the back emf goes like  $-L \frac{\Delta I}{\Delta t}$  we expect that the faster the current changes, the more resistance-like behavior we will get, so our reactance should increase with frequency. So this equation makes sense. Now we can write an AC version of Ohm's law for inductors

$$\Delta V_{L,rms} = I_{rms} X_L \quad (37.10)$$

and we can immediately see that

$$\Delta v_L = I_{\max} X_L \cos \omega t \tag{37.11}$$

which shows us the phase relationship between  $i(t)$  and  $\Delta v_L(t)$ . The phase difference of  $-\pi/2$  says that the current will now lag the voltage.

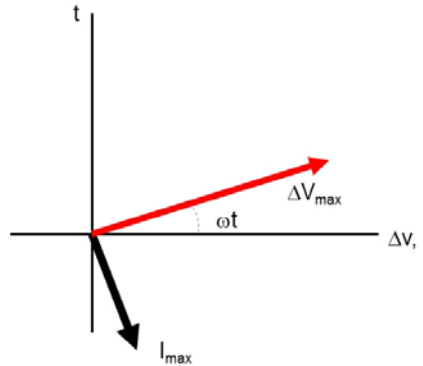

we can plot both  $i(t)$  and  $\Delta v_L(t)$  as a function of time.

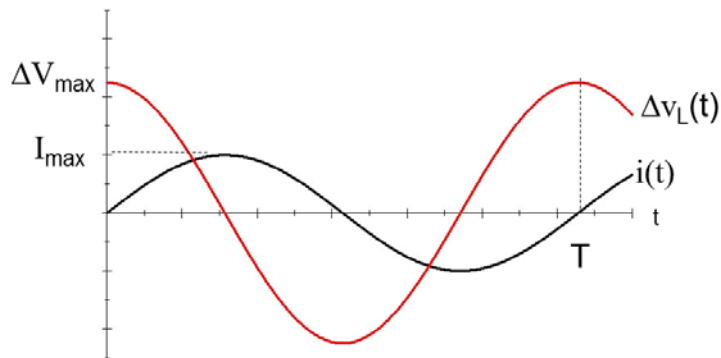

To see why the current and potential are out of phase, consider point right at  $t = 0$ . The potential of the inductor is largest when the change in  $I$  is largest. When the change is zero, we expect the potential to be zero.

---

For an inductor, the current lags the potential by  $90^\circ$  for AC currents

---

Question 220.37.3

### RLC Series circuits

Question 220.37.4

Question 220.37.5

Of course, we can have *both* capacitors *and* inductors in our circuits.

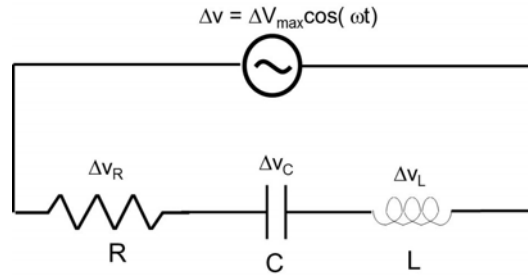

It is tempting to treat all these circuit elements as reactances, and just use our normal circuit theory to find the current or potential drops. We can almost do this. If they were all resistors we would just add the resistances

$$R_{eq} = R_1 + R_2 + R_3$$

but resistors do not alter the phase relationship between  $\Delta V$  and  $I$ . Capacitors and inductors do. So our alternating voltage drops won't all be low or high at the same time. So we need a clever trick to find the total reactance. This is where the idea of a phasor becomes useful. We can use our knowledge of vector addition, and treat the potential drops like vectors!

Let's start with  $i(t)$  and  $\Delta v(t)$  as a function of time.

$$\Delta v(t) = \Delta V_{\max} \cos(\omega t)$$

$$i(t) = I_{\max} \cos(\omega t + \phi)$$

where  $\phi$  is the phase constant. So far  $\phi$  has been  $\pm\pi/2$  or  $0$  depending on which circuit element we have.

Let's draw a phasor diagram for  $i(t)$  and  $\Delta v_R(t)$

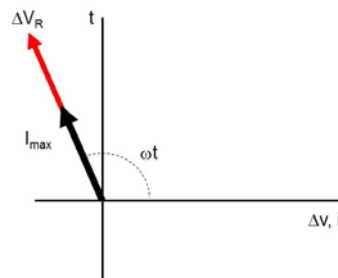

The  $\phi$  for a resistor is zero. For a capacitor it is  $+90^\circ$ . That is, the current leads the

voltage. We already know where the current is on our phasor diagram, It has to be in the same place for the whole circuit because we have a series circuit. Therefore, the current must be in the same spot on the phasor diagram for the capacitor as it is for the resistor. So now we need to draw the voltage  $90^\circ$  behind the current for the capacitor. It looks like this.

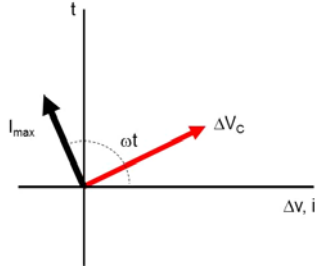

For our inductor,  $\phi = -90^\circ$ . The current must still be in the same place on the diagram. But this time the potential will be  $90^\circ$  ahead of the current. The phasor diagram looks like this:

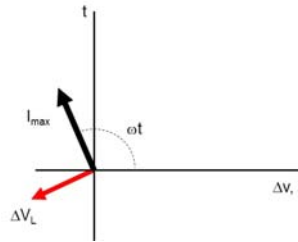

If we put all the phasors on the same diagram we get the following figure.

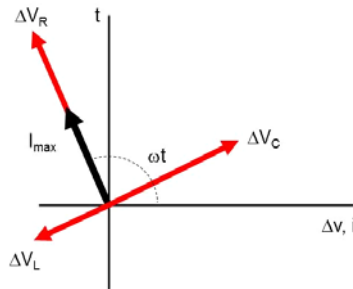

and this is for a particular  $\omega t$ . At some later time the figure would look like this

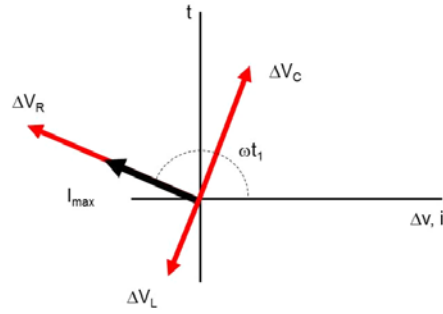

and at a still later time it would look like this

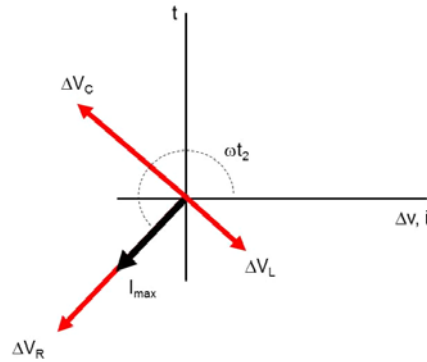

All the phasors circle at a rate  $\omega$  together. Let's look at our phasor diagram at a particular time,  $t = 0$  Then our figure would look like this

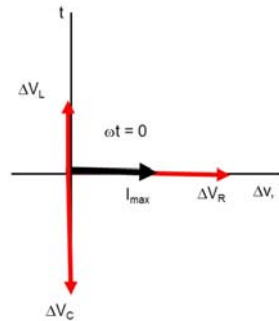

From this view, we can see how we might find the total reactance of the circuit. The phasors look just like vectors. We can find a resultant vector that would represent what you would get by adding all the potential phasors together as though they were vectors. We know that to add vectors we take components. In the  $y$ -direction we would get

$$\Delta v_y(t) = \Delta v_L - \Delta v_C$$

and in the  $x$ -direction we would have only

$$\Delta v_x = \Delta v_R$$

Then the magnitude of the potential would be

$$\begin{aligned} \Delta v_{\max} &= \sqrt{\Delta v_x^2 + \Delta v_y^2} \\ &= \sqrt{\Delta v_R^2 + (\Delta v - \Delta v_C)^2} \end{aligned}$$

The direction (in the phasor diagram) is given by

$$\psi = \tan^{-1} \left( \frac{\Delta v_y}{\Delta v_x} \right) \tag{37.12}$$

$$= \tan^{-1} \left( \frac{\Delta v_L - \Delta v_C}{\Delta v_R} \right) \tag{37.13}$$

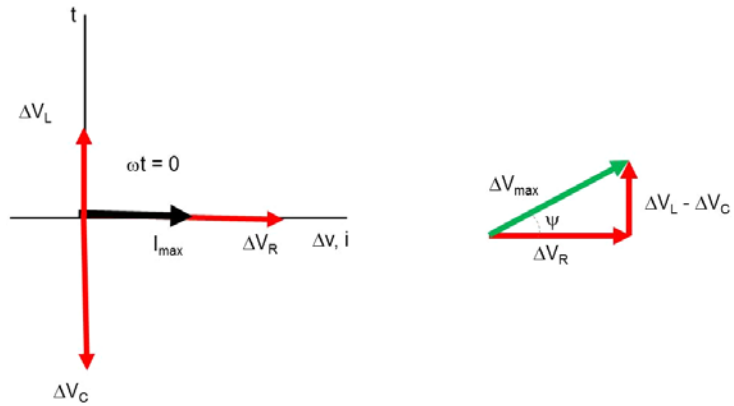

Note that in the figure we have  $\Delta v$  called  $\Delta v_{\max}$ . This is the length of our resultant phasor. Of course as the phasors rotate, the actual potential difference for the circuit will be

$$\Delta v(t) = \Delta v_{\max} \cdot \sin(\omega t + \psi)$$

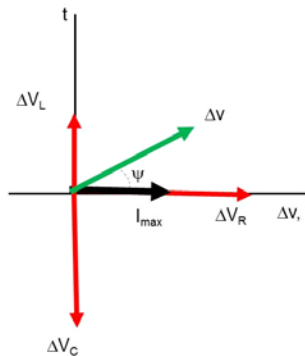

so at some later time,  $t$ , the potential drop could be less.

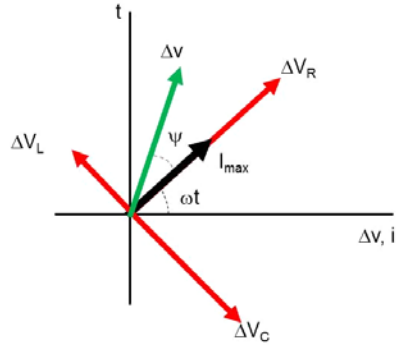

We would still like to use Ohm’s law for LRC circuits. We would need to give a symbol for the resistance like quantity due to the inductor, resistor, and capacitor. Let’s use  $Z$ . Then Ohm’s law would look like

$$\Delta V_{\max} = I_{\max}Z \tag{37.14}$$

where this  $Z$  is like the total resistance. We can do this by taking the magnitude of the resulting vector

$$\Delta v_{\max} = \sqrt{\Delta v_R^2 + (\Delta v_L - \Delta v_C)^2} \tag{37.15}$$

and using it in Ohm’s law

$$I_{\max}Z = \sqrt{\Delta v_R^2 + (\Delta v_L - \Delta v_C)^2} \tag{37.16}$$

We know that the same current must flow through the entire series circuit. So we can write this as

$$\begin{aligned} I_{\max}Z &= \sqrt{(I_{\max}R)^2 + (I_{\max}X_L - I_{\max}X_C)^2} \\ I_{\max}Z &= \sqrt{I_{\max}^2 \left( (R)^2 + (X_L - X_C)^2 \right)} \\ I_{\max}Z &= I_{\max} \sqrt{\left( (R)^2 + (X_L - X_C)^2 \right)} \\ Z &= \sqrt{(R)^2 + (X_L - X_C)^2} \end{aligned}$$

so we can “add” all the reactances together! It is just a little bit harder than adding numbers! Since this is the magnitude of the combined reactance we should also worry



about a phase.





$$\psi = \tan^{-1} \left( \frac{\Delta v_L - \Delta v_C}{\Delta v_R} \right) \tag{37.17}$$

$$= \tan^{-1} \left( \frac{I_{\max} X_L - I_{\max} X_C}{I_{\max} R} \right) \tag{37.18}$$

$$= \tan^{-1} \left( \frac{X_L - X_C}{R} \right) \tag{37.19}$$

and we see that the phase is just the same as the phase of the potential.

We call this combined reactance the *impedance*, because it impedes or opposes the AC current. Now suppose we don't have all three types of circuit elements, can we describe an impedance? Sure! The following figure gives the circuit elements present in a series circuit, their impedance, and the phase.

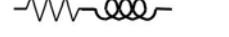
Circuit Elements	Impedance (Z)	Phase Angle ( $\psi$ )
	$R$	0
	$X_C$	$-\frac{\pi}{2}$
	$X_L$	$\frac{\pi}{2}$
	$\sqrt{R^2 + X_C^2}$	$-\frac{\pi}{2} < \psi < 0$
	$\sqrt{R^2 + X_L^2}$	$0 < \psi < \frac{\pi}{2}$
	$\sqrt{R^2 + (X_L^2 - X_C^2)}$	Negative if $X_C > X_L$ Positive if $X_C < X_L$

### Resonance and LRC circuits again

Remember that when a driven harmonic oscillator was driven at the natural frequency we had resonance. Let's look at the current of our *RLC* circuit. It has an equation very like a harmonic oscillator. The current is given by

$$I_{rms} = \frac{\Delta V_{rms}}{Z} \tag{37.20}$$

or

$$I_{rms} = \frac{\Delta V_{rms}}{\sqrt{(R)^2 + (X_L - X_C)^2}} \tag{37.21}$$

When  $X_L = X_C$  this will be a maximum. This is a form of resonance. Starting with

$X_L = X_C$ , we can find the frequency that will be the resonant frequency.

$$\begin{aligned} X_L &= X_C \\ 2\pi fL &= \frac{1}{2\pi fC} \end{aligned}$$

then

$$f^2 = \frac{1}{4\pi^2 LC}$$

or

$$\begin{aligned} f &= \sqrt{\frac{1}{4\pi^2 LC}} \\ &= \frac{1}{2\pi\sqrt{LC}} \end{aligned} \quad (37.22)$$

Why do we care? This is a tuning circuit used in radios! We can include a variable capacitor or a variable inductor in the circuit, and make it resonate with a desired frequency. Usually a variable capacitor is used. So when you turn the dial on your radio to adjust the frequency, you are changing the capacitance of a variable capacitor!

first we write the current as

$$I_{rms} = \frac{\Delta V_{rms}}{\sqrt{(R)^2 + (X_L - X_C)^2}} \quad (37.23)$$

$$\begin{aligned} &= \frac{\Delta V_{rms}}{\sqrt{(R)^2 + (\omega L - \frac{1}{\omega C})^2}} \\ &= \frac{\Delta V_{rms}}{\sqrt{(R)^2 + L^2 (\omega - \frac{1}{\omega LC})^2}} \end{aligned} \quad (37.24)$$

$$= \frac{\Delta V_{rms}}{\sqrt{(R)^2 + \frac{L^2}{\omega^2} (\omega^2 - \frac{1}{LC})^2}} \quad (37.25)$$

and remember that

$$\omega_o = \frac{1}{\sqrt{LC}} \quad (37.26)$$

is the natural frequency of oscillation for a RLC circuit. so

$$I_{rms} = \frac{\Delta V_{rms}}{\sqrt{(R)^2 + \frac{L^2}{\omega^2} (\omega^2 - \omega_o^2)^2}} \quad (37.27)$$

Let's plot this for a few values

$$\begin{aligned} L &= 50 \times 10^{-6} \text{ H} \\ C &= 2.0 \times 10^{-9} \text{ F} \\ \Delta V_{rms} &= 5 \times 10^{-3} \text{ V} \\ \omega_o &= 1 \times 10^7 \frac{\text{rad}}{\text{s}} \end{aligned}$$

$$I_{rms} = \frac{5 \times 10^{-3}}{\sqrt{(R)^2 + \frac{(50 \times 10^{-6})^2}{\omega^2} (\omega^2 - (1 \times 10^7)^2)^2}}$$

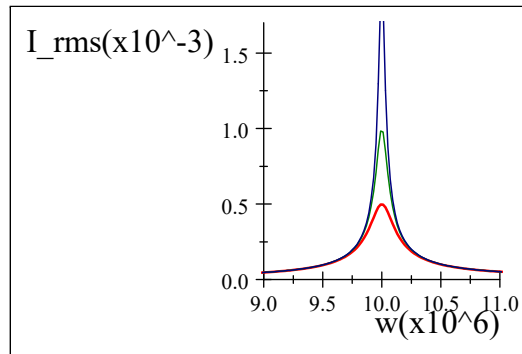

I have included plots for three different resistances,  $R = 10 \Omega$ ,  $5 \Omega$ , and  $2.5 \Omega$ .

## Power in an AC Circuit

Ideal capacitors and inductors store energy, but don't lose or dissipate it. So they do not have a power output. Real capacitors and inductors will have some resistance in their parts. But for now we will assume this is small.

To find the average power loss in our LRC circuit, we will take

$$\mathcal{P}_{ave} = I_{rms}^2 R \quad (37.28)$$

which is great because we can measure  $I_{rms}$  directly from our AC ammeter. Remember we also had a DC power equation that had potential drop in it. We got it by using Ohm's law

$$\Delta V_{R,rms} = I_{rms} R$$

or

$$R = \frac{\Delta V_{R,rms}}{\Delta I_{rms}}$$

then

$$\mathcal{P}_{ave} = I_{rms}^2 \frac{\Delta V_R}{\Delta I_{rms}} \quad (37.29)$$

$$= I_{rms} \Delta V_R \quad (37.30)$$

We will write this equation in a funny way.

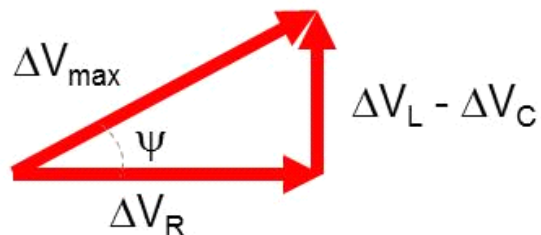

In our diagram, we see that  $\Delta V_R$  is just the  $x$ -component of  $\Delta V_{\max}$ . This is true for our rms voltage as well (same triangle) so we can write

$$\Delta V_{R_{rms}} = \Delta V_{rms} \cos \psi \quad (37.31)$$

then

$$\mathcal{P}_{ave} = I_{rms} \Delta V_{R_{rms}} \cos \psi \quad (37.32)$$

if you work with AC circuits you might find  $\cos \psi$  called the *power factor*.

Note that I did not define the instantaneous power. We can certainly do that

$$\begin{aligned} \mathcal{P}_{inst} &= i\Delta v = I_{\max} \cos(\omega t - \psi) \Delta V_{\max} \cos \omega t \\ &= I_{\max} \Delta V_{\max} \cos(\omega t - \psi) \cos \omega t \end{aligned} \quad (37.33)$$

which is messy. With a trig identity,

$$\cos(\omega t - \psi) = \cos \omega t \cos \psi + \sin \omega t \sin \psi$$

we can show that this is

$$\mathcal{P}_{inst} = I_{\max} \Delta V_{\max} (\cos \omega t \cos \psi + \sin \omega t \sin \psi) \cos \omega t$$

$$\mathcal{P}_{inst} = I_{\max} \Delta V_{\max} \cos^2(\omega t) \cos \psi - I_{\max} \Delta V_{\max} \sin \omega t \cos \omega t \sin \psi$$

But we often are not able to view this because it changes so rapidly. Our meters usually only take a time average.

$$\begin{aligned} \bar{\mathcal{P}} &= \int_{\text{many T}} I_{\max} \Delta V_{\max} \cos^2(\omega t) \cos \psi dt - \int_{\text{many T}} I_{\max} \Delta V_{\max} \sin \omega t \cos \omega t \sin \psi dt \\ &= \frac{1}{2} I_{\max} \Delta V_{\max} \cos \psi - 0 \end{aligned}$$

or just

$$\bar{\mathcal{P}} = \frac{1}{2} I_{\max} \Delta V_{\max} \cos \psi + 0 \quad (37.34)$$

This is what a power meter would see.

**Question 33.13**

## Power for an LRC circuit

Now that we know about power in AC circuits, let's look at the power in an LRC circuit as a function of  $\omega$ . We just found that

$$\begin{aligned} \mathcal{P}_{ave} &= I_{rms}^2 R \\ &= \frac{\Delta V_{rms}^2 R}{(R)^2 + \frac{L^2}{\omega^2} (\omega^2 - \omega_o^2)^2} \end{aligned} \quad (37.35)$$

It is convenient to rewrite this as

$$\mathcal{P}_{ave} = \frac{\Delta V_{rms}^2 R \omega^2}{\omega^2 R^2 + L^2 (\omega^2 - \omega_o^2)^2}$$

If we plot the same values for the components in our LRC circuit,

$$\begin{aligned} L &= 50 \times 10^{-6} \text{ H} \\ C &= 2.0 \times 10^{-9} \text{ F} \\ \Delta V_{rms} &= 5 \times 10^{-3} \text{ V} \\ \omega_o &= 1 \times 10^7 \frac{\text{rad}}{\text{s}} \end{aligned}$$

we find that the power looks like this

$$\mathcal{P}_{ave} = \frac{(5 \times 10^{-3} \text{ V}) R \omega^2}{\omega^2 R^2 + (5.0 \times 10^{-6} \text{ H})^2 (\omega^2 - (1 \times 10^7 \frac{\text{rad}}{\text{s}})^2)^2}$$

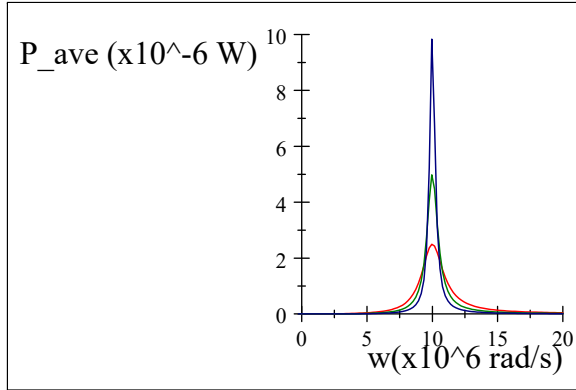

Note that the width of the power curve changes as a function of the resistance. The “sharpness” of the curve is described by the *quality factor*

$$Q = \frac{\omega_o}{\Delta\omega} \tag{37.36}$$

This is often just called the “Q” of the curve. The  $\Delta\omega$  is measured at the half power points. We can find them

$$\begin{aligned} \frac{\mathcal{P}_{peak}}{2} &= \frac{\frac{1}{2} \Delta V_{rms}^2 R \omega_o^2}{\omega_o^2 R^2 + L^2 (\omega_o^2 - \omega_o^2)^2} \\ &= \frac{\Delta V_{rms}^2}{2R} \end{aligned} \tag{37.37}$$

so we find  $\omega$  when

$$\frac{\Delta V_{rms}^2}{2R} = \frac{\Delta V_{rms}^2 R \omega^2}{\omega^2 R^2 + L^2 (\omega^2 - \omega_o^2)^2} \tag{37.38}$$

$$\frac{1}{2R^2} = \frac{\omega^2}{\omega^2 R^2 + L^2 (\omega^2 - \omega_o^2)^2} \tag{37.39}$$

$$\frac{1}{2R^2} (\omega^2 R^2 + L^2 (\omega^2 - \omega_o^2)^2) = \omega^2 \tag{37.40}$$

$$\omega^2 R^2 \frac{1}{2R^2} + \frac{1}{2R^2} L^2 (\omega^2 - \omega_o^2)^2 = \omega^2 \tag{37.41}$$

$$\frac{\omega^2}{2} + \frac{L^2}{2R^2} (\omega^4 - 2\omega^2\omega_o^2 + \omega_o^4) = \omega^2 \quad (37.42)$$

$$-\frac{\omega^2}{2} + \frac{L^2}{2R^2} (\omega^4 - 2\omega^2\omega_o^2 + \omega_o^4) = 0 \quad (37.43)$$

$$-\omega^2 + \frac{L^2}{R^2} (\omega^4 - 2\omega^2\omega_o^2 + \omega_o^4) = 0 \quad (37.44)$$

$$-\omega^2 + \frac{L^2}{R^2}\omega^4 - 2\frac{L^2}{R^2}\omega^2\omega_o^2 + \frac{L^2}{R^2}\omega_o^4 = 0 \quad (37.45)$$

$$\frac{L^2}{R^2}\omega^4 - \omega^2 \left( 2\frac{L^2}{R^2}\omega_o^2 + 1 \right) + \frac{L^2}{R^2}\omega_o^4 = 0 \quad (37.46)$$

There are four solutions,

$$\omega_1 = -\frac{1}{2L} \left( R - \sqrt{4L^2\omega_o^2 + R^2} \right) \quad (37.47)$$

$$\omega_2 = \frac{1}{2L} \left( R - \sqrt{4L^2\omega_o^2 + R^2} \right) \quad (37.48)$$

$$\omega_3 = -\frac{1}{2L} \left( R + \sqrt{4L^2\omega_o^2 + R^2} \right) \quad (37.49)$$

$$\omega_4 = \frac{1}{2L} \left( R + \sqrt{4L^2\omega_o^2 + R^2} \right) \quad (37.50)$$

We can see where these lie on our graph of  $\mathcal{P}_{ave}$

$$\omega_1 = -\frac{\left( 10 \Omega - \sqrt{4(50 \times 10^{-6} \text{ H})^2 (1 \times 10^7 \frac{\text{rad}}{\text{s}})^2 + (10 \Omega)^2} \right)}{2(50 \times 10^{-6} \text{ H})} = 9900499.99 \frac{\text{rad}}{\text{s}} \quad (37.51)$$

$$\omega_2 = \frac{\left( 10 \Omega - \sqrt{4(50 \times 10^{-6} \text{ H})^2 (1 \times 10^7 \frac{\text{rad}}{\text{s}})^2 + (10 \Omega)^2} \right)}{2(50 \times 10^{-6} \text{ H})} = -9900499.99 \frac{\text{rad}}{\text{s}} \quad (37.52)$$

$$\omega_3 = -\frac{\left( 10 \Omega + \sqrt{4(50 \times 10^{-6} \text{ H})^2 (1 \times 10^7 \frac{\text{rad}}{\text{s}})^2 + (10 \Omega)^2} \right)}{2(50 \times 10^{-6} \text{ H})} = -10100500.01 \frac{\text{rad}}{\text{s}} \quad (37.53)$$

$$\omega_4 = \frac{\left( 10 \Omega + \sqrt{4(50 \times 10^{-6} \text{ H})^2 (1 \times 10^7 \frac{\text{rad}}{\text{s}})^2 + (10 \Omega)^2} \right)}{2(50 \times 10^{-6} \text{ H})} = 10100500.01 \frac{\text{rad}}{\text{s}} \quad (37.54)$$

Two of which are negative, so we will ignore them. The other two are centered around

$\omega_o = 1 \times 10^7 \frac{\text{rad}}{\text{s}}$  as we would expect. If we find the difference between the two

$$\Delta\omega = \omega_4 - \omega_1 \quad (37.55)$$

$$= \frac{1}{2L} \left( R + \sqrt{4L^2\omega_o^2 + R^2} \right) - \left( -\frac{1}{2L} \left( R - \sqrt{4L^2\omega_o^2 + R^2} \right) \right) \quad (37.56)$$

$$= \frac{1}{2L} R - \frac{1}{2L} \sqrt{4L^2\omega_o^2 + R^2} - \left( -\frac{1}{2L} R - \frac{1}{2L} \sqrt{4L^2\omega_o^2 + R^2} \right) \quad (37.57)$$

$$= \frac{1}{2L} R - \frac{1}{2L} \sqrt{4L^2\omega_o^2 + R^2} + \frac{1}{2L} R + \frac{1}{2L} \sqrt{4L^2\omega_o^2 + R^2} \quad (37.58)$$

$$= \frac{R}{L} \quad (37.59)$$

Now let's remember why we started this long mathematical mess. We wanted to know the "Q-factor" for our LRC power curve. Since

$$Q = \frac{\omega_o}{\Delta\omega}$$

then

$$Q = \frac{\omega_o L}{R}$$

For a radio, we want to adjust the resistance to be high and the inductance to be low enough that only one radio station frequency can be heard at a time. Because of this, the LRC circuit in a radio tuner is usually tuned by changing the capacitance.

## Retrospective

We have thought about many things in this class. It has been a class *about* science. It has not been a class where we have tried to discover new science, or practiced the scientific method. This is on purpose, this being an engineering class designed to teach the principles of physics for use in designing machines.

But we should pause to think, just for a moment, about the philosophy of science. Is everything in these lectures true? We did not perform experiments to show every principle we learned. So does it all work?

The answer is—maybe. Experiments have been done to show that the equations we have learned work at least sometimes. But science is an inductive process. We can't prove anything true with science. We can only prove things false. So what we have studied is what has not been proven false, yet. Of course, even then, we have taken approximations from time to time, but we pointed these out along the way. You will know when the approximations will fail, because we talked about their valid ranges.

It is important to remember that we are not done discovering new things, and proving

old things false. The laws of Newton are approximations that work at low speeds. Relativity provides mechanical equations for very high speeds (e.g. the satellite motion involved in the GPS system). But is Relativity correct? We think it works pretty well, but really we don't know. We may never know for sure. But we know it works within the range of things we have tried.

There are physicists today that are working on a fundamentally new model of the universe. It is called "String Theory" and it would replace most of our thoughts about how matter is made and how it interacts. The equations would reduce to the ones we used in class for the conditions we considered. That is because the new equations have to match the results of the experiments that we have already done or they can't be correct. But the explanations might be very different.

Often, it is in using physics to build something that we learn about the limitations of physical theory. You may be part of that process. It is a happy process because extending our understanding allows us to build new things. But don't be surprised if some of the things we learned in this class are different by the time your children take their engineering physics course. That is what we should expect of an inductive process.

It is also important to note that revealed truth is not an inductive process. It is still not static (see article of faith 9), but it *can* prove something true as well as prove things false. I hope your FDSCI 101 experience gave you some insight into doing science as well as learning about science.

Some members view science and revelation as in opposition. But I think they are complementary. The scientific process allows us to eliminate things that are not true, allowing us to follow D&C 9:8 in preparation for seeking revelation. During a recent convocation speech, Elder Scott described using this process as a nuclear engineer during his engineering career . We can use this combination in our personal lives as well. I hope you will consider this in your careers and lives.

I have tried to give at least equal time to conceptual understanding and mathematical solving. I hope you review and refresh the conceptual understanding of the physics of what you build. Most of my industrial career, we built what we designed very well. We always did our calculations well. But we did, at times, build the wrong thing because the conceptual basis of the design was wrong. Such mistakes are difficult to fix. Conceptual understanding is a guiding principle for a successful design career. I hope this class has contributed to that conceptual understanding.



# Summary of Right Hand Rules

## PH121 or Dynamics Right Hand Rules

We had two right hand rules on PH121 We didn't give them numbers back then, so we will do that now.

### Right hand rule #0:

We found that angular velocity had a direction that was given by imagining you grab the axis of rotation with your right hand so that your fingers seem to curl the same way the object is rotating. Then your thumb gives the direction of  $\vec{\omega}$

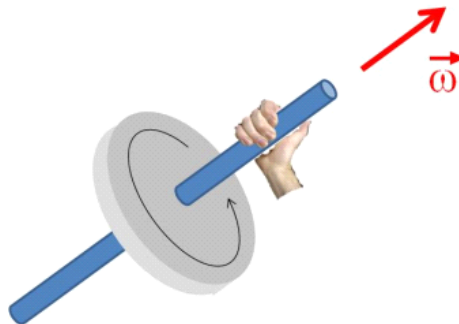

You curl the fingers of your right hand (sorry left handed people, you have to use your right hand for this) in the direction of rotation. Then your thumb points in the direction of the vector.

### Right hand rule #0.5:

To find the direction of torque, we used the following procedure

1. Put your fingers of your right hand in the direction of  $\vec{r}$

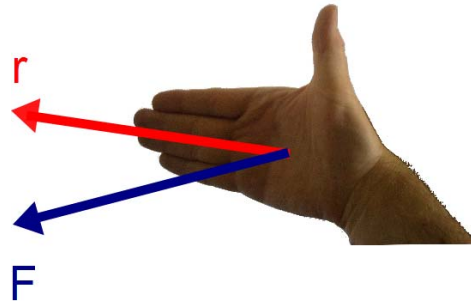

2. Curl them toward  $\vec{F}$

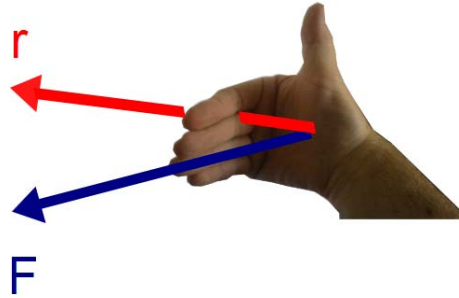

3. The direction of your thumb is the torque direction

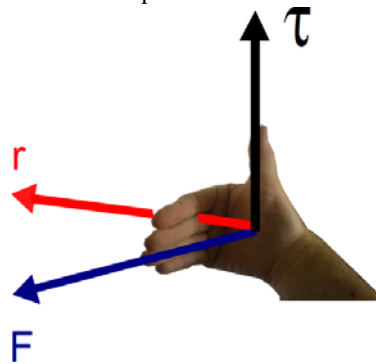

4. The angle  $\theta$  is the angle *between*  $\vec{r}$  and  $\vec{F}$

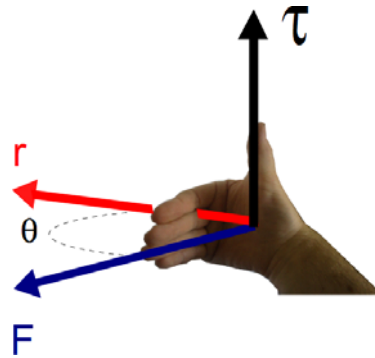

The magnitude of the torque is

$$\tau = rF \sin \theta$$

## PH223 Right Hand Rules

We have four more right hand rules this semester having to do with charges and fields.

### Right hand rule #1:

From this rule we get the **direction of the force on a moving charged particle** as it travels through a **magnetic field**.

This rule is very like torque. We start with our hand pointing in the direction of  $\vec{v}$ . Curl your fingers in the direction of  $\vec{B}$ . And your thumb will point in the direction of the force. The magnitude of the force is given by

$$F = qvB \sin \theta \quad (37.60)$$

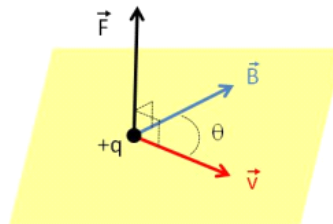

## Right hand rule #2:

From this rule we get the direction of the force on current carrying wire that is in a magnetic field.

This rule is very like right hand rule #1 above. We start with our hand pointing in the direction of  $\mathbf{I}$ . Curl your fingers in the direction of  $\tilde{\mathbf{B}}$ . And your thumb will point in the direction of the force. The magnitude of the force is given by

$$F = ILB \sin \theta \quad (37.61)$$

## Right hand rule #3:

From this rule we get the **direction of the magnetic field that surrounds a long current carrying wire.**

This rule is quite different. It is reminiscent of the rule for angular velocity, but there are some major differences as well. The field is a magnitude and a direction at every point in space. We can envision drawing surfaces of constant field strength. They will form concentric circles (really cylinders) centered on the wire. At any one point on the circle the field direction will be along a tangent to the circle. The direction of the vector is given by imaging you grab the wire with your right hand (don't really do it). Grab such that your right thumb is in the direction of the current. Your fingers will naturally curl in the direction of the field.

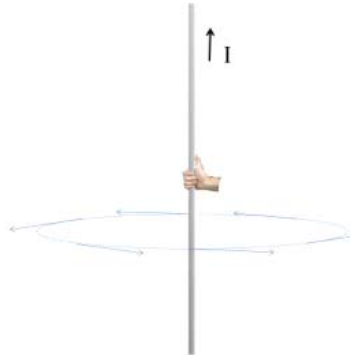

## Right Hand Rule #4:

From this rule we get the **direction of the induced current when a loop is in a**

### changing magnetic field.

This rule is only used when we have a loop with a changing external magnetic field. The rule gives the direction of the induced current. The induced magnetic field will oppose the change in the external field, trying to prevent a change in the flux. The current direction is found by imagining we stick our right hand into the loop in the direction of the induced field. Keeping our hand inside the loop we grab a side of the loop. The current goes in the direction indicated by our thumb.

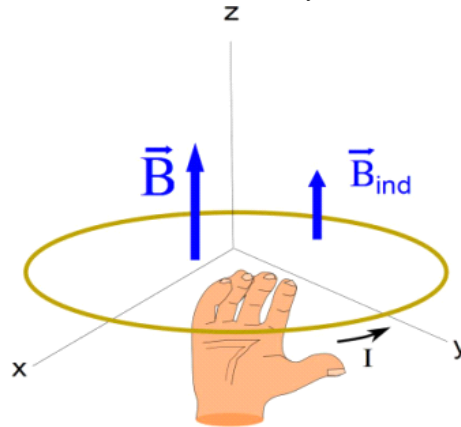

In the figure above, the external field is upward but decreasing. So the induced field is upward. The current flows because there is an induced *emf* given by

$$\begin{aligned}\mathcal{E} &= -N \frac{\Delta\Phi}{\Delta t} \\ &= -N \frac{(B_2 A_2 \cos \theta_2 - B_1 A_1 \cos \theta_1)}{\Delta t}\end{aligned}$$



# Integral Table

## Some Helpful Integrals

$$\int \frac{r dr}{\sqrt{r^2 + x^2}} = \sqrt{r^2 + x^2}$$

$$\int \frac{dx}{(x^2 \pm a^2)^{\frac{3}{2}}} = \frac{\pm x}{a^2 \sqrt{x^2 \pm a^2}}$$

$$\int \frac{xdx}{(x^2 \pm a^2)^{\frac{3}{2}}} = \frac{-1}{\sqrt{x^2 \pm a^2}}$$

$$\int \frac{dx}{x} = \ln x$$

$$\int \frac{dx}{x^2} = -\frac{1}{x}$$

$$\int_0^{2\pi} \int_0^{\pi} \int_0^R \sin \theta d\theta d\phi = 4\pi$$

$$\int_0^{2\pi} \int_0^{\pi} \int_0^R r^2 dr \sin \theta d\theta d\phi = \frac{4}{3}\pi R^3$$

$$\int_0^{2\pi} \int_0^R r dr d\phi = \pi R^2$$





# Table of Physical Constants

## Charge and mass of elementary particles

Proton Mass	$m_p = 1.6726231 \times 10^{-27} \text{ kg}$
Neutron Mass	$m_n = 1.6749286 \times 10^{-27} \text{ kg}$
Electron Mass	$m_e = 9.1093897 \times 10^{-31} \text{ kg}$
Electron Charge	$q_e = -1.60217733 \times 10^{-19} \text{ C}$
Proton Charge	$q_p = 1.60217733 \times 10^{-19} \text{ C}$

$\alpha$ -particle mass <sup>26</sup>	$m_\alpha = 6.64465675(29) \times 10^{-27} \text{ kg}$
$\alpha$ -particle charge	$q_\alpha = 2q_e$

## Fundamental constants

Permittivity of free space	$\epsilon_o = 8.854187817 \times 10^{-12} \frac{\text{C}^2}{\text{Nm}^2}$
Permiability of free space	$\mu_o = 4\pi \times 10^{-7} \frac{\text{Tm}}{\text{A}}$
Colomb Constant	$K = \frac{1}{4\pi\epsilon_o} = 8.98755 \times 10^9 \text{ Nm}^2 \text{ C}^{-2}$
Gravitational Constant	$G = 6.67259 \times 10^{-11} \text{ m}^3 \text{ kg}^{-1} \text{ s}^{-2}$
Speed of light	$c = 2.99792458 \times 10^8 \text{ m s}^{-1}$
Avagadro's Number	$6.0221367 \times 10^{23} \text{ mol}^{-1}$
Fundamental unit of charge	$q_f = 1.60217733 \times 10^{-19} \text{ C}$

## Astronomical numbers

Mass of the Earth <sup>27</sup>	$5.9726 \times 10^{24} \text{ kg}$
Mass of the Moon <sup>28</sup>	$0.07342 \times 10^{24} \text{ kg}$
Earth-Moon distance (mean) <sup>29</sup>	384400 km
Mass of the Sun <sup>30</sup>	$1,988,500 \times 10^{24} \text{ kg}$
Earth-Sun distance <sup>31</sup>	$149.6 \times 10^6 \text{ km}$

## Condtivity and resistivity of various metals

<sup>26</sup> <http://physics.nist.gov/cgi-bin/cuu/Value?mal>

<sup>27</sup> <http://nssdc.gsfc.nasa.gov/planetary/factsheet/earthfact.html>

<sup>28</sup> <http://nssdc.gsfc.nasa.gov/planetary/factsheet/moonfact.html>

<sup>29</sup> <http://solarsystem.nasa.gov/planets/profile.cfm?Display=Facts&Object=Moon>

<sup>30</sup> <http://nssdc.gsfc.nasa.gov/planetary/factsheet/sunfact.html>

<sup>31</sup> <http://nssdc.gsfc.nasa.gov/planetary/factsheet/index.html>

Material	Conductivity ( $\Omega^{-1} \text{ m}^{-1}$ )	Resistivity ( $\Omega \text{ m}$ )	Temp. Coeff. ( $\text{K}^{-1}$ )
Aluminum	$3.5 \times 10^7$	$2.8 \times 10^{-8}$	$3.9 \times 10^{-3}$
Copper	$6.0 \times 10^7$	$1.7 \times 10^{-8}$	$3.9 \times 10^{-3}$
Gold	$4.1 \times 10^7$	$2.4 \times 10^{-8}$	$3.4 \times 10^{-3}$
Iron	$1.0 \times 10^7$	$9.7 \times 10^{-8}$	$5.0 \times 10^{-3}$
Silver	$6.2 \times 10^7$	$1.6 \times 10^{-8}$	$3.8 \times 10^{-3}$
Tungsten	$1.8 \times 10^7$	$5.6 \times 10^{-8}$	$4.5 \times 10^{-3}$
Nichrome	$6.7 \times 10^5$	$1.5 \times 10^{-6}$	$0.4 \times 10^{-3}$
Carbon	$2.9 \times 10^4$	$3.5 \times 10^{-5}$	$-0.5 \times 10^{-3}$